

No.	Designation	Identification	No. of pages
1	Alarm list	5735-00	1
2	Electrical Adjustments	5736-00	30
3	Power and control supply	48.00059430-00	13
4	Parts list	48.00059430-00	3
5	Wiring top crane	48.00059431-00	1
6	Parts list	48.00059431-00	1
7	Parts list – Drivers cabin	48.00059432	1
8	Faults and alarms	Sinamics	259

## ALARM LIST

<u>Mes. No.</u>	<u>Cause</u>
2001	Erection condition selected, overload equipment cut out
2002	Phase fault or under voltage alarm from relay U6
2003	Height override button has been activated before erection key set ON
2004	Joysticks not in neutral position when starting up
2005	Moment 110% safety switch from mechanical moment switch
2006	Overload 110% safety switch from U12
2007	Q4 circuit breaker for heater has tripped
2008	Q5 circuit breaker for power has tripped
2009	Q6 circuit breaker for power has tripped
2010	Motor temperature alarm from hoist motor
2011	Q13 circuit breaker for hoist brake has tripped
2012	Q8 circuit breaker for power has tripped
2013	Q15 circuit breaker for motor heaters has tripped
2015	Fault from hoist inverter U1
2016	Hoist over speed alarm from relay U10
2017	Ultimate hoist limit activated, crane emergency stopped
2018	Hoist position reference not ready, stop and start the crane
2020	Motor temperature alarm from slew motor
2021	Q23 circuit breaker for slewing brake has tripped
2022	Q21.1, Q21.2 or Q21.3 circuit breaker for slew motors has tripped
2025	Fault from slew inverter U2
2026	Fault from Right-hand joystick. Function is stopped
2027	Fault from Left-hand joystick. Function is stopped
2030	Motor temperature alarm from trolley motor
2031	Q33 circuit breaker for motor trolley brake has tripped
2035	Fault from trolley inverter U3
2038	Trolley position reference not ready, stop and start the crane
2042	Fault from Active Line Module U111
2043	Fault from CU320 controller U108
2044	Communication error with CU320 controller U108
2045	Communication error with Active Line Module U111
2046	Communication error with hoist inverter U1
2047	Communication error with slew inverter U2
2048	Communication error with luff inverter U3
2050	Negative signal from load cell
2051	103 % SWL, OVERLOAD
2054	Depth limit setting too close to height limit ay hook height setting
2055	Max. load setting out of range
2056	Max trolley radius too close to min radius at radius setting
2060	Erection key is ON, over speed & ultimate limits in override mode

# **ELECTRICAL ADJUSTMENTS**

## **CONTENTS**

Page

Electrical connections.....	2
Start up the crane .....	2
Erection condition .....	3
Trolley radius and limit setting .....	6
Minimum trolley radius .....	7
Maximum trolley radius.....	8
Hoist limit settings.....	9
Hook height limit .....	10
Hoist depth limit.....	11
Wire part selection.....	12
Load/Moment settings .....	13
Load settings .....	14
Hoist zero load setting .....	15
Hoist maximum load setting .....	16
Moment .....	17
110% overload .....	17
Slew encoder deactivation/activation .....	18
Slew limits .....	19
Slew limit settings.....	20
Zone setting.....	21
Service .....	23
Alarm/event buffer .....	24
Hour counters .....	24
Joystick signals .....	25
Wind speed configuration .....	26
Set time & date.....	26
Display brightness.....	27
Flood light switch.....	27
Max. speed .....	28
Data Logging .....	29

## **Electrical connections**

Make up all cable connections according to the cranes wiring diagram  
Switch on the power and check the lamp comes ON, on phase fault relay U6, if not change two phases on the incoming power supply.

## **Start up the crane**

Start up the crane by releasing the Emergency stop button, turn the key switch and press the start button on the right hand control box.

NOTE: When switching OFF the crane use the key switch and **not** the emergency stop stop.

Engage relay D1A, safety relay D1 and main contactor C1 should now switch ON in the electrical panel.

In case the engage relay D1A does not activate, check the emergency stop button, the key switch, all joysticks are in neutral position, no overspeed alarm and phase fault relay U6 is lit green.

In case the safety relay D1 does not activate, check the emergency stop button, over speed relays U10, ultimate limits. An alarm text in the operator's display will inform which function to check.

In case main contactor C1 does not activate, check for alarms in the operator display, check the RUN LED is green on PLC U101, check the READY LED is green on the motor drive unit U108 and all the infeed modules U110 & U111.

Check the operator display whether any alarms are active. After rectifying a fault reset the fault on the Reset button in the display or by restarting the crane.

## Erection condition

Before the overload equipment and the limit switches have been set the hoist and trolley motion might be stopped due to an active limit. Therefore during the initial setting of the overload equipment and limit switches all limits might have to be cut out by selecting Erection condition.

To select Erection condition:

- Press the change page button on the screen display

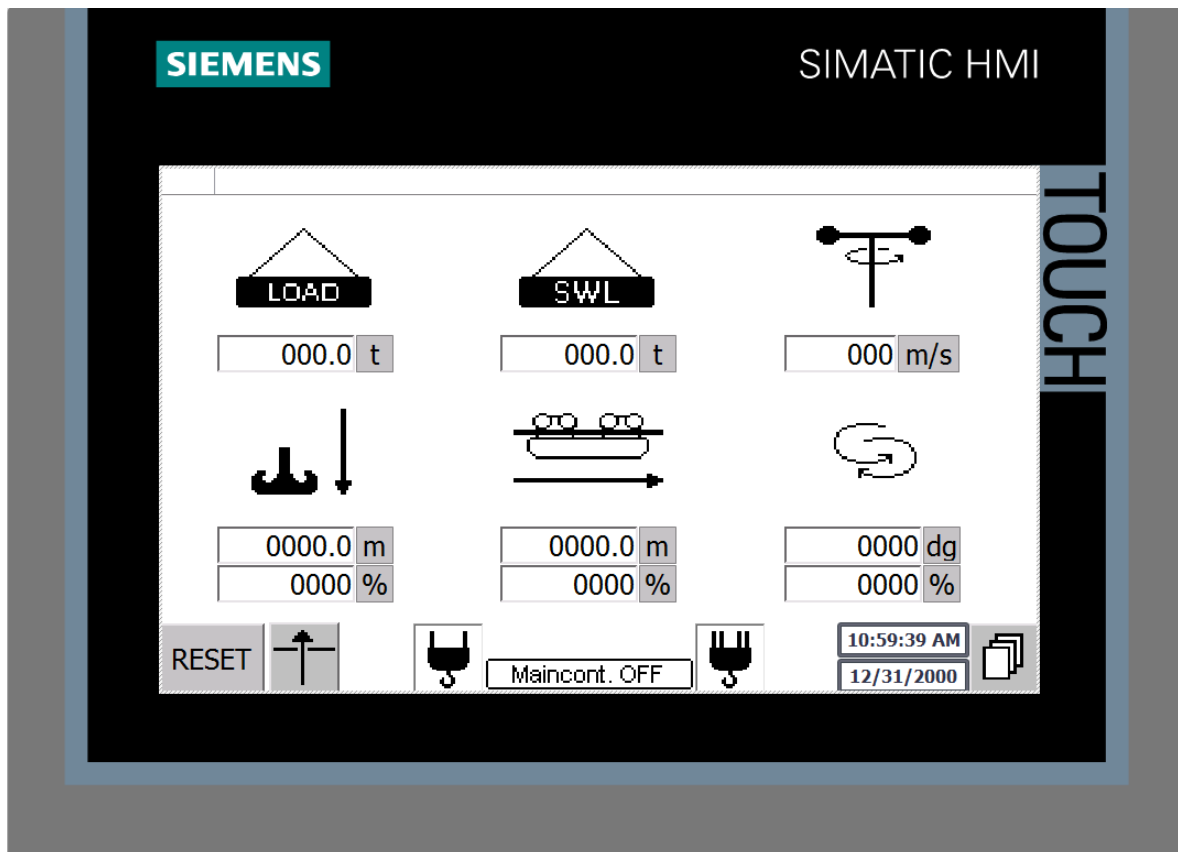

Status screen

- Press on the Settings button.

NOTE: The setting button will only be visible when the Erection key in the electrical panel is activated.

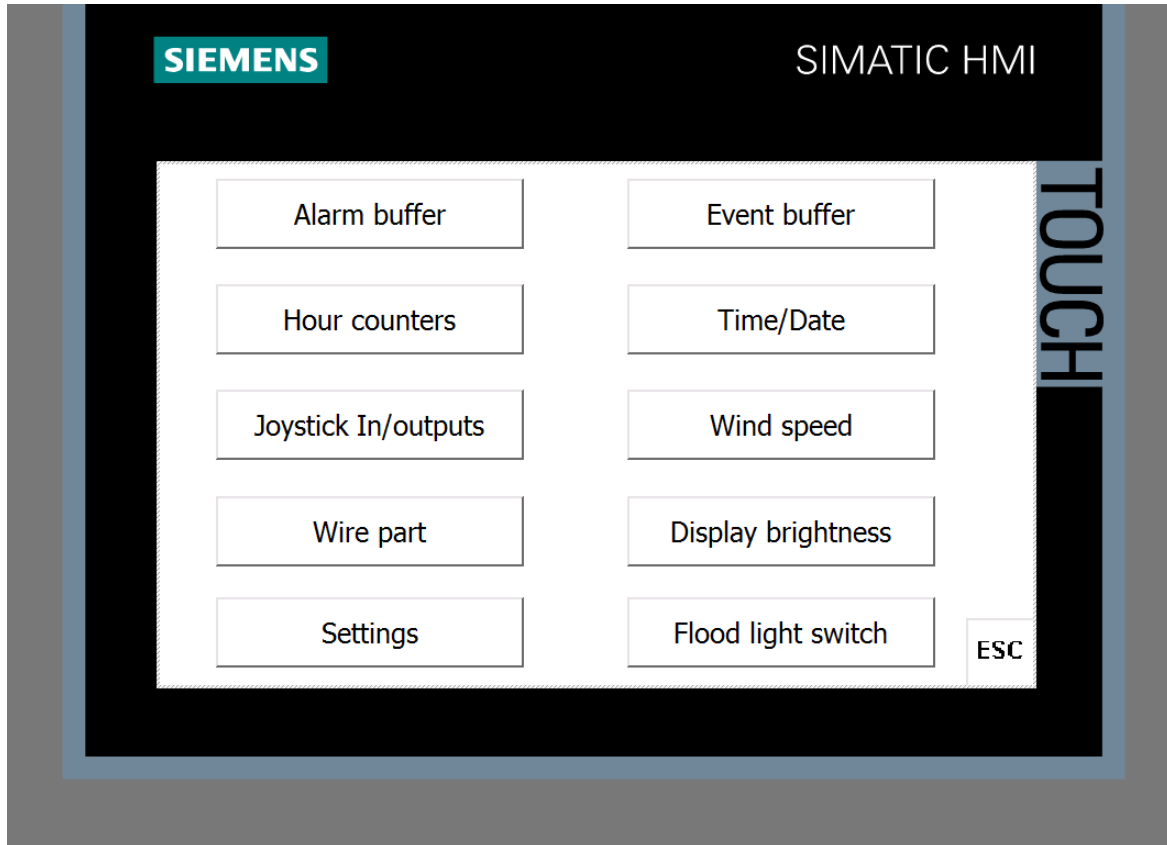

Select screen

The display screen will ask for a Username and Password:

- Press on the Username window and a keyboard will appear on the screen
- Enter Username: KROLL - ↵
- Press on the Password window and the keyboard will appear on the screen again
- Enter password: 7400 - ↵
- Press OK
- Now press the Settings button again
- A new page will appear on the screen, here press the Erection condition button

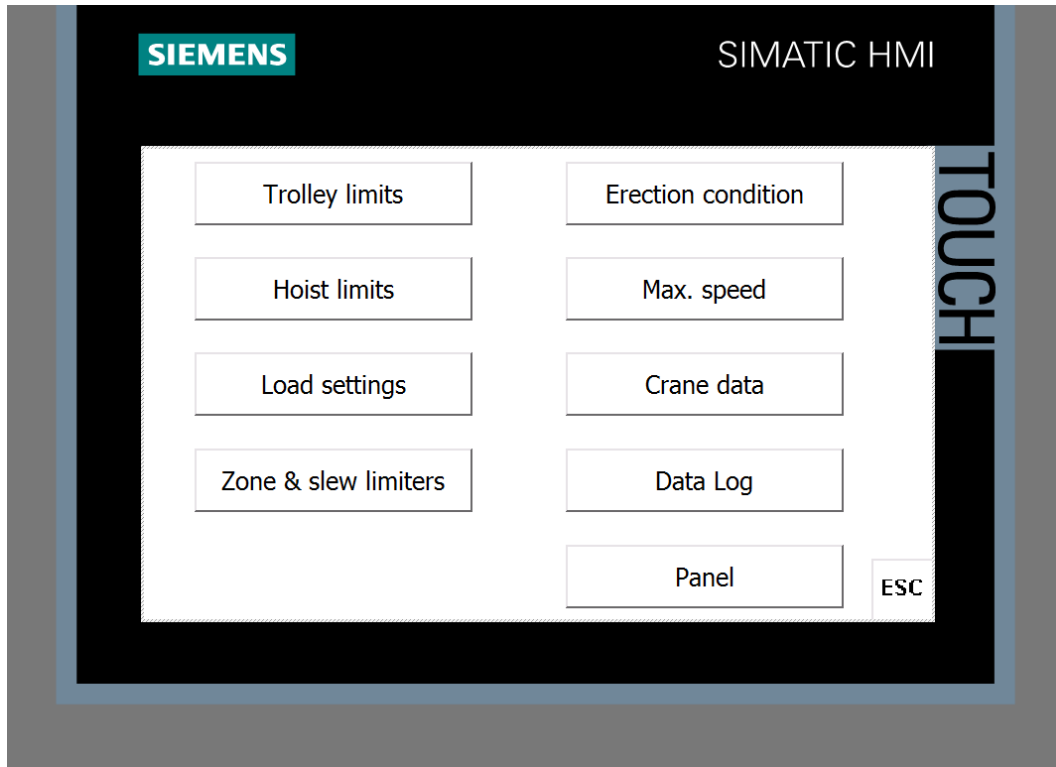

Setting screen

Press the OFF button to select Erection condition and the button will automatically change to ON

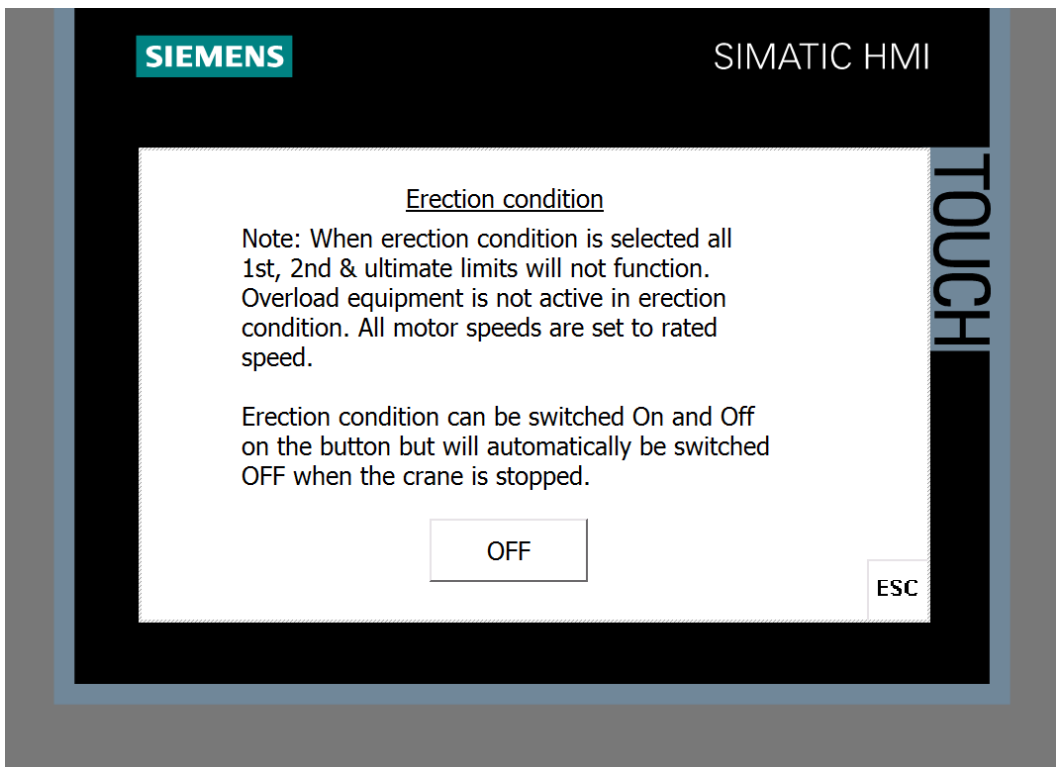

Erection condition screen

Now Erection condition is selected and the overload equipment and all limits are cut out.

## Trolley radius and limit setting

- To set the trolley radius indicator “Jib settings” button on the screen under the Setting menu

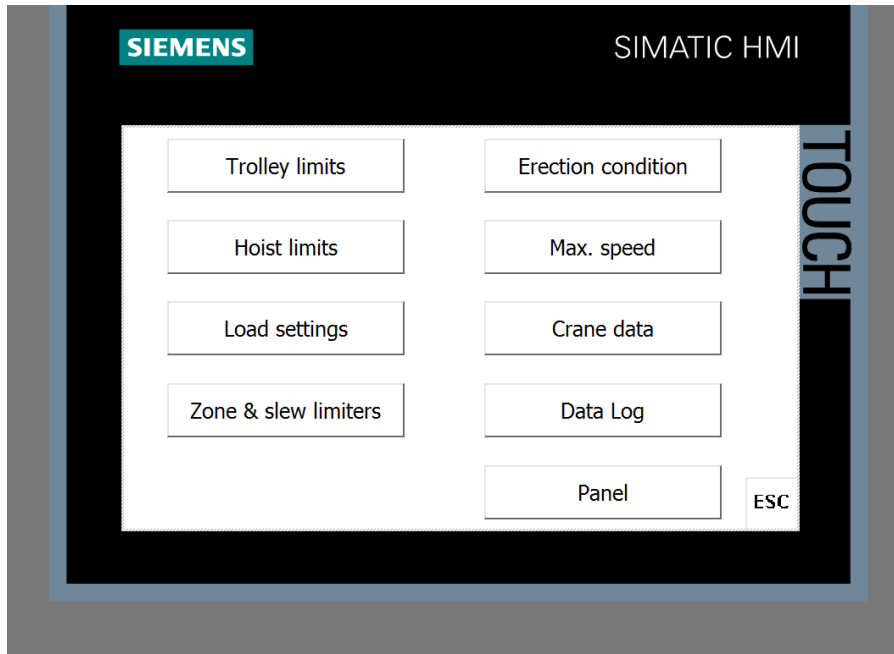

Setting screen

- Select erected jib length and press the “Next” button

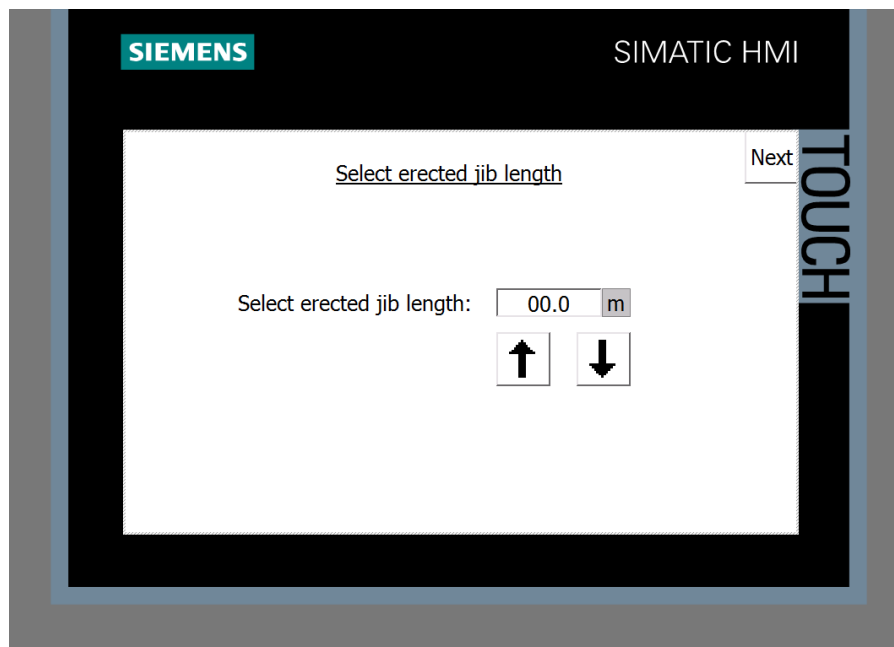

Jib selection screen

**Note:** The jib selection is very important. This function also selects the correct load diagram for the erected jib configuration.



## Minimum trolley radius

Set the radius indicator via the display.

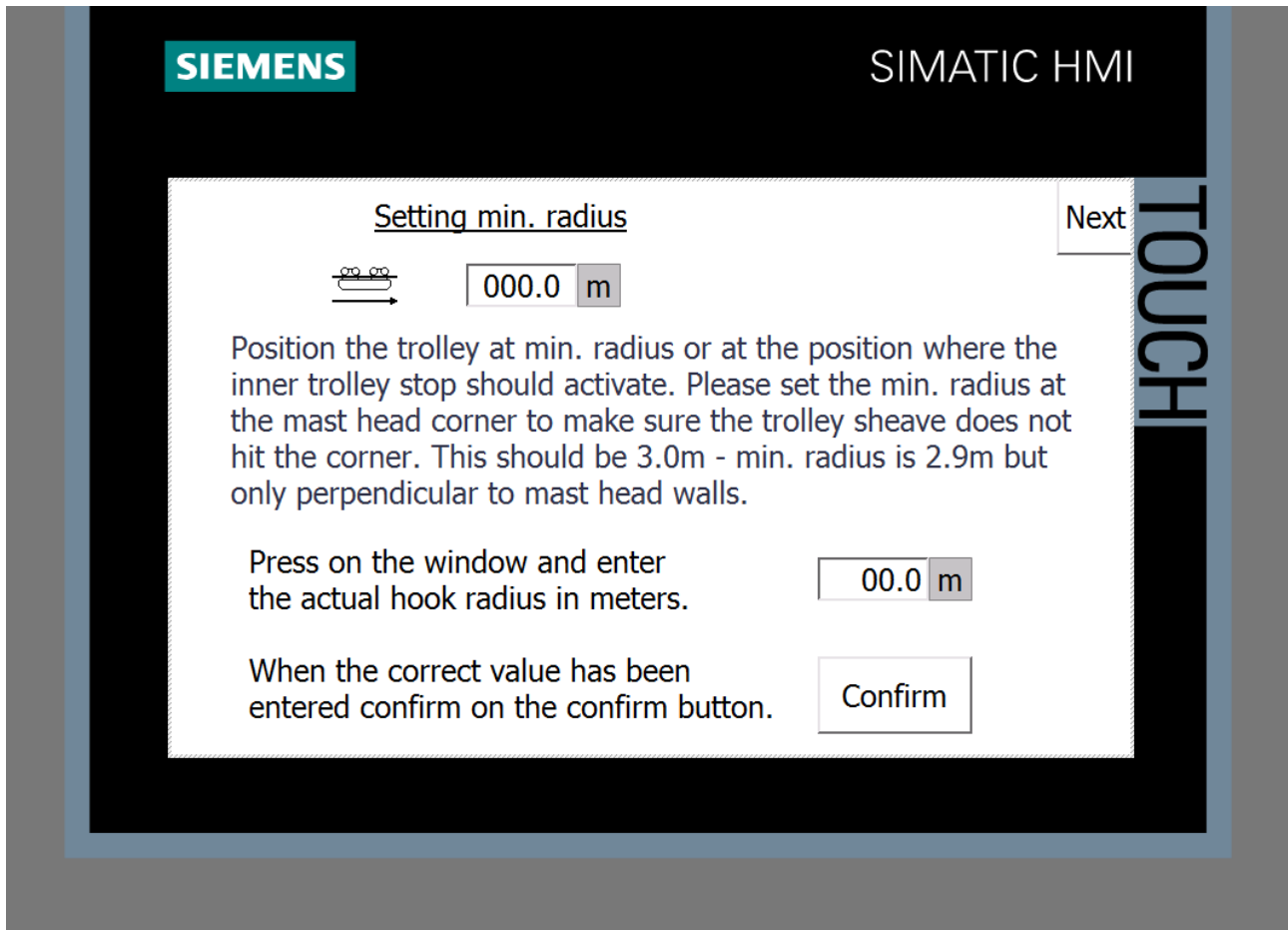

Minimum radius setting screen

- Park the trolley at minimum hook radius measured out, on the ground, from the centre of the mast to the hook
- Press on the radius indicator window and a keyboard appears on the screen. Type in the minimum radius of the hook.
- When the correct radius value has been entered press the "Confirm" button.
- Press the Next button and the screen for setting the maximum radius and outer trolley limit appears on the display

## Maximum trolley radius

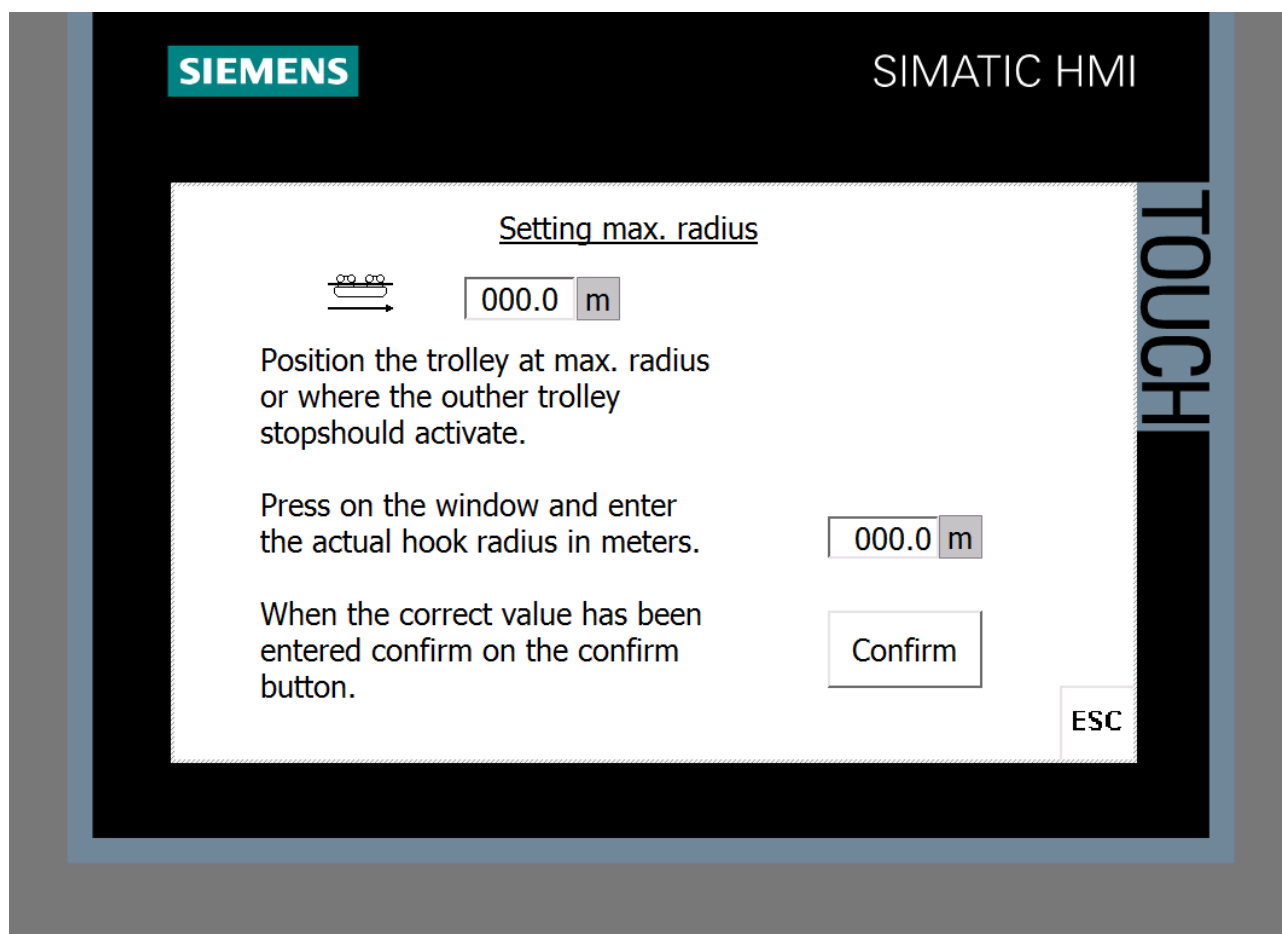

Maximum radius setting screen

- Park the trolley at the maximum hook radius.
- Press on the radius indicator window and a keyboard appears on the screen.
- Enter the actual max. radius value and press the “Confirm” button.
- Press the ESC button and the trolley radius is completed.

## Hoist limit settings

- First, set the mechanical ultimate hoist up limit. The cam limit switch is fitted on the hoist drum.
- With the hook parked approx. 1.0m from the jib and set the ultimate hoist up limit at this position.

Note: Erection condition will need to be selected in order to set the ultimate limits. If not the crane will emergency stop.

- To set the software hoist limit press the “Hoist limit” button on the screen under the Setting menu

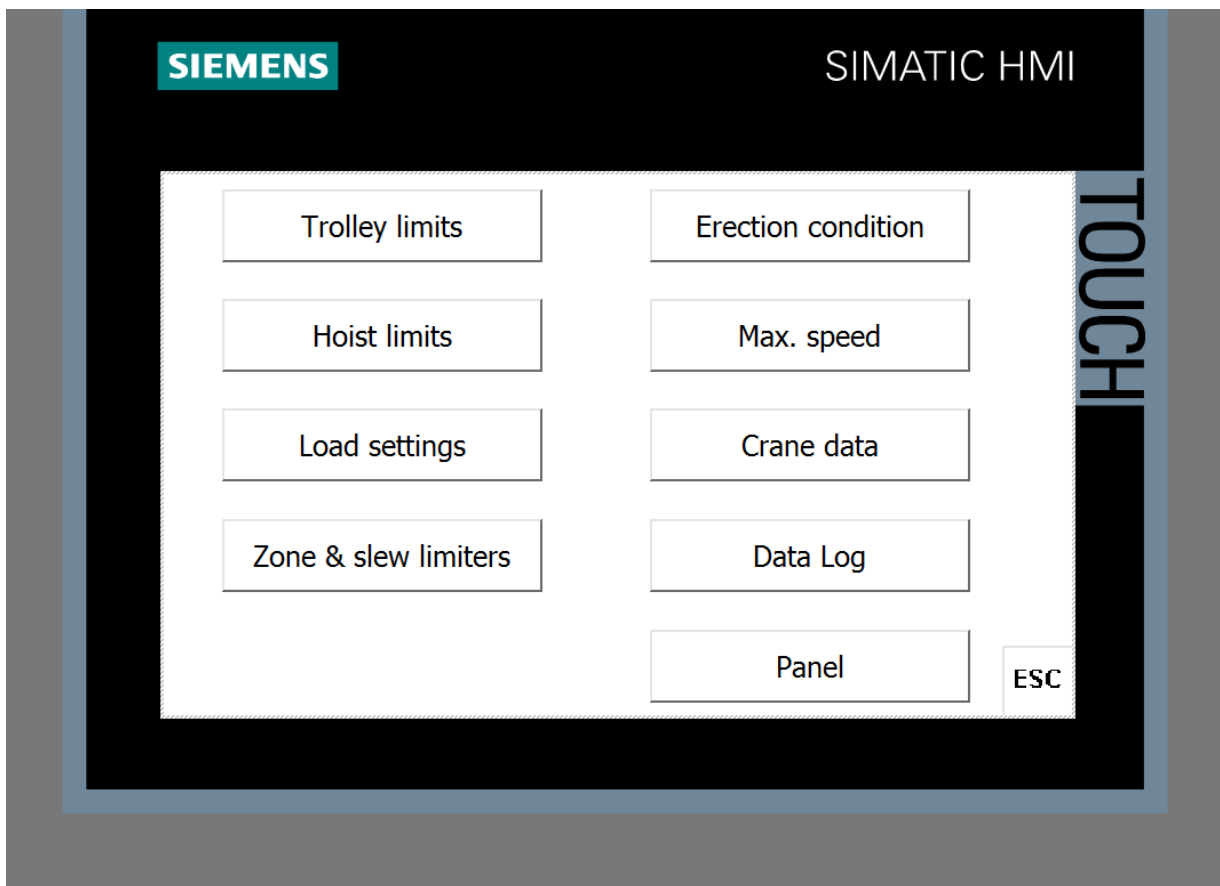

Setting screen

## Hook height limit

- Move the hook down, approx. 1.5m from the boom.
- Set the software height limit at this position by pressing the “Set stop” button in the display.
- The indicator window should now read “0.0”
- Now the 1st and 2nd height limit is set

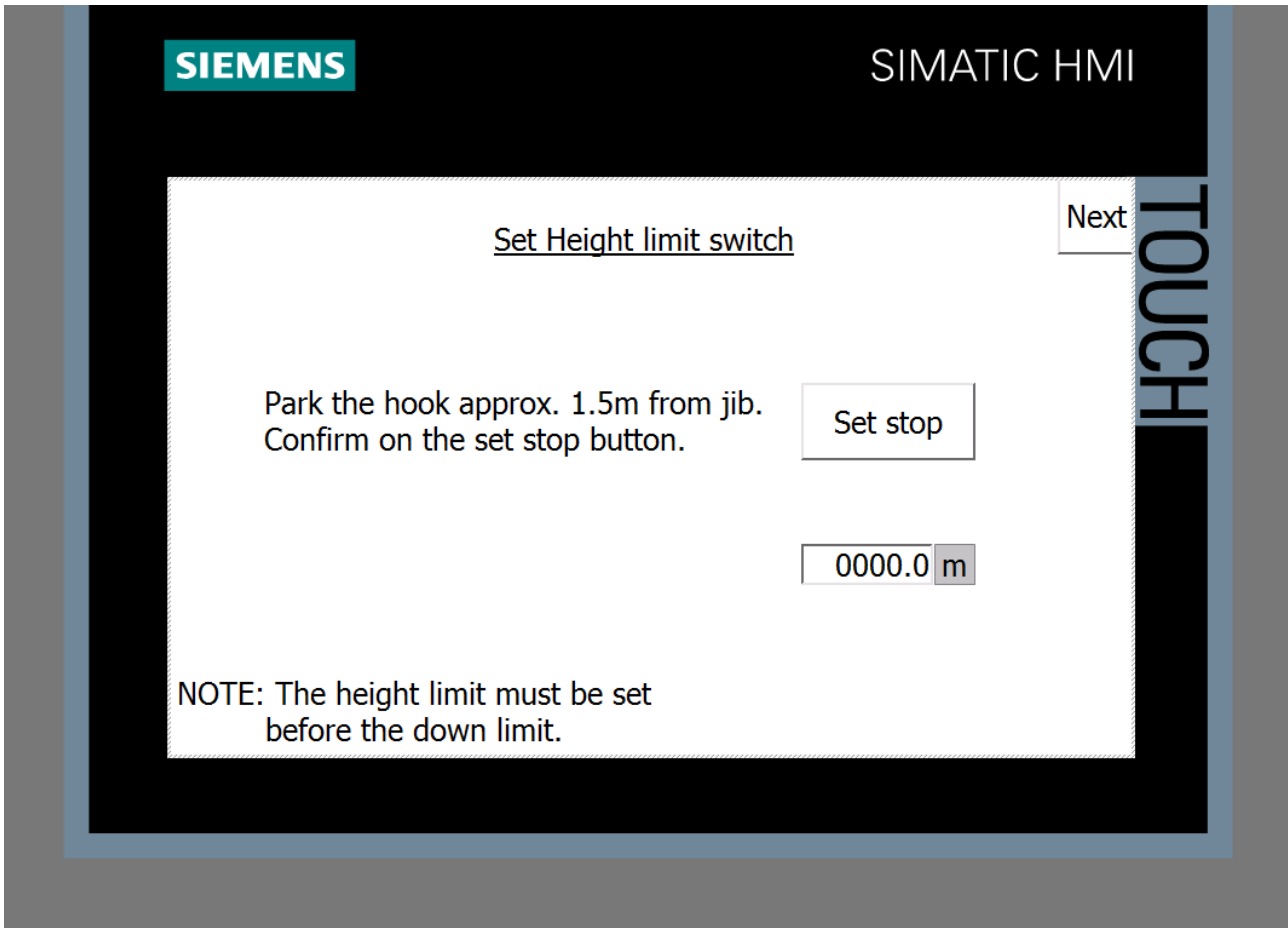

Height limit setting screen

- Press the Next button and the screen for setting the depth limit appears on the display

## Hoist depth limit

- The depth limit should be set with three turns left on the drum, to prevent the hoist rope from spooling off the drum. The depth limit can also be set as a working limit at the lowest point on the site – if at this position, there are three turns left on the drum.
- Park the main hook at the position where the depth limit is to be set. Press the “Set stop” button on the display.
- Now the 1st and 2nd depth limit is set
- Park the hook approx. 1m lower than the 2nd depth stop (can only be done in erection mode). Here adjust the ultimate limit down switch.

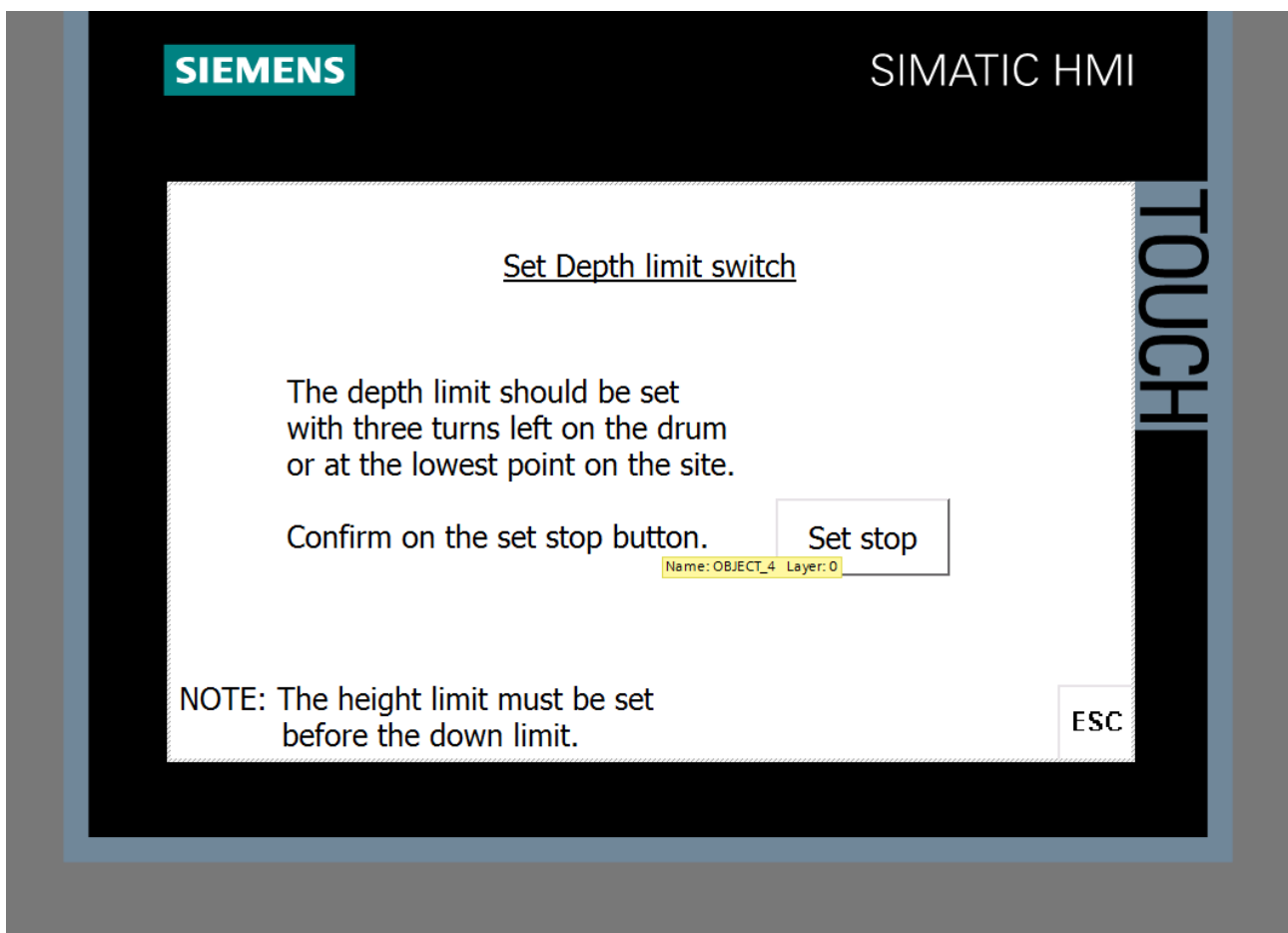

Depth limit setting screen

- If the depth limit is to be set with 3 turns left on the drum then note that the main hoist rope may be longer than the height of the crane. Therefore make sure to un-spool the excess rope on a clean surface to avoid dirt on the main hoist wire. This will shorten the wire rope's lifespan.

## Wire part selection

The wire part indicator in the status screen must correspond to the actual wire part the crane is operating with. If not press the “Wire part” button in the Select screen and select the correct wire part configuration. The selected wire part will be hi-lighted green in the status screen.

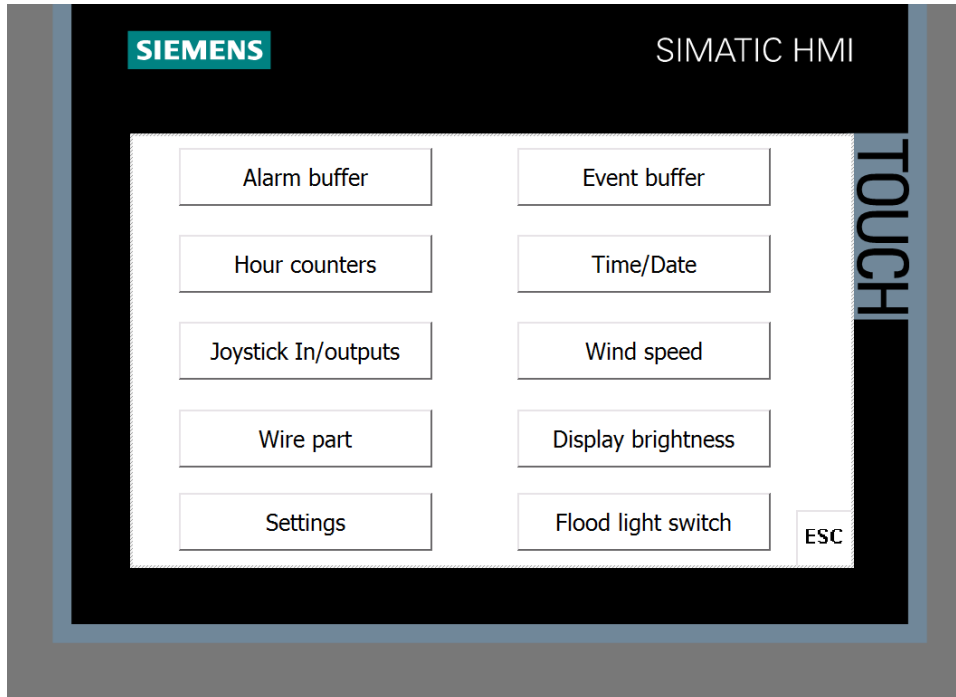

Select screen

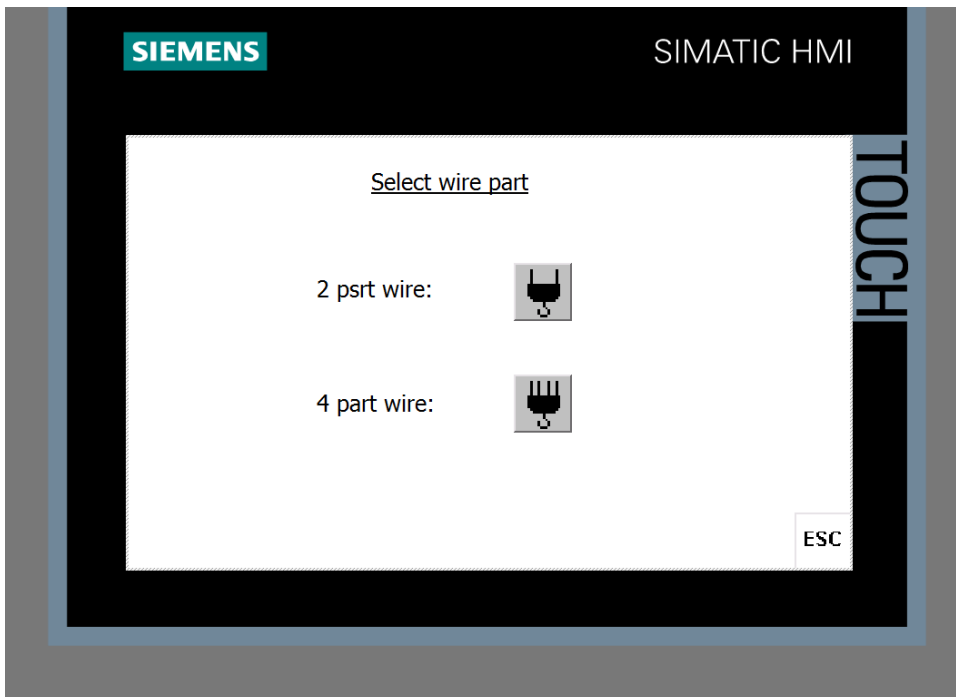

Wire part selection screen

## Load/Moment settings

Before setting the load setting via the display, it is very important that the load amplifier (U12) is set up correctly. The amplifier is equipped with an LED display and 3 buttons; “Arrow up”, “Arrow down” and “OK” button. If necessary go through the amplifiers menu and check the settings. If values are not as shown below, change the value in a menu by pressing the “Arrow up” or “Arrow down” button. Press the “OK” button to go to the next menu point:

### **Load Amplifier PR4116:**

Menu 1.	<b>Status screen;</b> shows input current and output voltage	
Menu 2.	Advanced settings, “ADV.SET”	= NO
Menu 3.	Input type, “IN TYPE”	= current, “CURR”
Menu 4.	Input range, “I.RANGE”	= 0-20mA, “0-20”
Menu 5.	Input unit, “UNIT”	= milliamp, “mA”
Menu 6.	Decimal point, “DEC.P”	= “111.1”
Menu 7.	Display low value, “DISP.LO”	= 0mA, “0”
Menu 8.	Display high value, “DISP.HI”	= 20mA, “20”
Menu 9.	Relay unit, “REL.UN”	= Display, “DISP”
Menu 10.	Relay 1 function, “R1.FUNC”	= Setpoint, “SETP”
Menu 11.	Relay 1 contact, “R1.CONT”	= Normally closed, “N.C.”
Menu 12.	Relay 1 setpoint, “R1.SETP”	= 20 (see section 110% overload)
Menu 13.	Actual direction, “ACT.DIR”	= Increase, “INCR”
Menu 14.	Relay 1 hysteresis, “R1.HYST”	= “0.5”
Menu 15.	Relay 1 on delay, “ON.DEL”	= no on delay, “0”
Menu 16.	Relay 1 off delay, “OFF.DEL”	= no off delay, “0”
Menu 17.	Relay 2 function, “R2.FUNC”	= Setpoint, “SETP”
Menu 18.	Relay 2 contact, “R2.CONT”	= Normally closed, “N.C.”
Menu 19.	Relay 2 setpoint, “R2.SETP”	= 20 (see section 110% overload)
Menu 20.	Actual direction, “ACT.DIR”	= Increase, “INCR”
Menu 21.	Relay 2 hysteresis, “R1.HYST”	= “0.5”
Menu 22.	Relay 2 on delay, “ON.DEL”	= no on delay, “0”
Menu 23.	Relay 2 off delay, “OFF.DEL”	= no off delay, “0”
Menu 24.	Analog output, “ANA.OUT”	= Voltage, “VOLT”
Menu 25.	Output range, “O.RANGE”	= 0-10Vdc, “0-10”
Menu 26.	“Wait!” = saving entered values and going back to status screen	

NOTE: Normally only the “zero” and “maximum” load input values [mA] have to be noted for later use.

## Load settings

**Note:** Ensure the correct wire part has been set in the display before the maximum load setting is carried out.

- To set the overload equipment press the "Load setting" button on the screen under the Setting menu

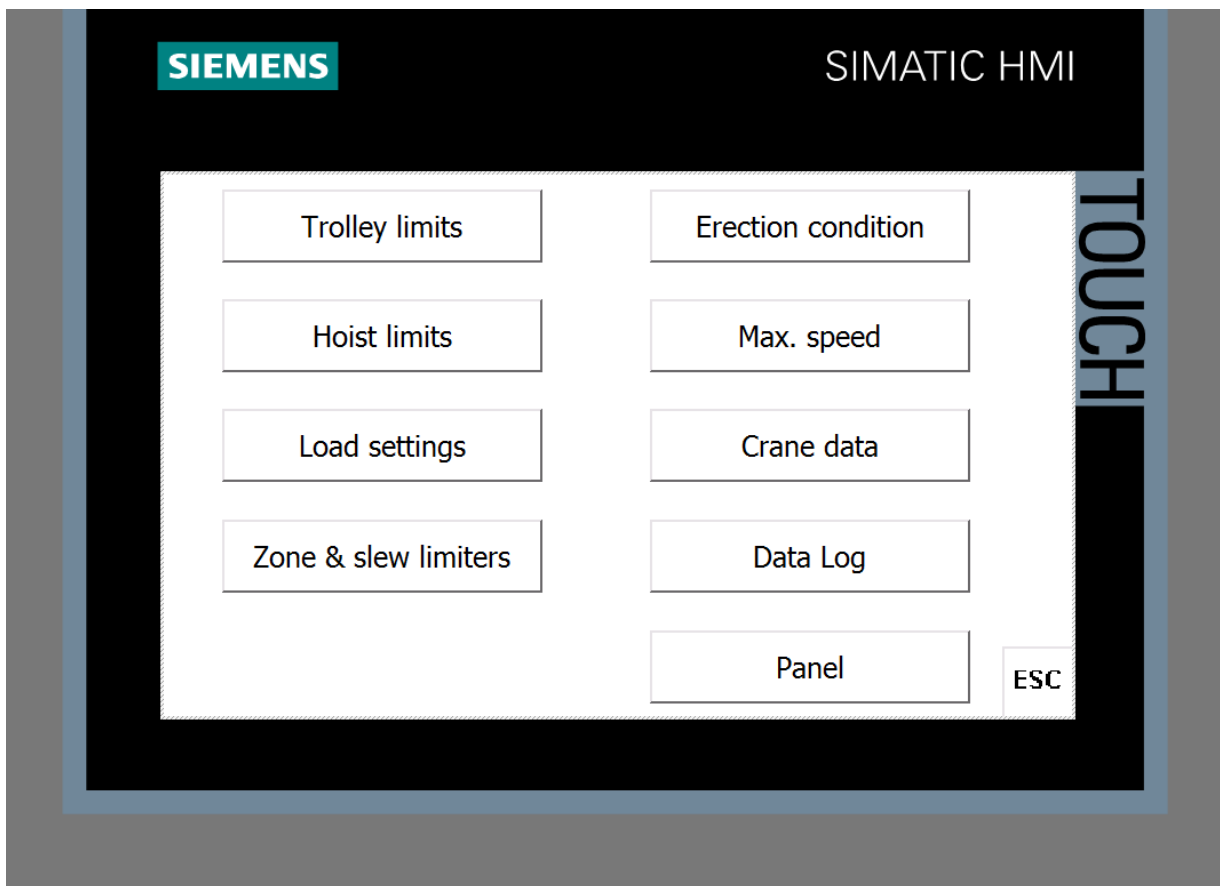

Setting screen



## Hoist zero load setting

**NOTE: Remember to zero adjust the U12 load amplifier before carrying out the load setting!**

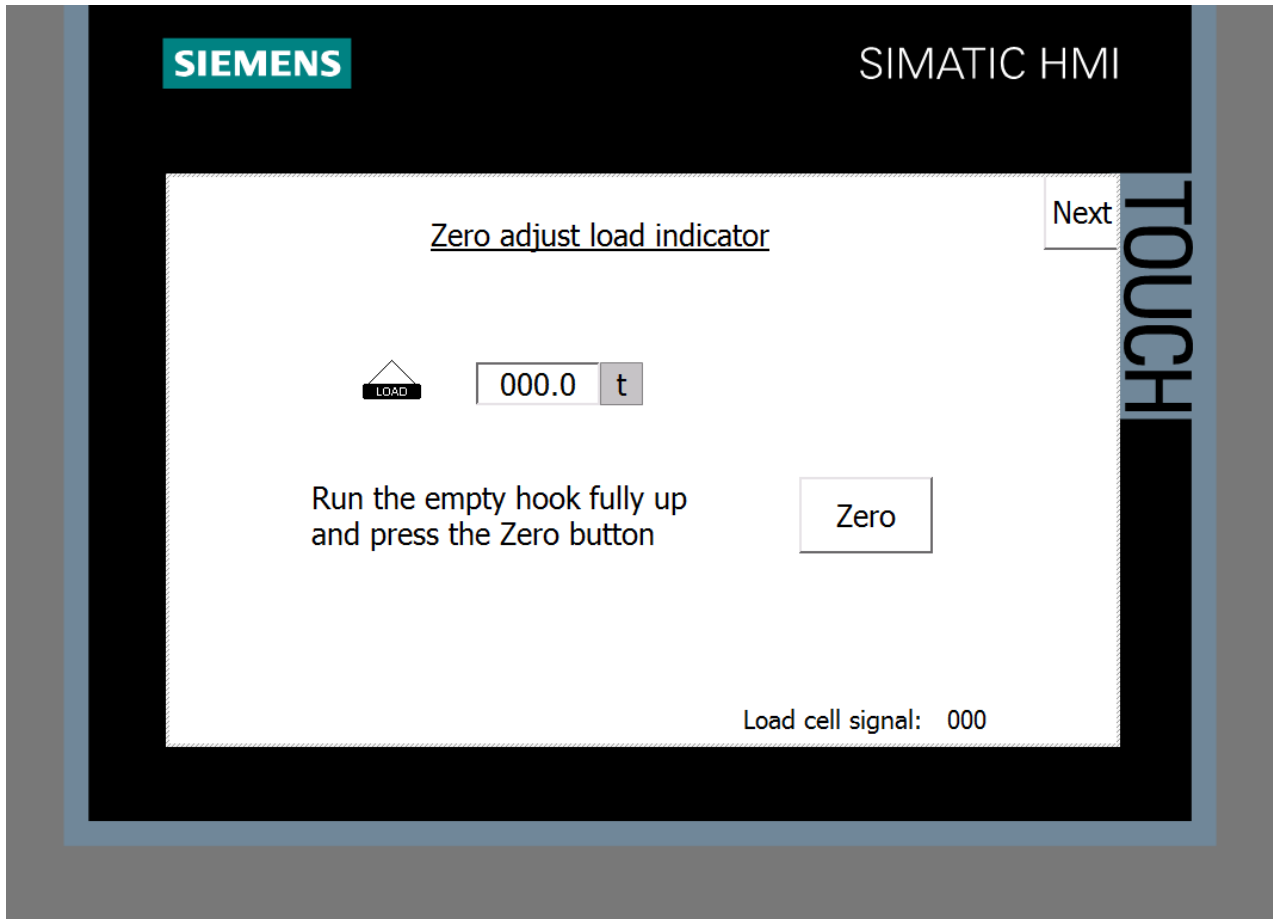

Hoist zero load setting screen

- To zero adjust the load indicator run the empty hook fully up to the height limit and press the "Zero" button. The load indicator will be reset to zero

Note: The load cell signal should be within 20-25%. 20% is equal to 2Vdc from the load amplifier, which is the no load signal. If the signal is not correct, check the load cell connection.

- Press the Next button and the Maximum load setting screen appears

## Hoist maximum load setting

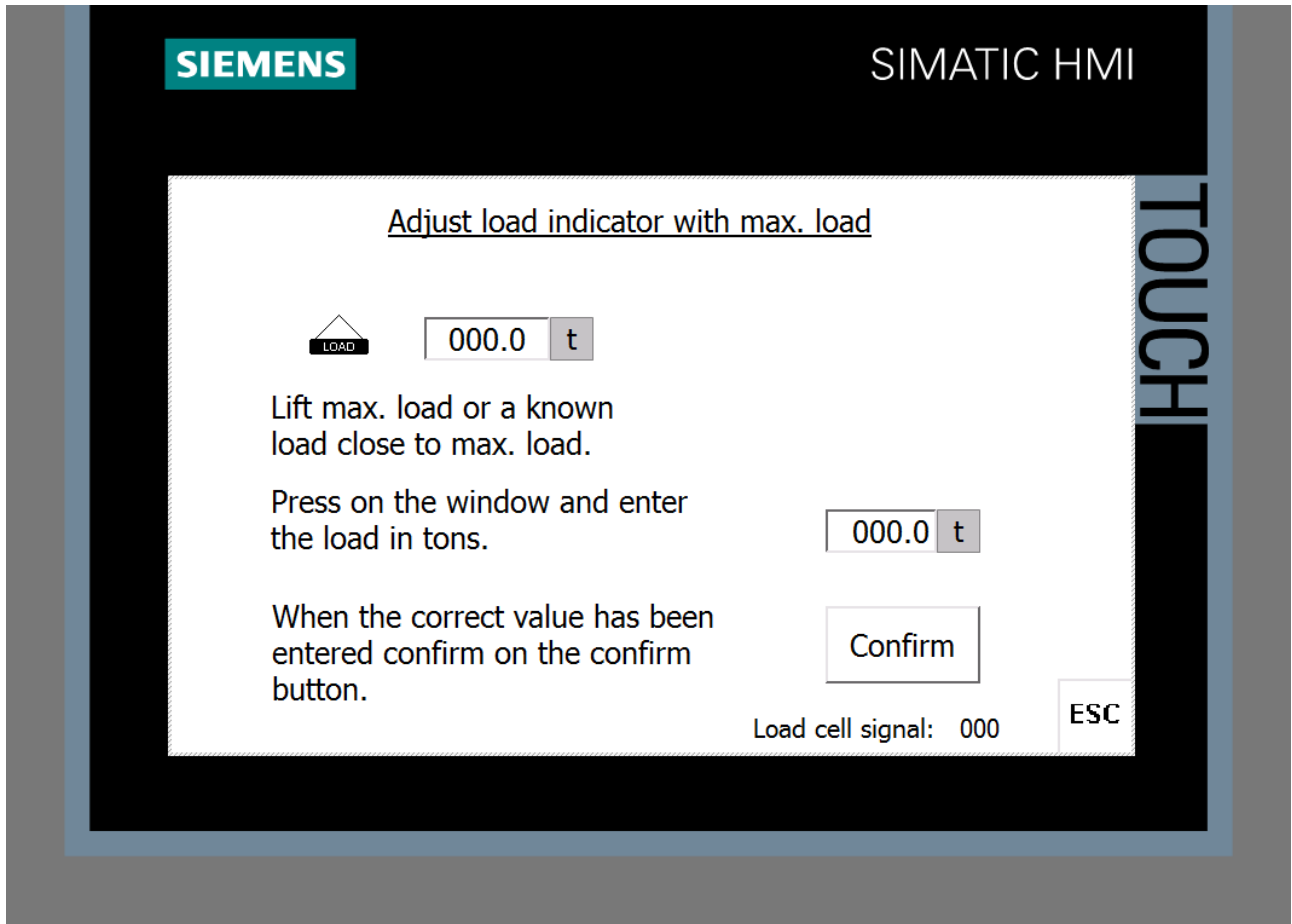

Main hoist load setting screen

- Lift a load close to maximum load (min. 70% of max. load)
- Let the crane rest and then press on the indicator window and a keyboard appears on the screen. Type in the actual load on the hook.
- When the correct value has been entered press the “Confirm” button. The overload equipment has now been calibrated.

Note: The load cell signal should be approx. 50-75% depending on the flee angle of the load cell sheave. If the signal is not correct check the load cell connection.

- Press the ESC button to return to the Setting menu.

## **Moment**

The load chart for the delivered jib configuration has been entered in the PLC program.

The set trolley radius together with the entered load charts gives the Safe Working Load (SWL), which is displayed in the Status screen next to the load indicator. Therefore it is very important that the trolley radius is set correctly.

SWL shows the maximum load, which may be lifted at the given trolley position. If the load hook exceeds the SWL the lifting and trolley out function will be stopped.

A mechanical moment safety switch also has to be set to 110% moment. Lift 110% moment, at this point adjust the bolt on the moment device, so it activates the switch. This signal is hardwired to the safety relay D1 and with emergency stop the crane. An alarm will also appear and inform the crane driver that the switch has been activated.

## **110% overload**

The load amplifier is equipped with two relay outputs, where one contact must be set to a 110% overload situation (110% load safety relay). If there are conductors connected to terminals 21 & 22 then it is relay 1 where the 110% value must be entered. If there are conductors connected to terminals 23 & 24 then it is relay 2 where the 110% value must be entered. If in doubt set both relays to the 110% overload value.

To calculate the 110% overload value, utilise the equation below entering the noted min. and max. values:

$$(x_2 - x_1) \cdot 1.1 + x_1 = x_3$$

The result  $x_3$  is the mA signal to be entered in Menu 12 or Menu 19 under section “load settings”. Now the amplifier switch will open at the set 110% overload value.

## Slew encoder deactivation/activation

**Note:** Slew limits and zoning is an option and an optional slew encoder has to be purchased to utilize these functions.

- When no slew encoder is connected to the PLC the slew encoder connection has to be deactivated via the slew encoder deact/activation screen on the settings screen.
- If the slew encoder is activated but not connected the PLC program will still work as it should, but a red LED indicator on the PLC will blink.

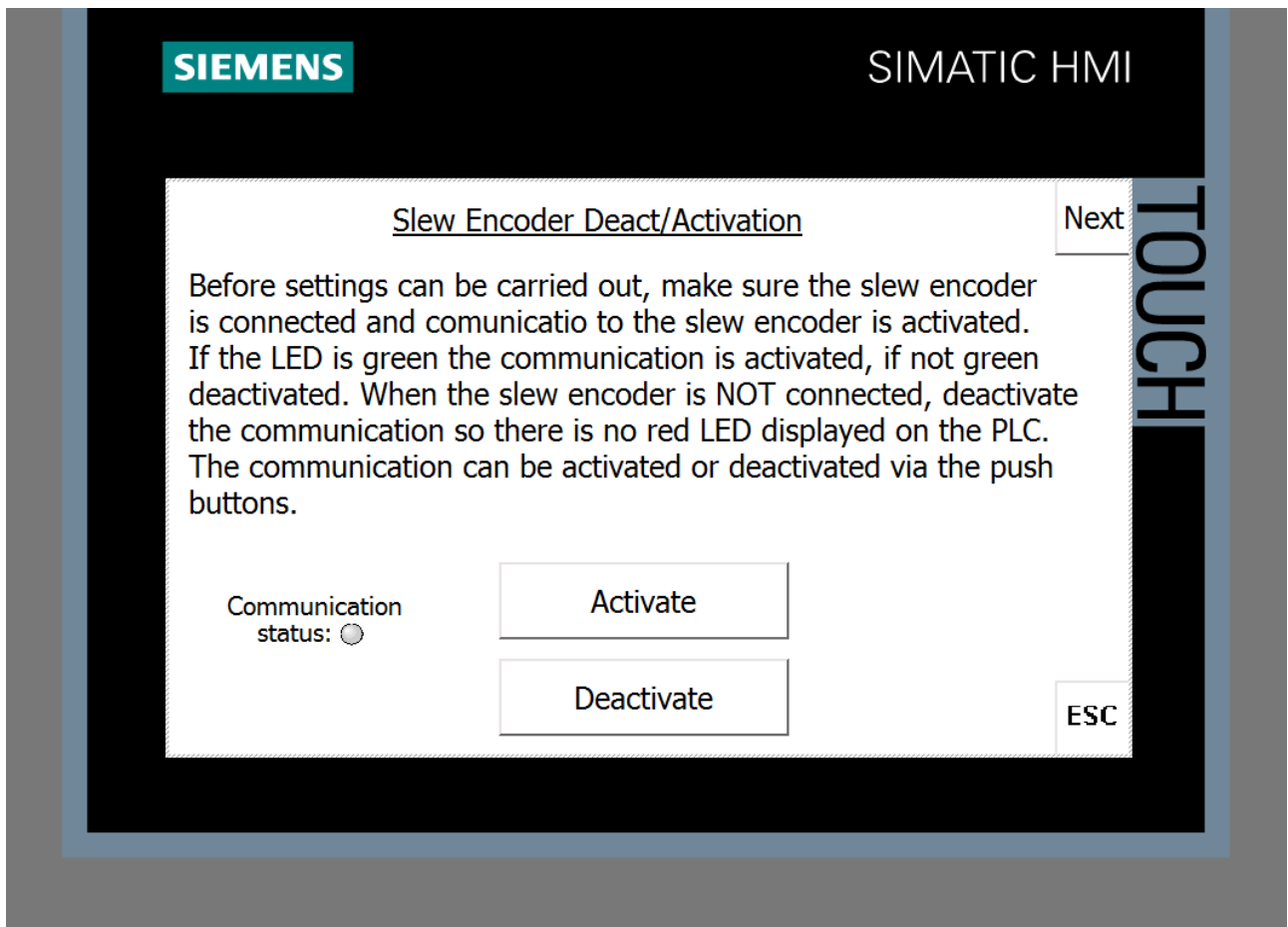

Slew encoder deact/activation screen

## Slew limits

- Press the "Slew limit" button in the screen setting screen

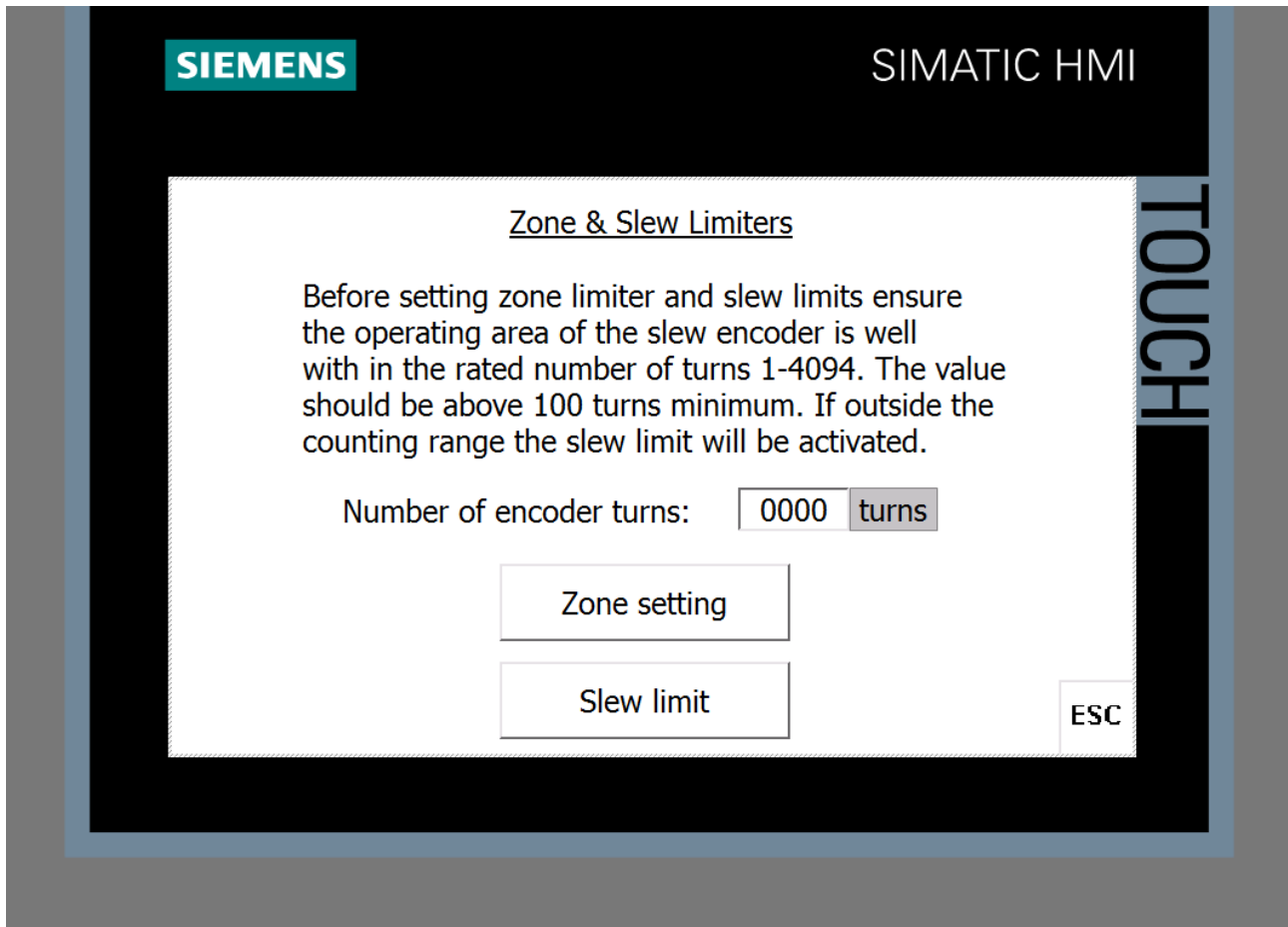

Encoder turns screen

- Before any slew limits are set, ensure the slew encoder is within the working range. The rated number of encoder turns must be within 1 to 4094. Before doing any settings the number of encoder turns should be minimum 100. If this is not the case mechanically turn the slew encoder shaft until the number of encoder turns are above 100.
- To set slew limits press the "Slew limit" button

## Slew limit settings

- Press the "Slew limit" button in the screen setting screen

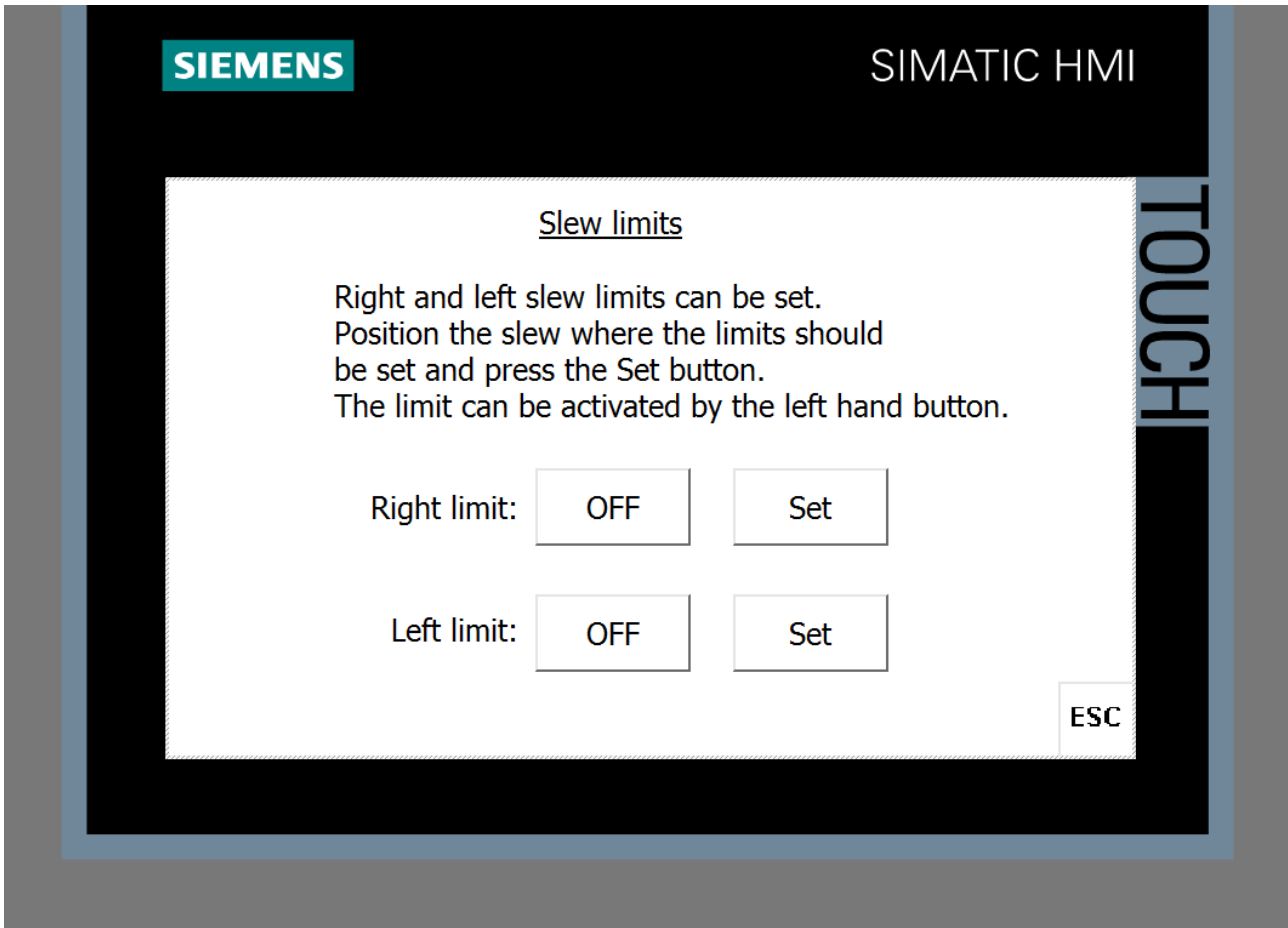

Slew limit settings

The slew limits are mostly used for main cable protection. A slew left limit and a slew right limit can be set.

- Slew the crane to the left position where the slew motion shall stop.
- Press the left limit "Set" button to set the slew left limit
- Press the left limit "OFF" button to activate the limit. The button will change to "Active"
- Press the left limit "Active" button to deactivate the limit. The button will change to "OFF"
  
- Slew the crane to the right position where the slew motion shall stop.
- Press the right limit "Set" button to set the slew right limit
- Press the right limit "OFF" button to activate the limit. The button will change to "Active"
- Press the right limit "Active" button to deactivate the limit. The button will change to "OFF"

## Zone setting

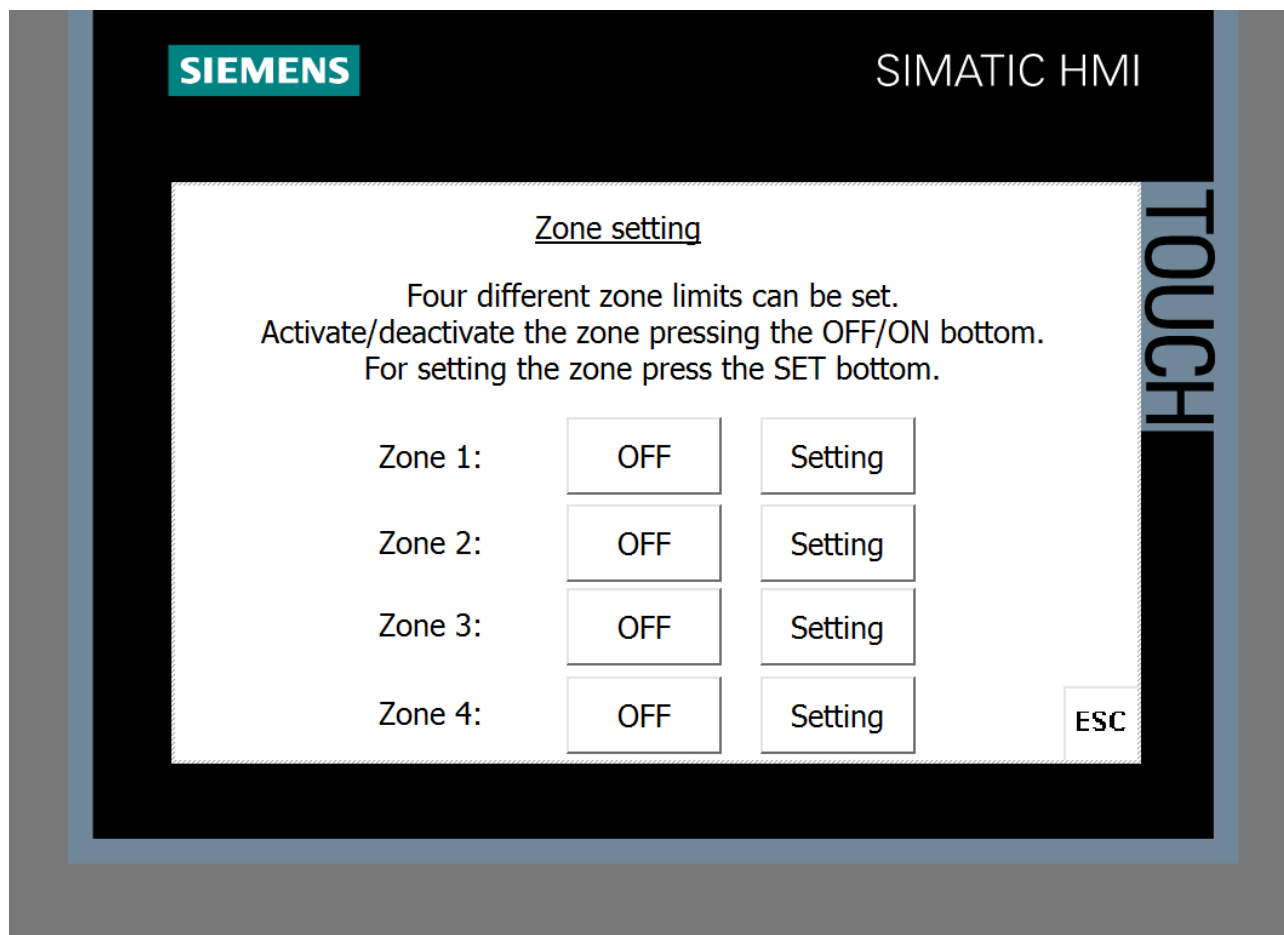

Zone setting screen

Four zone limits can be set.

Each of the four zone limits can be activated and deactivated by pressing the “OFF”/”Activated” button for each zone limits.

To set the zone limit press the “SETTING” button.

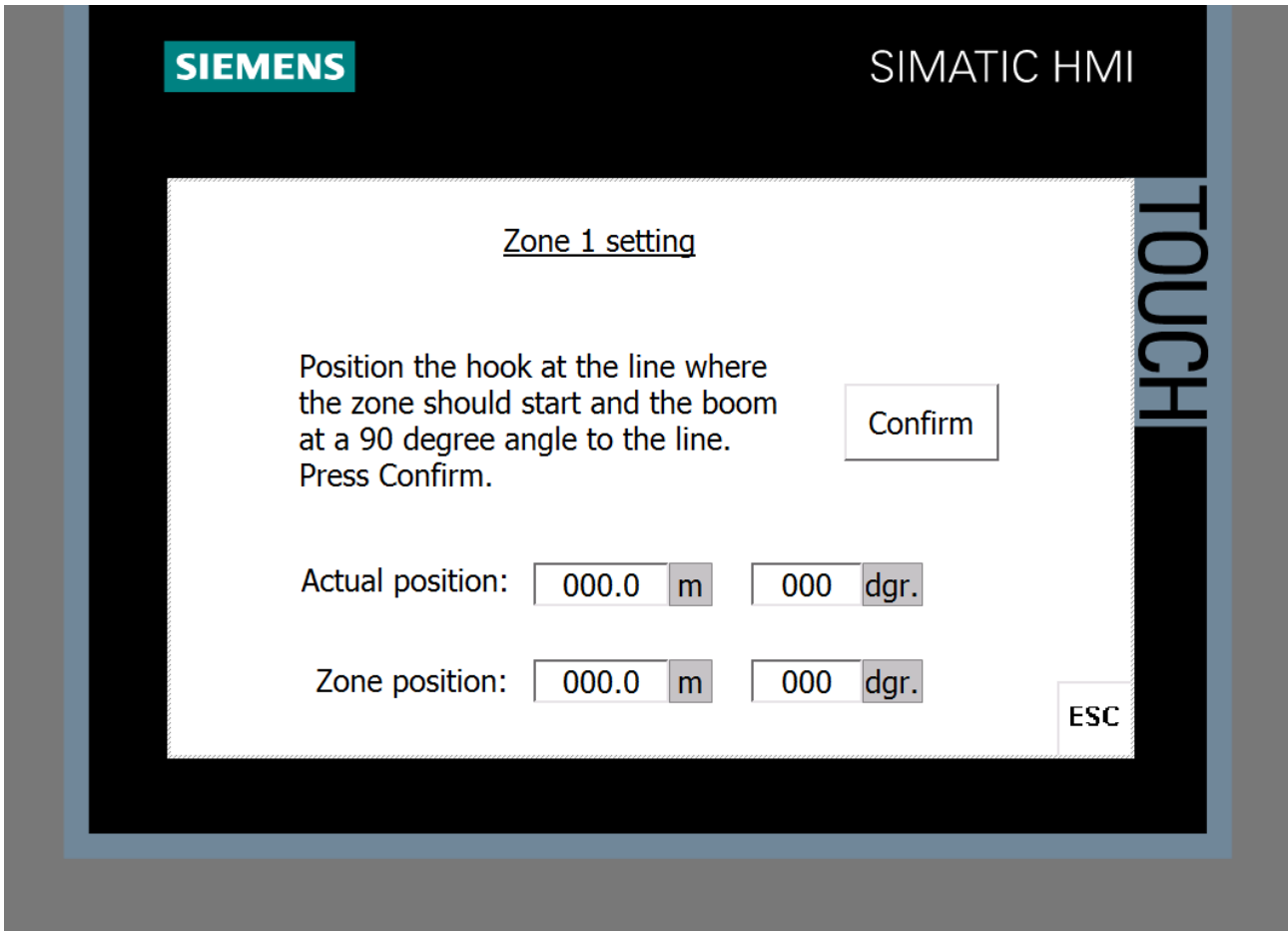

Zone 1 setting

- Place the hook at a 90 degree angle to the straight line where the zone limiter should stop the crane
- Press the “Confirm” button.

The trolley out motion and the slew motion will now be stopped if the hook is about to enter the set restricted zone.



## Service

Via the select screen the following can be entered:

- alarm/event buffers
- hour counters
- joystick in/outputs & voltage
- wind speed configuration
- time & date
- screen brightness
- flood light D52 relay activation
- max. speed function

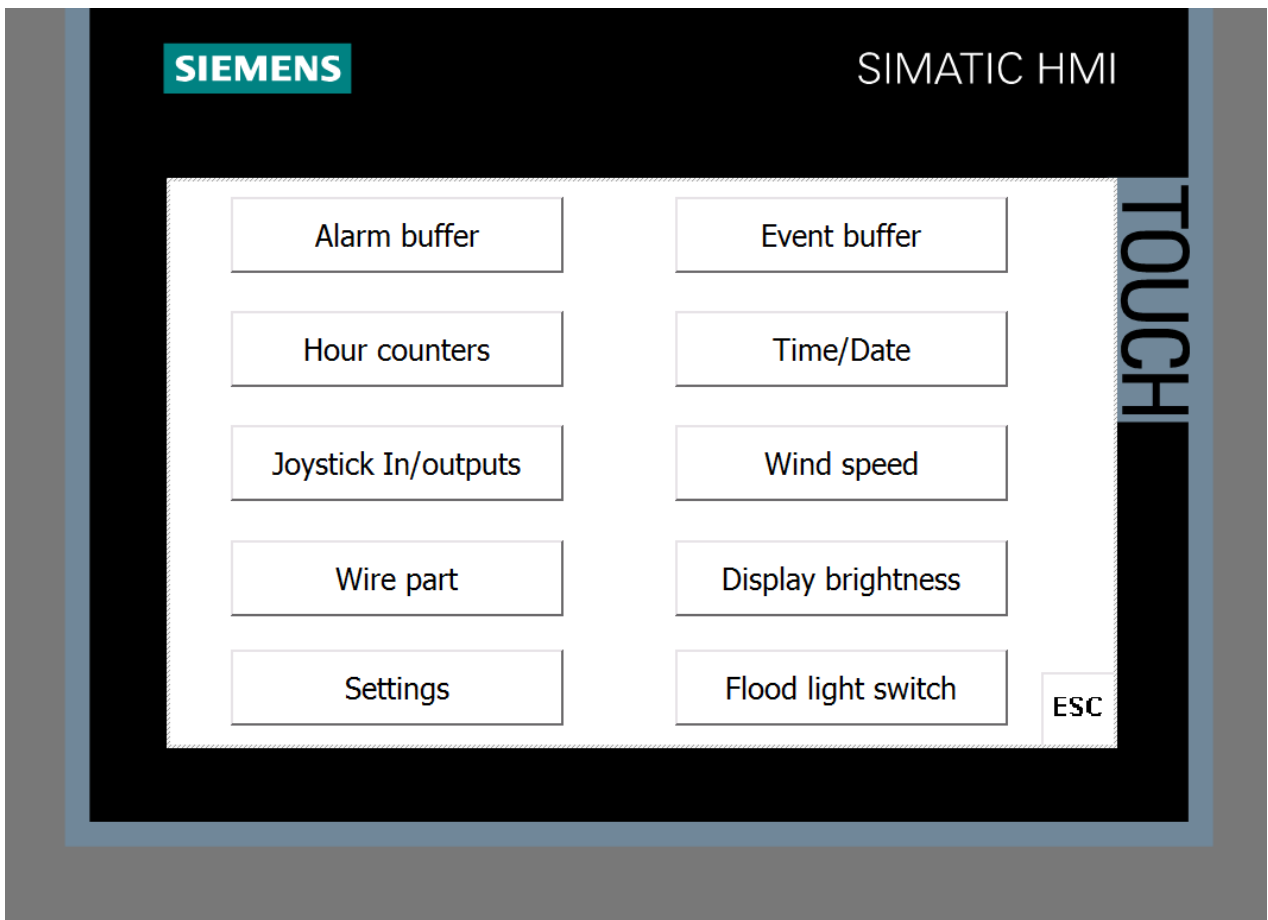

Setting screen

## Alarm/event buffer

The last 99 alarms or events can be read in these screens. The buffers are circular logs and above 99 logs the last log will be deleted. The buffer is an internal memory bank and will be deleted, if the control system is left powerless for a longer period of time.

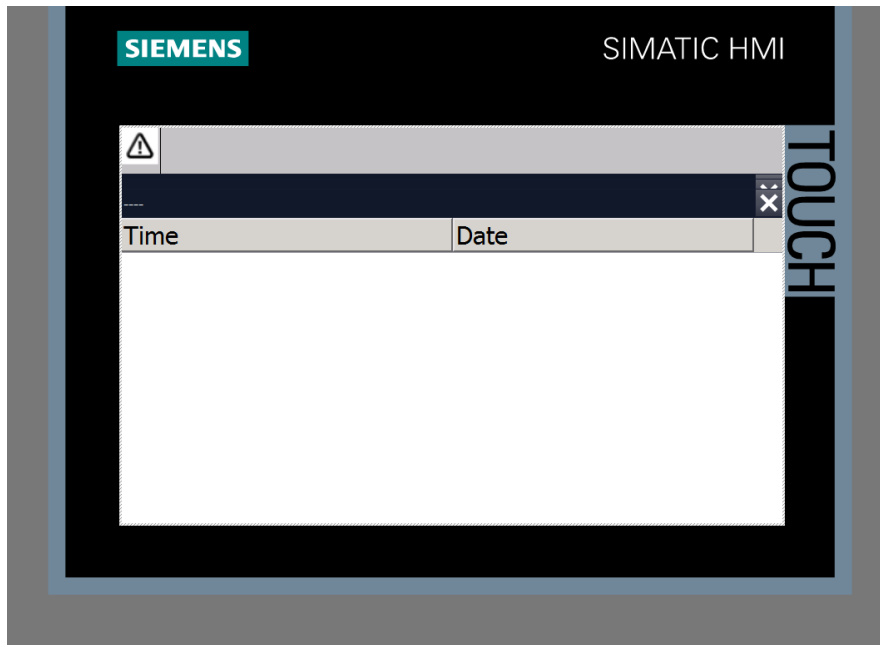

Alarm/event buffer

## Hour counters

There is an active hour counter for each function. The “total” hour count is the active operation time for the infeed. Access to this screen is through the Select screen.

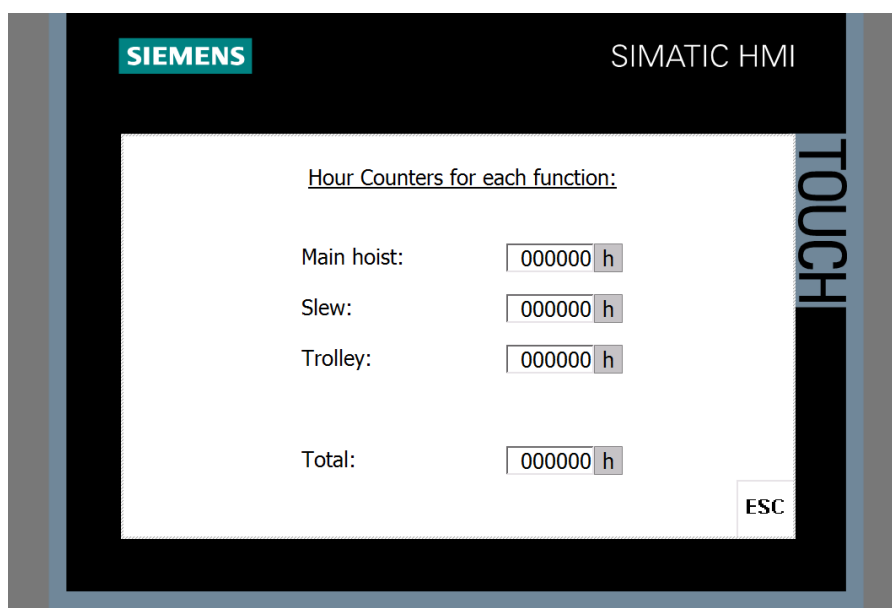

Hour counter screen

## Joystick signals

The joystick signals can be checked via the display under the. Access to this screen is through the Select screen.

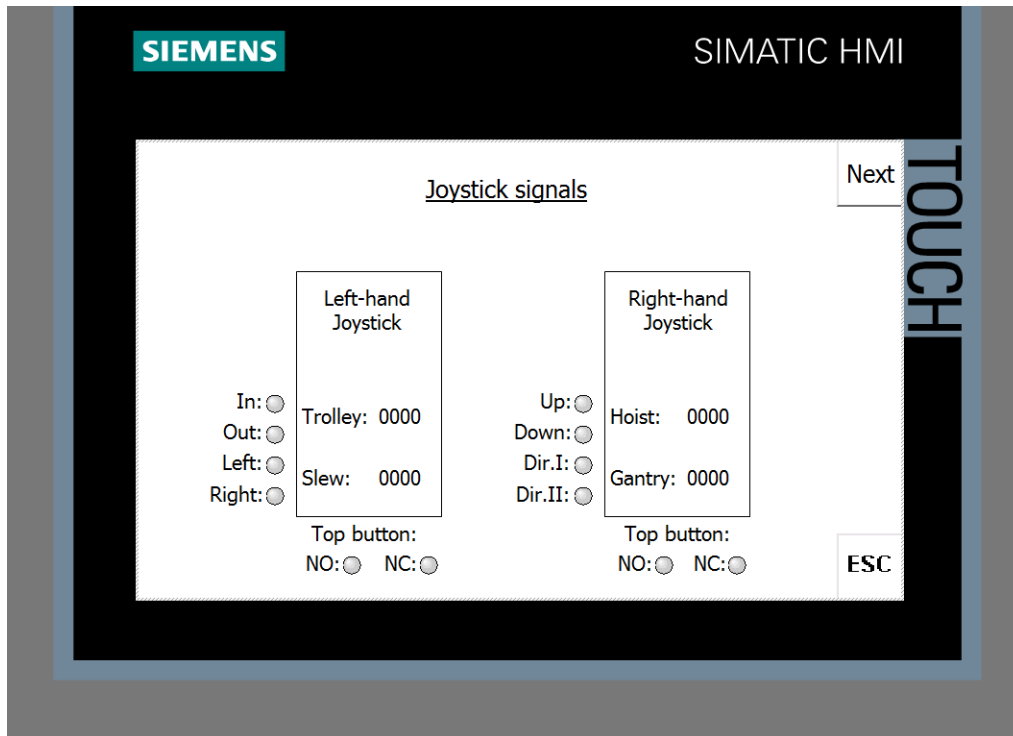

Joystick inputs screen

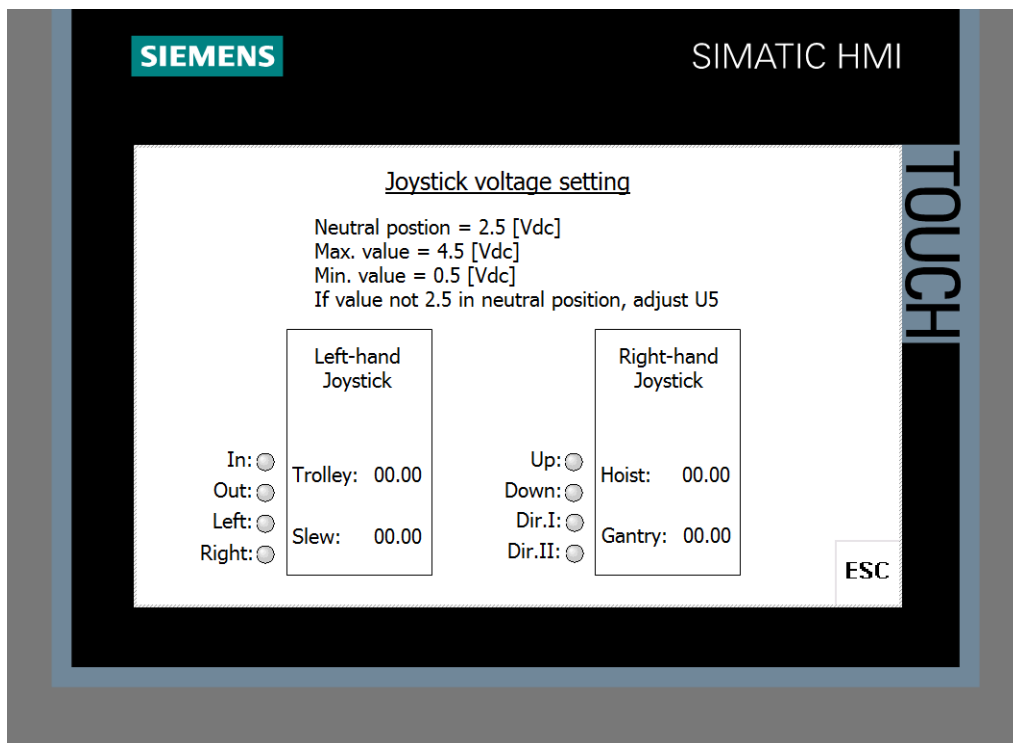

Joystick voltages screen

## Wind speed configuration

- The crane driver can choose to have the wind speed in m/s or km/h
- Press the "Wind speed" button in the select screen
- Press the button

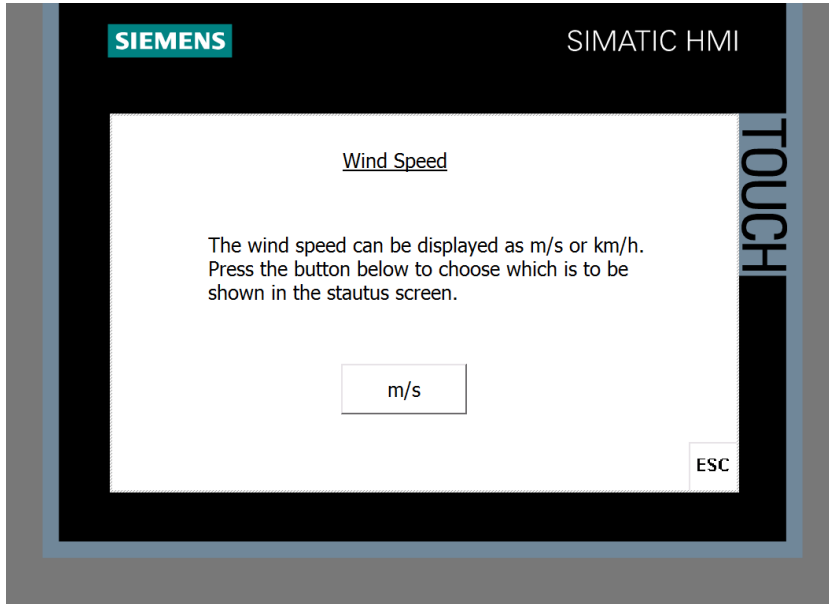

Wind speed screen

## Set time & date

To set the time or date

- Press the time/date window on the screen
- A keyboard appears, enter time/date with the corresponding characters as shown
- 

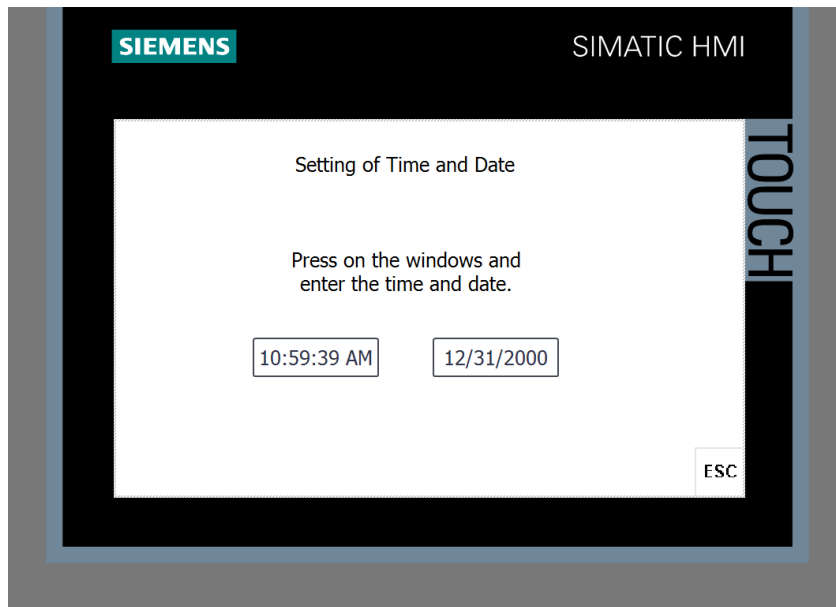

Time & date screen

## Display brightness

Press the display brightness button on the select screen. Touch and slide the slide button up to increase brightness and down to decrease brightness.

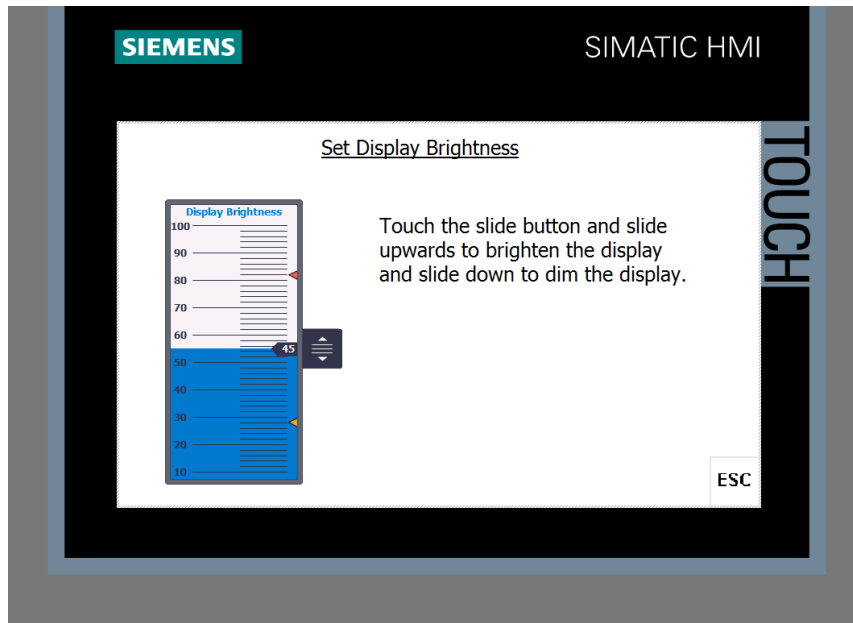

Display brightness screen

## Flood light switch

To switch flood light relay D52

- Press the “Flood light switch” button on the select screen
- Everytime the button is pressed, relay D52 will toggle between ON and OFF

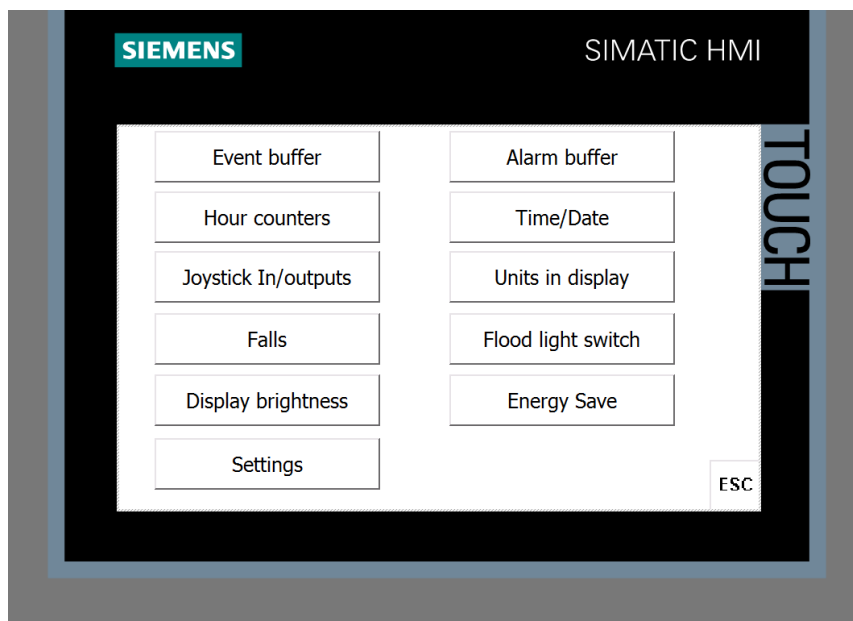

Select screen

## Max. speed

- Press the "Max. speed" button in the select screen

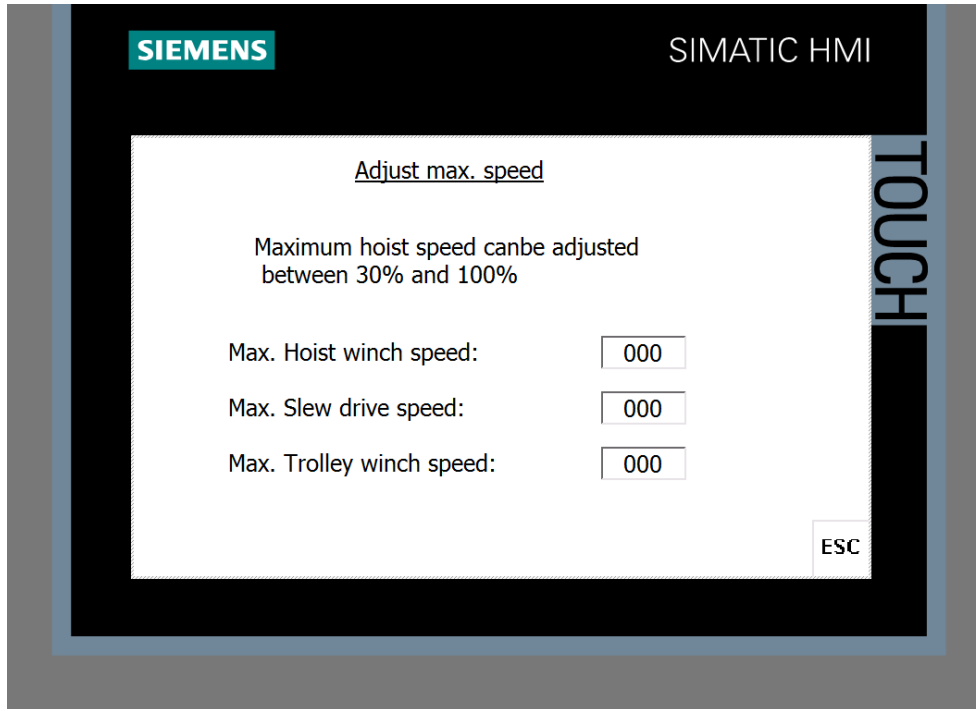

Max. speed screen

Here the maximum speed of the hoist, slew or trolley can individually be reduced to a minimum of 30% of the rated speed. A value between 30% and 100% can be chosen, factory setting is 100%

- Press the indicator window of any of the three crane movements
- A keyboard will appear. Enter the maximum speed desired and press enter
- The chosen crane movement speed is now reduced to the entered value

## Data Logging

### Logs:

- **Load logs:** All lifts above 15% of max. SWL value will be recorded. The system will record the start of the lift where the starting time and date is recorded together with the actual position of the start of the lift. The load will be recorded as 0.0 tons to indicate the start of the lift. When the load is unloaded the unloading time and date is recorded together with the weight of the load and the unloading radius. Safe working load “SWL”, is also recorded at every lift.
- **ID & operating hours logs:** Every active operating hour will be recorded and the log will state crane model and serial number.
- **Wind speed logs:** Log every wind speed above 15 m/s every min or if wind speed has altered +/-2m/s
- **Alarm logs:** All alarms will be recorded. An alarm is a warning which may stop one or more functions which are outside normal operation. The operator will also receive an audio and visual warning when an alarm has been triggered. The operator has to acknowledge alarms. The visual alarm is a pop up menu which will appear in the display. E.g. “Maximum current breaker for hoist brake Q13 is tripped”
- **Event logs:** All events will be recorded. An event is a warning which may control motor speeds or even stop functions which are within normal operation. The operator will also receive a visual text when an event has been triggered. Events will appear in the upper line of the operator display. E.g. “Hoist 2<sup>nd</sup> upper limit is activated”
- **Destription:** All logs are recorded with a date and time stamp.
  - In the settings screen press the “Data Log” button
  - On the data log screen the logged data will be stored and read directly from the MMC flash memory card on the back of the panel.

Note: New logs after entering the data log screen will only be visible after leaving the data log screen and entering it again.

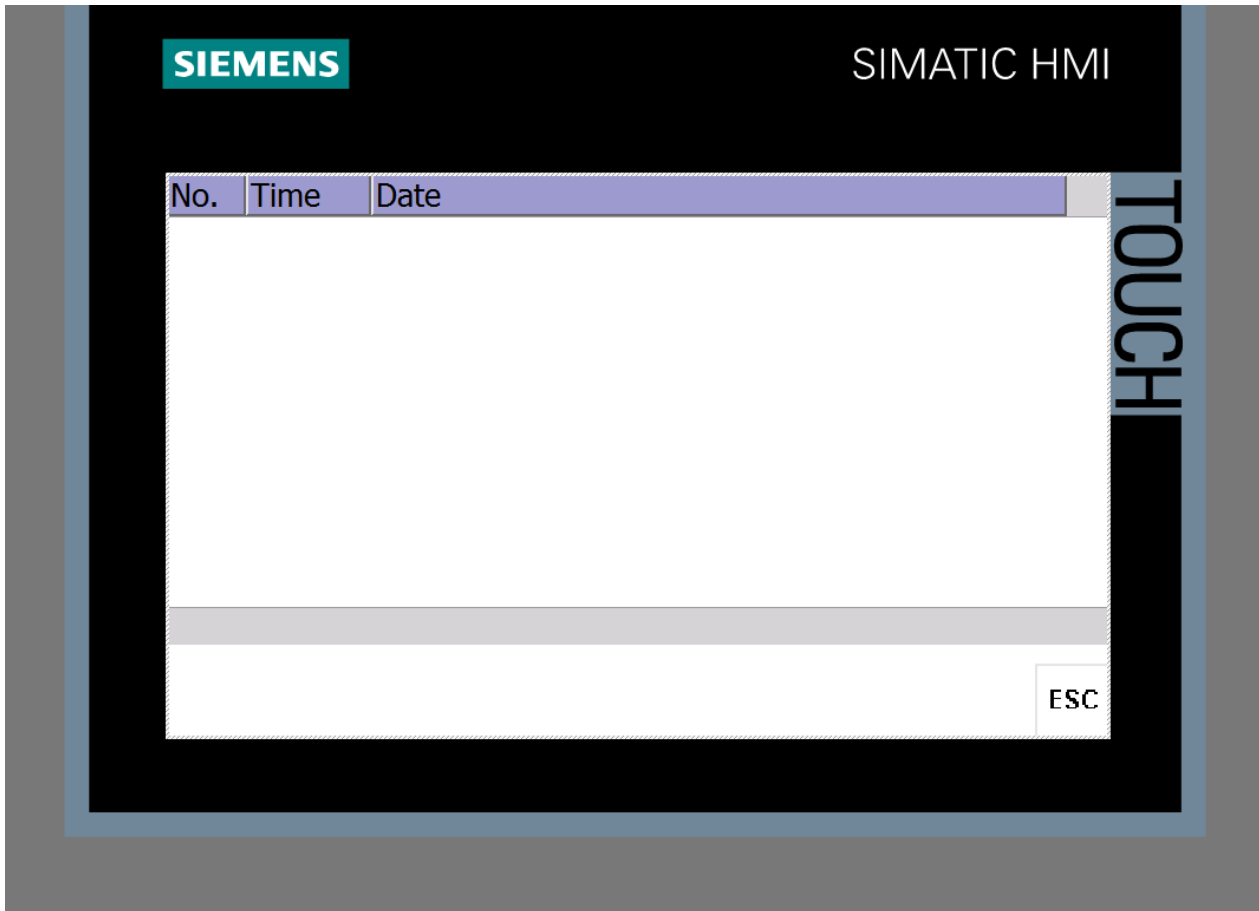

Data log screen

**Data downloading:** All logs are recorded onto the MMC flash memory card fitted into the display. The logs are saved as a Comma Separated Value (.csv) file which can be viewed via Excel. The log is a cyclic logging system and 50000 logs will be registered. The MMC flash memory card can be removed from the display and with a standard flash card reader the file can be copied to a lap top or a stationery office computer.

- Before removing the MMC memory card turn OFF the power to the display
- Remove the MMC card situated on the left-hand side of the display.
- Now either download the files on the MMC card to a lab top computer or replace the MMC card with the extra MMC card.\*
- When a MMC card has been inserted into the display turn the power back ON
- Pressing the **ESC** button will activate the previous screen

**\*Downloading the .csv file:** Utilizing a standard MMC flash card reader, copy the .csv file to a computer. After copying the file either delete or keep the file on the MMC card. If the file is kept, the logging will continue on the existing file. If the file is deleted new files will be generated when put into the display again. If 2 cards are used we recommend that all files be deleted after being downloaded.



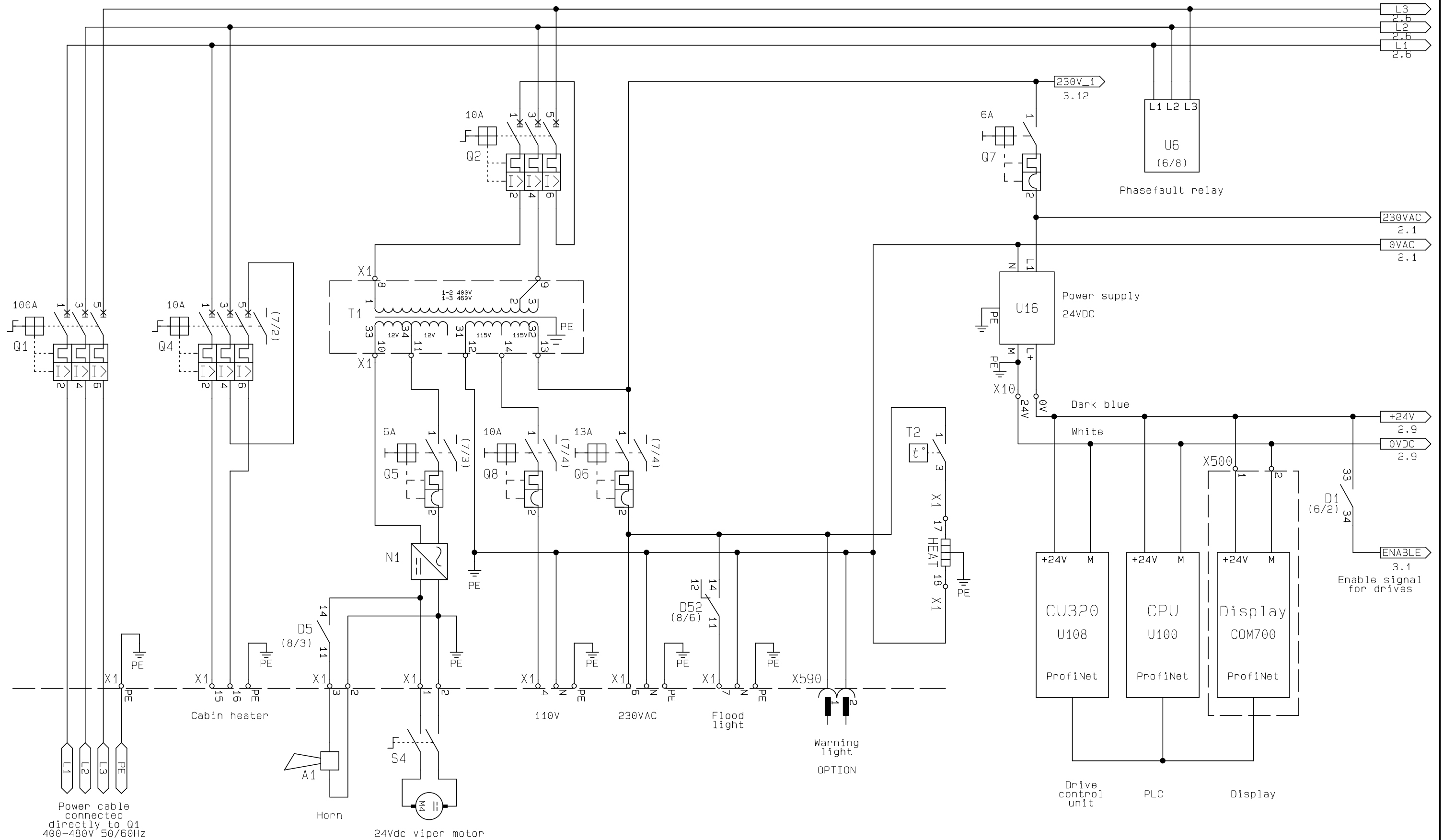

Power cable connected directly to Q1 400-480V 50/60Hz

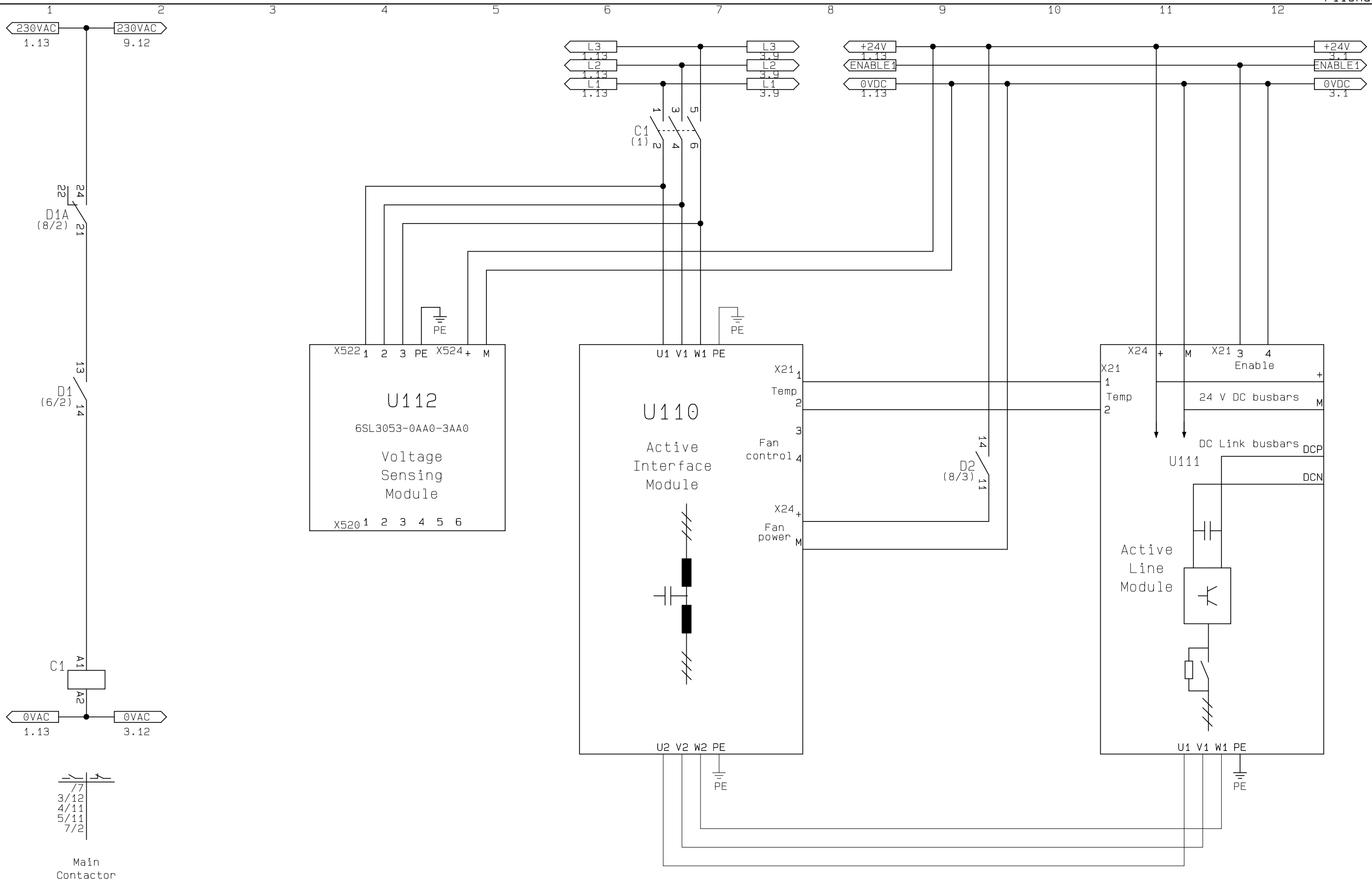

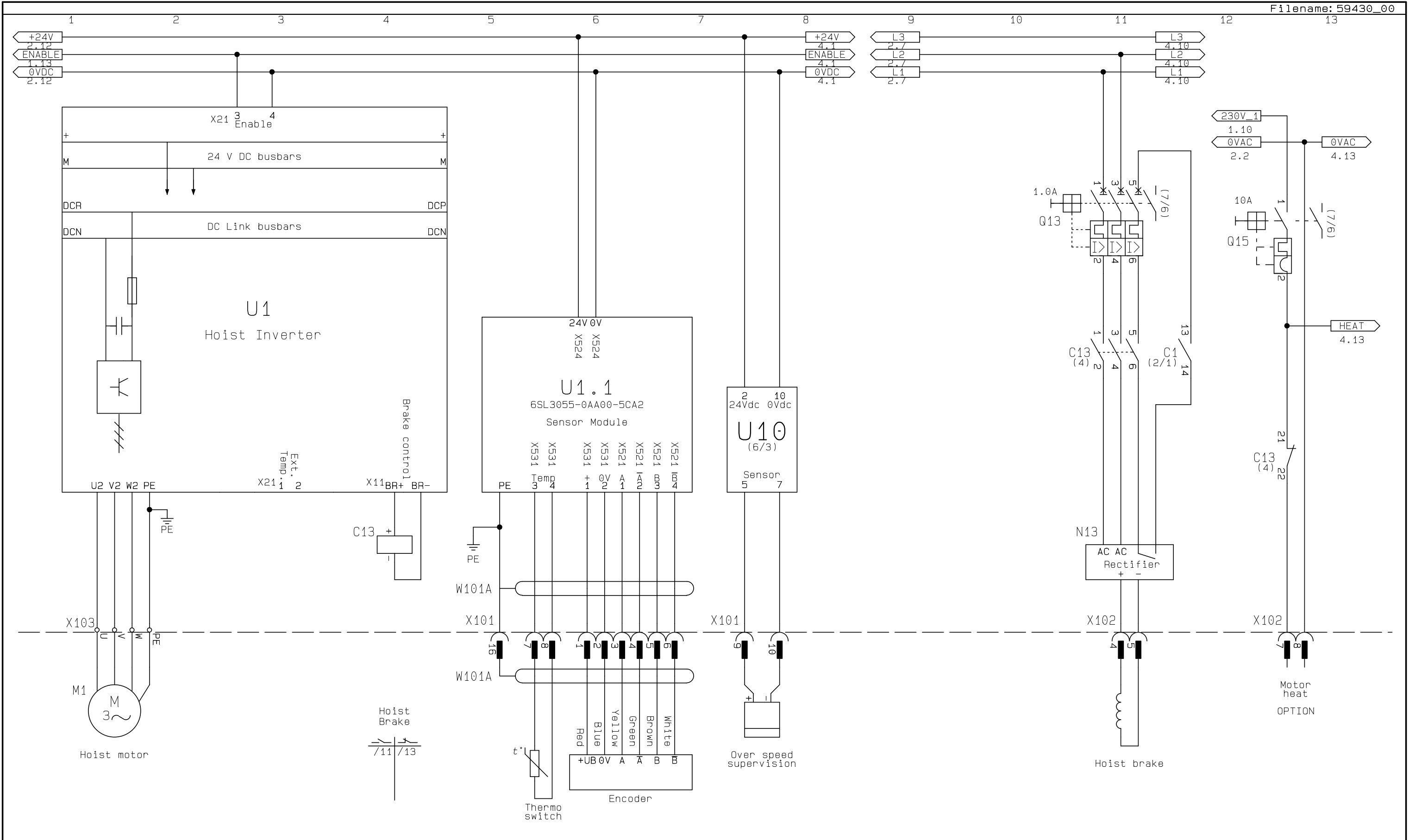

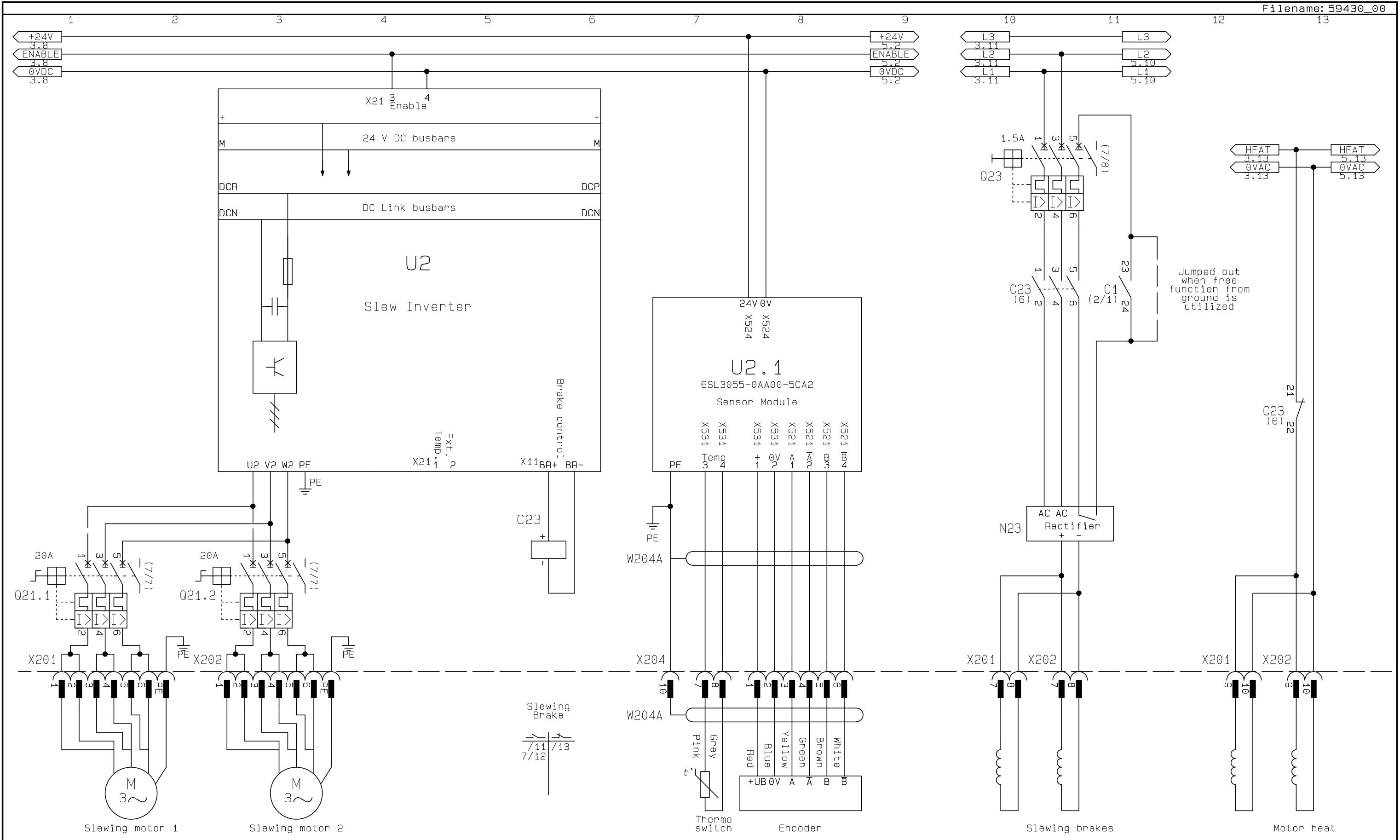

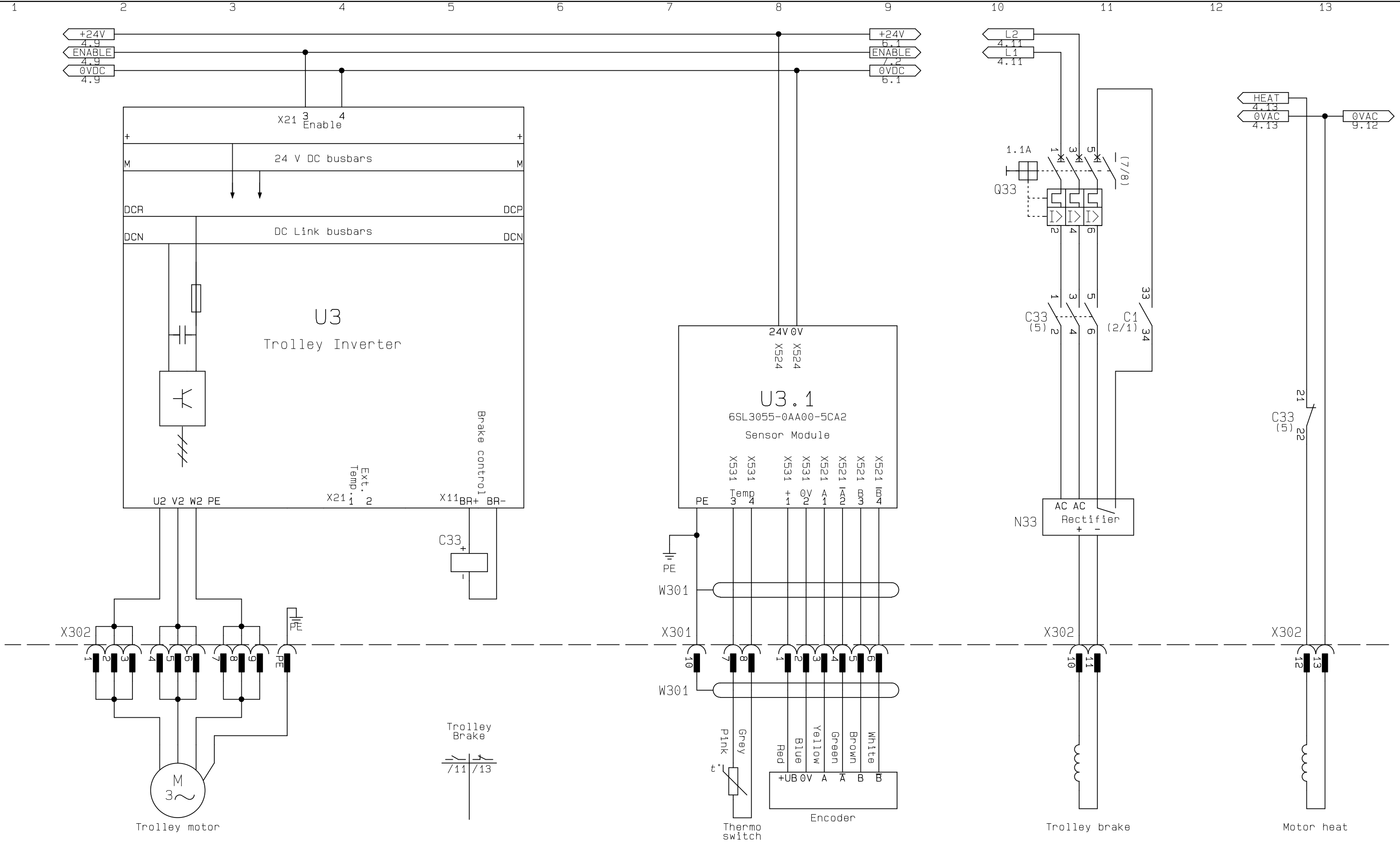

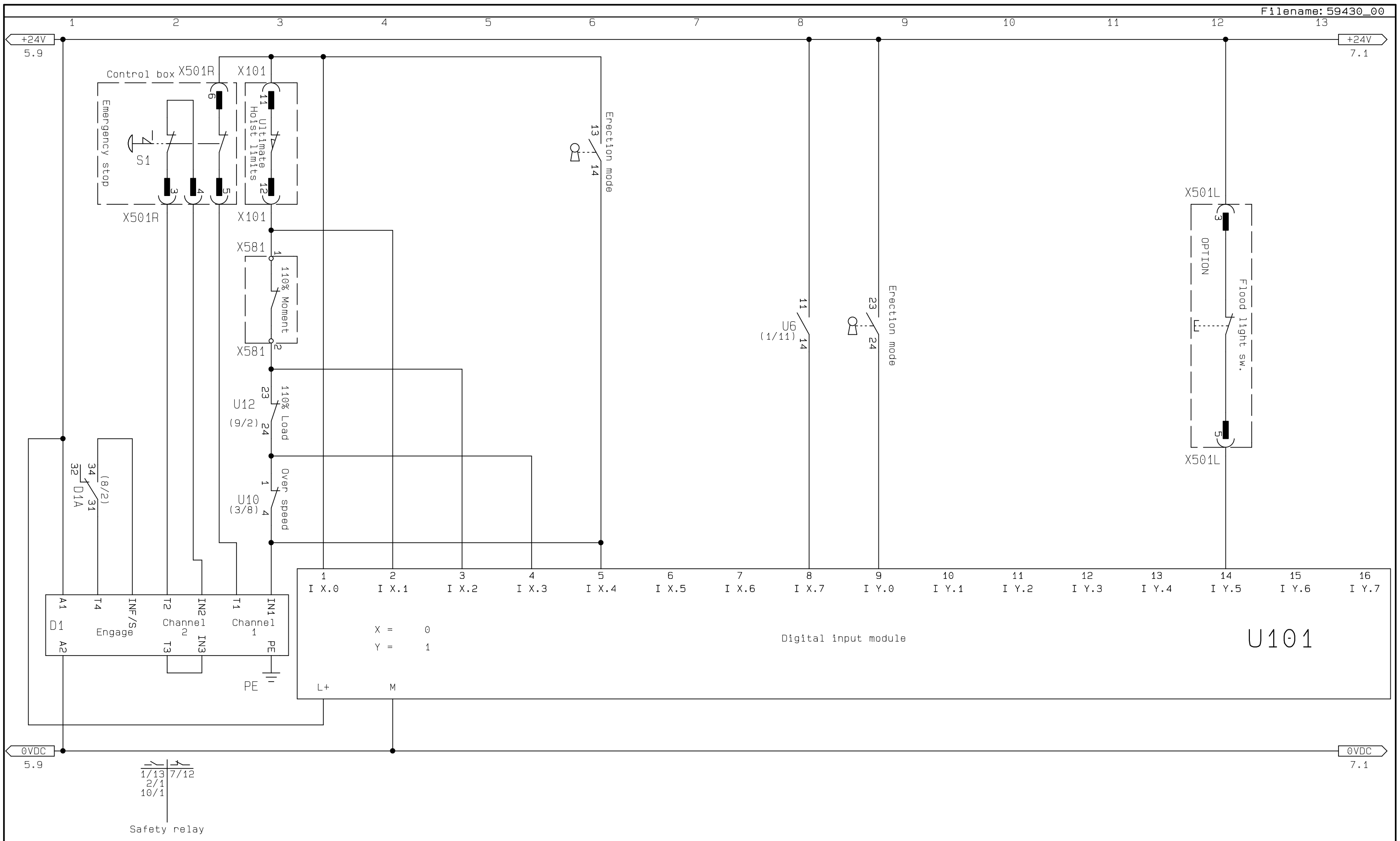

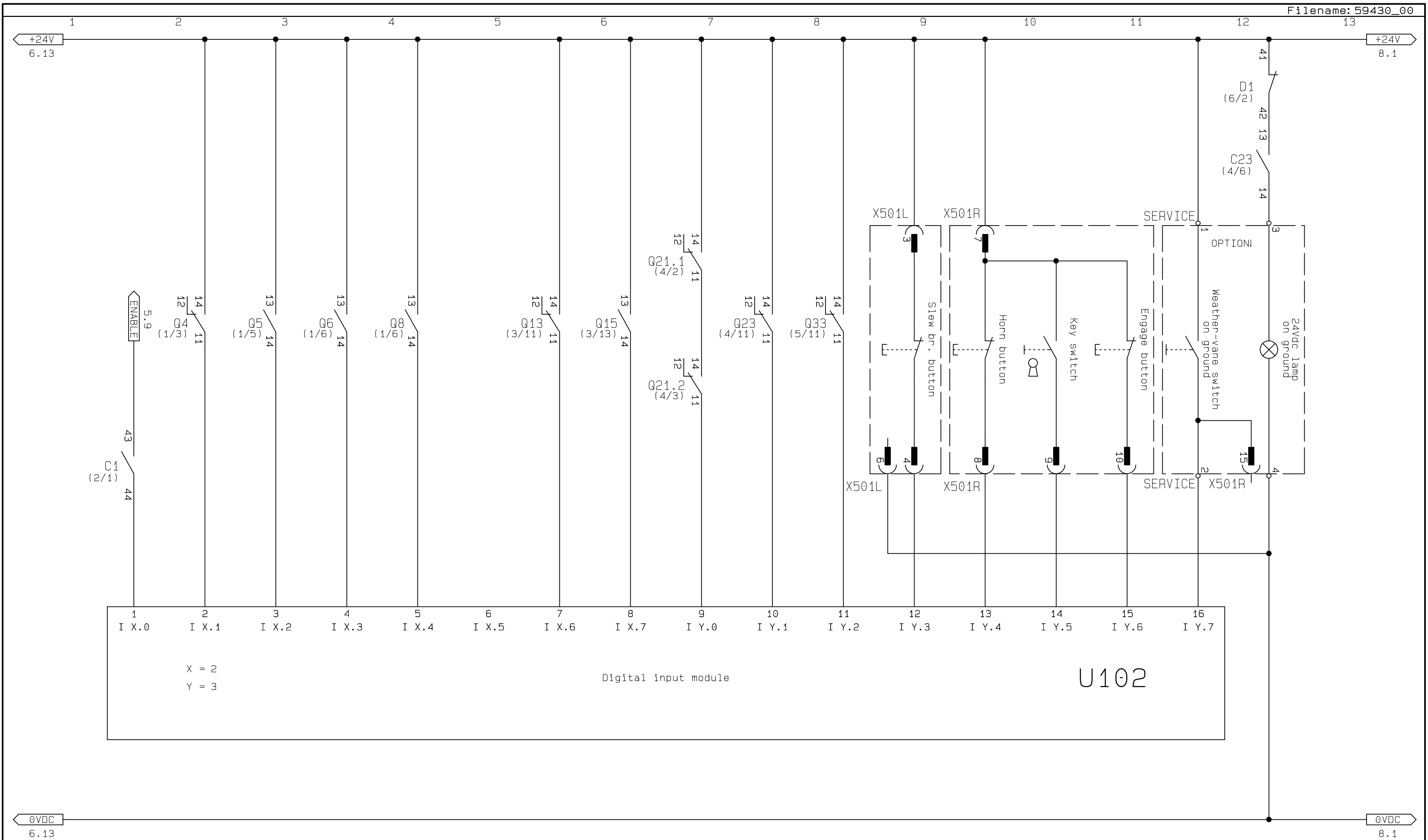

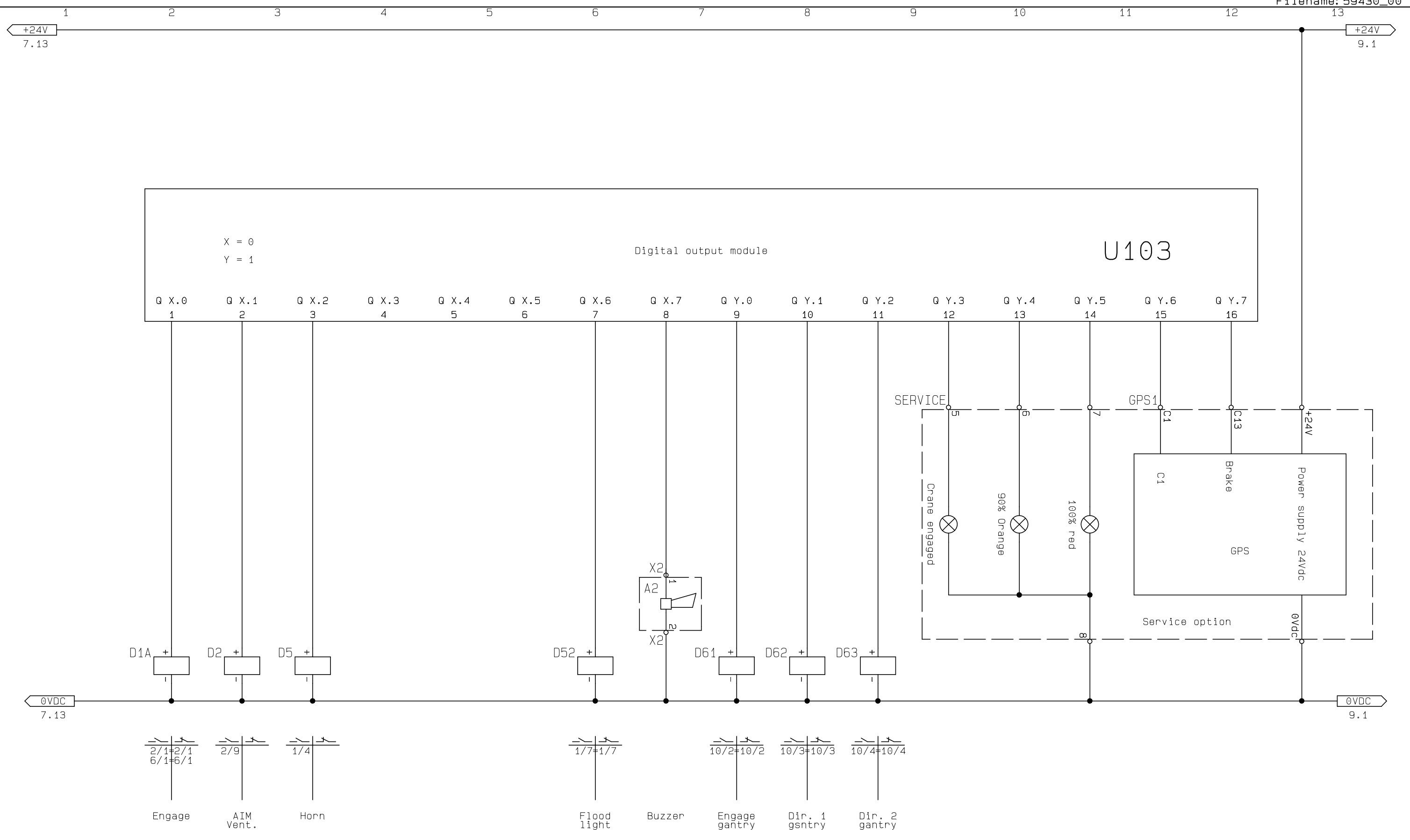



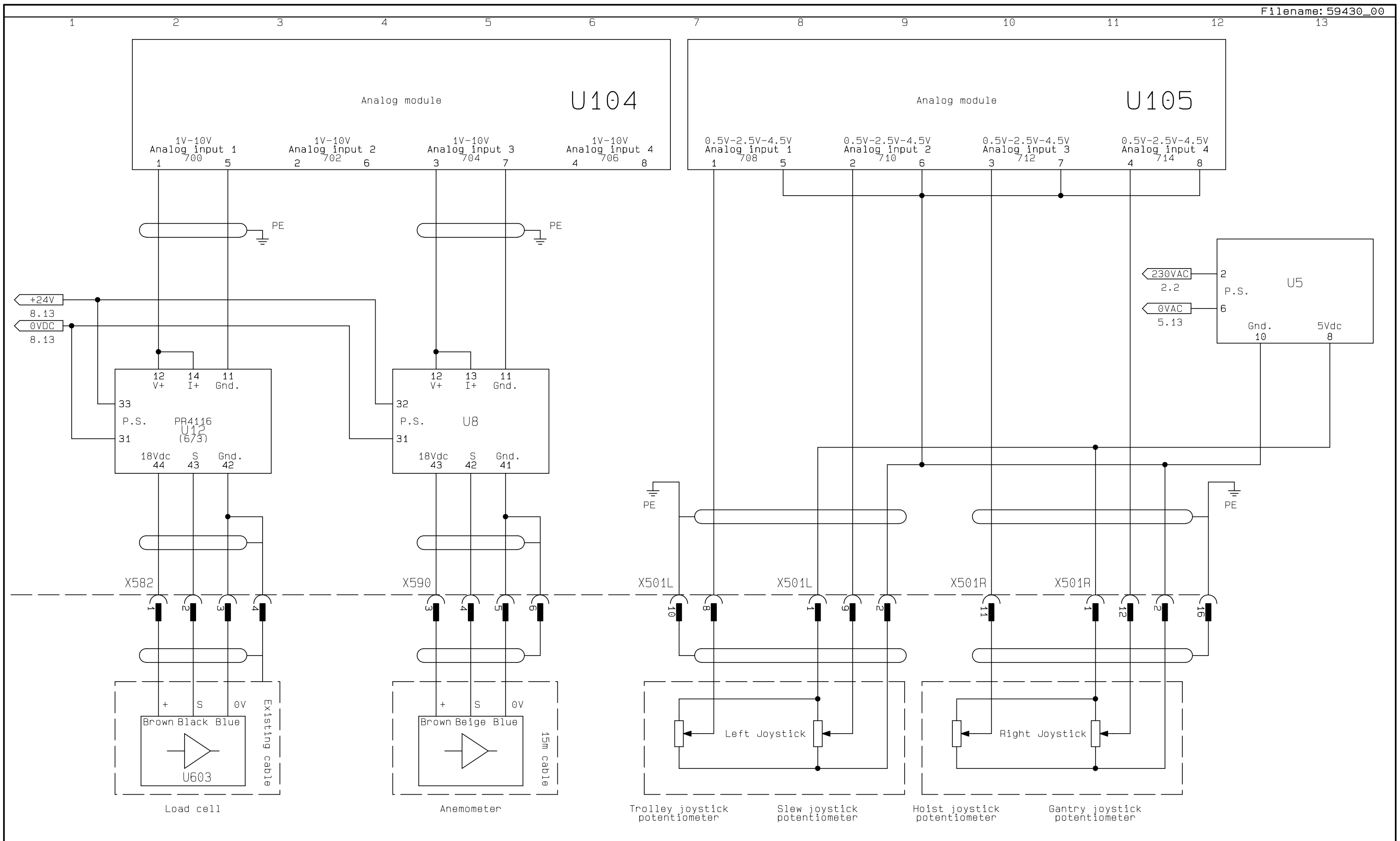

1 2 3 4 5 6 7 8 9 10 11 12 13

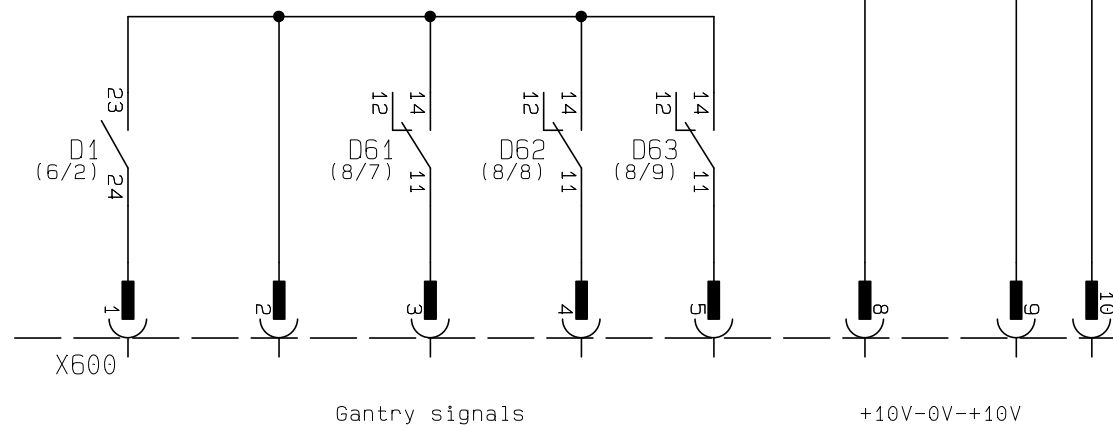
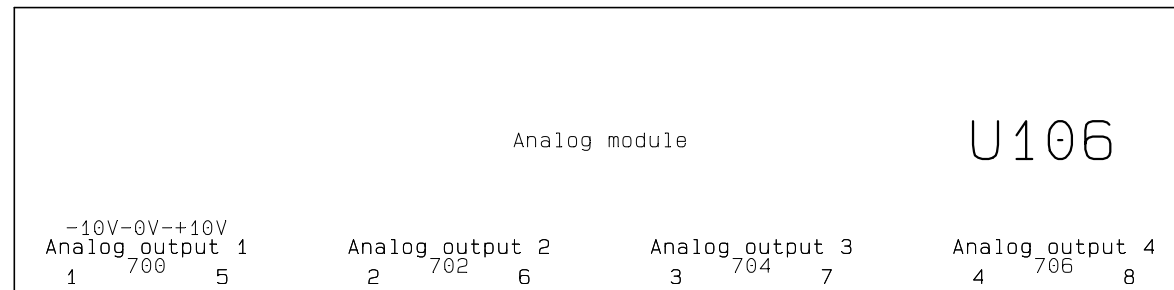

1 2 3 4 5 6 7 8 9 10 11 12 13

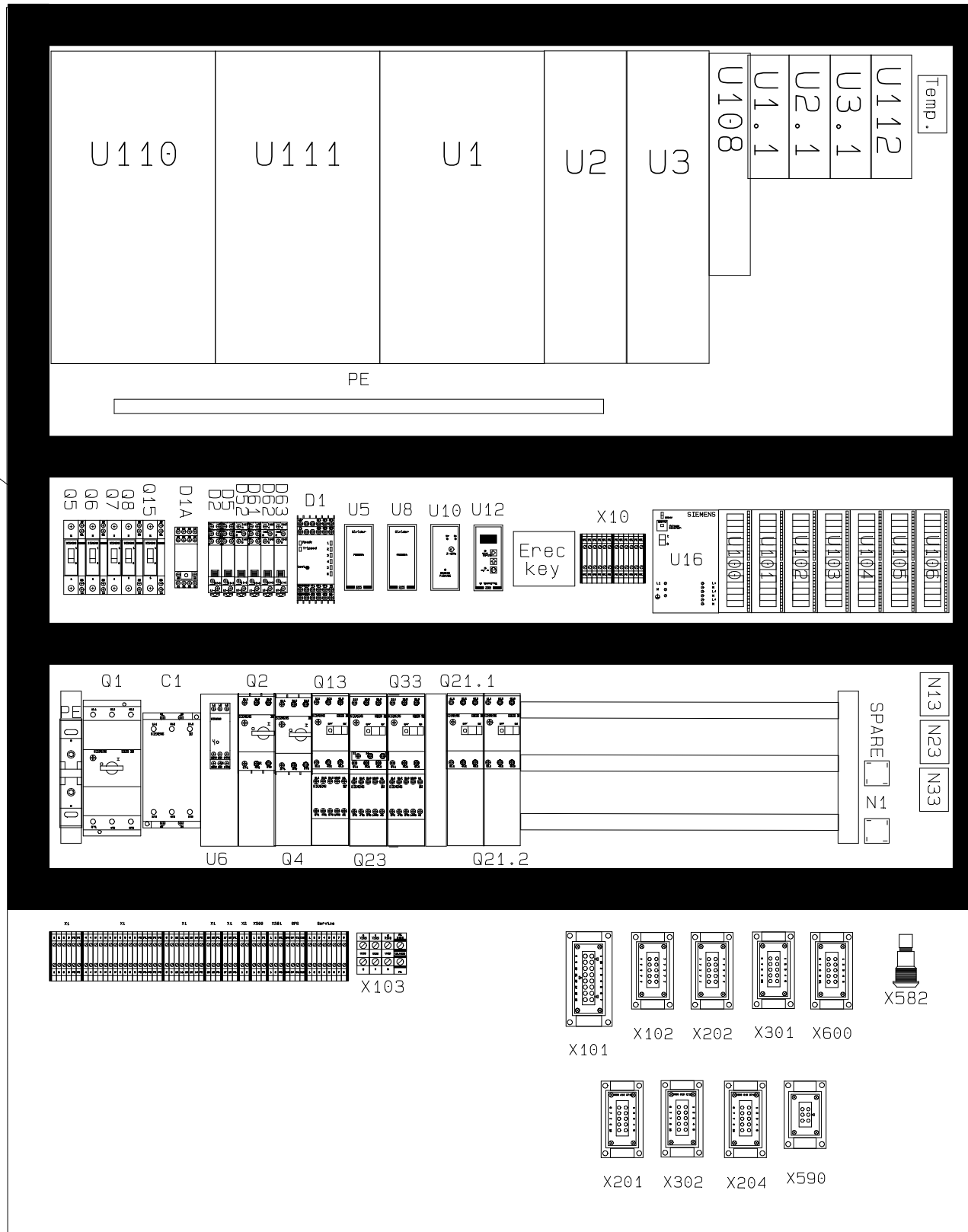

400 & 230VAC

24VDC

Klemme type: AKZ4  
 Jord klemmer: Med forbindelse til skinne  
 Leveres på to separate skinner

X1

X1

X1

X1

X1

X2

X500

X581

GPS

Service

1	2	2	3	PE	PE	4	4	N	N	N	N	N	6	6	6	6	PE	PE	PE	PE	PE	8	9	10	11	12	13	14	PE	15	16	PE	17	18	PE	1	2	1	2	PE	1	2	PE	24V	0V	C1	C13	1	2	3	4	5	6	7	8																																																																										
⊘	⊘	⊘	⊘	⊘	⊘	⊘	⊘	⊘	⊘	⊘	⊘	⊘	⊘	⊘	⊘	⊘	⊘	⊘	⊘	⊘	⊘	⊘	⊘	⊘	⊘	⊘	⊘	⊘	⊘	⊘	⊘	⊘	⊘	⊘	⊘	⊘	⊘	⊘	⊘	⊘	⊘	⊘	⊘	⊘	⊘	⊘	⊘	⊘	⊘	⊘	⊘	⊘	⊘	⊘																																																																											
⊘	⊘	⊘	⊘	⊘	⊘	⊘	⊘	⊘	⊘	⊘	⊘	⊘	⊘	⊘	⊘	⊘	⊘	⊘	⊘	⊘	⊘	⊘	⊘	⊘	⊘	⊘	⊘	⊘	⊘	⊘	⊘	⊘	⊘	⊘	⊘	⊘	⊘	⊘	⊘	⊘	⊘	⊘	⊘	⊘	⊘	⊘	⊘	⊘	⊘	⊘	⊘	⊘	⊘	⊘	⊘	⊘	⊘																																																																								
1	2	2	3	PE	PE	4	4	N	N	N	N	N	6	6	6	6	PE	PE	PE	PE	PE	8	9	10	11	12	13	14	PE	15	16	PE	17	18	PE	1	2	1	2	PE	1	2	PE	24V	0V	C1	C13	1	2	3	4	5	6	7	8																																																																										

1 2 3 4 5 6 7 8 9 10 11 12 13

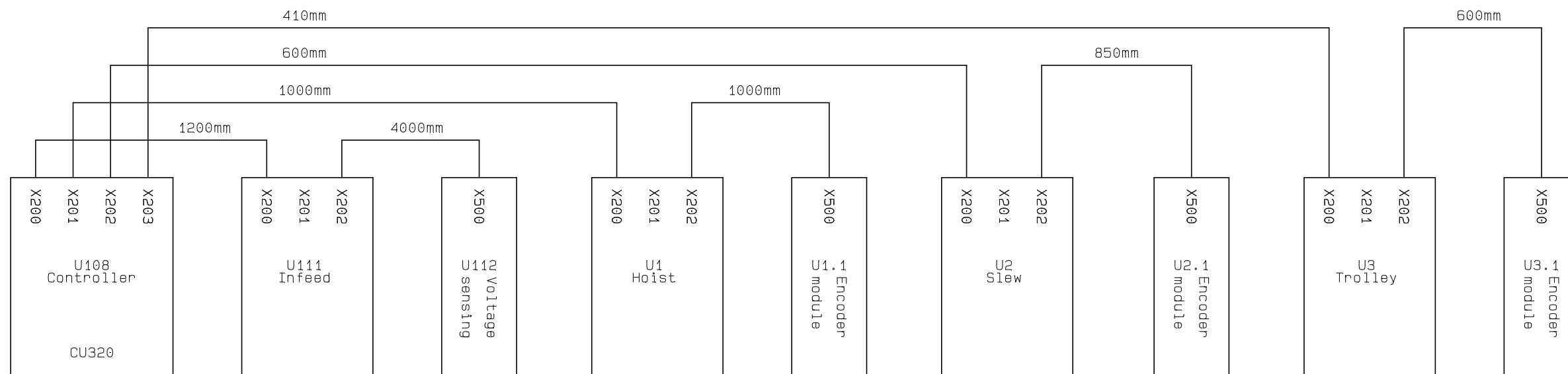

Company		Product name		
Krøll Cranes A/S		K320 1468		
BOM		Name		
48.00059430		Main Panel 42.5KW SINAMICS		
Position	Component	Item number	Product name	Quantity
000	Q1	13.13981570	MAXIMALAFBRYDER 100A 3VA1	1.0000
001		13.13681561	ADAPTER FOR BUSBAR (3VA1 100A/160A)	1.0000
002		13.13981563	TERMINAL COVER	1.0000
003		13.13981588	TERMINAL COVER LONG	1.0000
004	Q2	13.13980632	MAXIMUM CURRENT BREAKER 10A	1.0000
005		13.13680636	ADAPTER	1.0000
006	Q4	13.13980366	MAXIMUM CURRENT BREAKER 7-10A	1.0000
007		13.13680636	ADAPTER	1.0000
008		13.13980592	AUX. CONTACT	1.0000
009	Q5	13.13780596	CIRCUIT BREAKER 1P-6A	1.0000
010		13.13780593	AUX. CONTACT	1.0000
015	Q6	13.13780598	CIRCUIT BREAKER 1P-13A	1.0000
016		13.13780593	AUX. CONTACT	1.0000
017	Q7	13.13780596	CIRCUIT BREAKER 1P-6A	1.0000
018	Q8	13.13780597	CIRCUIT BREAKER 1P-10A	1.0000
019		13.13780593	AUX. CONTACT	1.0000
020	C1	13.13880610	CONTACTOR	1.0000
021		13.13880686	AUX. BLOCK	1.0000
022		13.13680998	ADAPTOR	1.0000
023	Q13+C13	13.13481251	LINKED MODULE 0.7-1A	1.0000
024		13.13980592	AUX. CONTACT	1.0000
025	Q15	13.13780596	CIRCUIT BREAKER 1P-6A	1.0000
026		13.13780593	AUX. CONTACT	1.0000
027	Q21.1	13.13980495	MAXIMUM CURRENT BREAKER 14-20A	1.0000
028		13.13980592	AUX. CONTACT	1.0000
029		13.13681193	ADAPTER	1.0000
030	Q21.2	13.13980495	MAXIMUM CURRENT BREAKER 14-20A	1.0000
031		13.13980592	AUX. CONTACT	1.0000
032		13.13681193	ADAPTER	1.0000
033	Q23+C23	13.13481252	LINKED MODULE 1.1-1.6A	1.0000
034		13.13880621	AUX BLOCK	1.0000
035		13.13980592	AUX. CONTACT	1.0000
036	Q33+C33	13.13481252	LINKED MODULE 1.1-1.6A	1.0000
037		13.13980592	AUX. CONTACT	1.0000
038	D1	13.13881581	SAFETY RELAY	1.0000
039	D1A	13.21981211	RELAY 24VDC	1.0000
040	D2	13.22080565	AUX. RELAY 24VDC	1.0000
045		13.22080564	RELAY SOCKET	1.0000
046	D5	13.22080663	RELAY 24VDC 2P	1.0000
047		13.22080664	SOCKET	1.0000
048	D61	13.22080663	RELAY 24VDC 2P	1.0000
049		13.22080664	SOCKET	1.0000
050	D62	13.22080663	RELAY 24VDC 2P	1.0000
051		13.22080664	SOCKET	1.0000
052	D63	13.22080663	RELAY 24VDC 2P	1.0000
053		13.22080664	SOCKET	1.0000
054	U1	13.20581307	MOTOR MODULE 85A	1.0000
055	U1.1	13.20581313	SENSOR MODULE SMC30	1.0000
056		13.20581317	SHIELD CONTACT	1.0000
057	U3	13.20581304	MOTOR MODULE 30A	1.0000
058	U3.1	13.20581313	SENSOR MODULE SMC30	1.0000
059		13.20581317	SHIELD CONTACT	1.0000
060		13.20581323	POWER CONNECTOR FOR MOTOR MODULES 3-30A	1.0000
061	U3	13.20581304	MOTOR MODULE 30A	1.0000
062	U3.1	13.20581313	SENSOR MODULE SMC30	1.0000
063		13.20581317	SHIELD CONTACT	1.0000
064		13.20581323	POWER CONNECTOR FOR MOTOR MODULES 3-30A	1.0000
065	U5	14.38280054	POWER SUPPLY 2x5VDC	1.0000

070		13.16580275	SOCKET	1.0000
071		14.30899400	HOLDING SPRING	1.0000
072	U6	13.13880835	PHASE FAULT RELAY	1.0000
073		13.13680636	ADAPTER	1.0000
074	U8	14.38582134	AMPLIFIER FOR ANEMOMETER	1.0000
075	U10	14.26181244	TACHO RELAY	1.0000
076		13.16580275	SOCKET	1.0000
077		14.26181470	HOLDING SPRING	1.0000
078	U12	14.38581883	ISOLATION AMPLIFIER	1.0000
079	U16	14.38281515	POWER SUPPLY 24Vdc	1.0000
080	U100	13.21981541	ET200SP CPU1510SP-1 PN	1.0000
081		13.21981555	MEMORY CARD FOR S7-1X00 4MB	1.0000
082		13.21981561	ET200SP SIMATIC BUSADAPTER 2X RJ45	1.0000
083	U101	13.21981543	ET200SP DI 16x24VDC	1.0000
084	U102	13.21981543	ET200SP DI 16x24VDC	1.0000
085	U103	13.21981546	ET200SP DO 16x24VDC 0,5A	1.0000
086	U104	13.21981548	ET200SP AI 4xU/I 2-WIRE	1.0000
087	U105	13.21981548	ET200SP AI 4xU/I 2-WIRE	1.0000
088	U106	13.21981550	ET200SP AO 4XU/1	1.0000
089		13.21981551	ET200SP-1 SOKKEL FOR I/O MODUL	5.0000
090		13.21981562	ET200SP-POWER SOKKEL FOR I/O MODUL	1.0000
095	U108	13.20581540	CONTROL UNIT CU320-2-PN	1.0000
096		13.20581315	SPACERS	1.0000
097		13.20581311	FLASH CARD	1.0000
098		13.21981554	PROFINET RJ45 PLUG 180 DEGREEE	3.0000
099		13.21980657	PROFINETKABEL U/STIK	10.0000
100	U110	13.20581292	ACTIVE INTERFACE MODULE 55kW	1.0000
101	U111	13.20581297	ACTIVE LINE MODULE 55kW	1.0000
102	U112	13.20581316	VOLTAGE SENSING MODULE VSM10	1.0000
103	HEAT	13.20881083	HEATER	1.0000
104	T2	14.12381818	THERMOSTAT	1.0000
105	N1	13.18100409	RECTIFIER	2.0000
106	N13	13.18180877	BRAKE RECTIFIER 400VAC-180VDC	1.0000
107	N23	13.18181456	RECTIFIER, 440V/3A	1.0000
108	N33	13.18180877	BRAKE RECTIFIER 400VAC-180VDC	1.0000
109	BUZZER	14.29181200	BUZZER	1.0000
110	BUSBAR	13.13680638	RAIL	3.0000
111		13.13680639	HOLDER	3.0000
112		13.13680640	COVER	2.0000
113		13.13680941	COVER	1.0000
114	PE	14.16880957	BRACKET	2.0000
115		14.16880834	EARTH RAIL	0.5000
116		14.16880835	EARTH CONNECTOR	15.0000
117		14.16880836	EARTH CONNECTOR	10.0000
118	24VDC	14.16582041	WAGO 2-ETAGES KLEMMER 2,5MM2 (4MM2) G/G	10.0000
119		14.16582055	TERMINAL CONDUCTOR INTERMEDIATEPLATE	1.0000
120		14.16582063	WAGO 10-WAY JUMPER 2,5MM2	2.0000
125		14.16582057	WAGO End stop	2.0000
126	CONNECTORS	14.16582032	CONNECTOR FOR 4 CONDUCTOR GREY	25.0000
127		14.16582033	CONNECTOR FOR 4 CONDUCTOR BLUE	6.0000
128		14.16582034	CONNECTOR FOR 4 CONDUCTOR EARTH	10.0000
129		14.16582054	WAGO 4-Conductor terminal block 2,5MM2 Intermediate plate	5.0000
130		14.16582063	WAGO 10-WAY JUMPER 2,5MM2	2.0000
131		14.16582057	WAGO End stop	2.0000
132		13.15516703	BRACKET	2.0000
133	X101	14.23101107	BASE HOUSING 16POL	1.0000
134		14.23181199	FEMALE PLUG 16POL	1.0000
135		14.23180792	CODING PINS	2.0000
136	X102	14.23101106	BASE HOUSING 10POL	1.0000
137		14.23181197	FEMALE PLUG 10POL	1.0000
138		14.23180792	CODING PINS	2.0000
139	X103	14.16582029	CONNECTOR FOR 2 CONDUCTOR GREY	3.0000
140		14.16582031	CONNECTOR FOR 2 CONDUCTOR EARTH	1.0000
141	X201	14.23101106	BASE HOUSING 10POL	1.0000

142		14.23181197	FEMALE PLUG 10POL	1.0000
143		14.23180792	CODING PINS	1.0000
144	X202	14.23101106	BASE HOUSING 10POL	1.0000
145		14.23181197	FEMALE PLUG 10POL	1.0000
146		14.23180792	CODING PINS	2.0000
147	X210	14.23101106	BASE HOUSING 10POL	1.0000
148		14.23181197	FEMALE PLUG 10POL	1.0000
149		14.23180792	CODING PINS	2.0000
150	X301	14.23101106	BASE HOUSING 10POL	1.0000
155		14.23181197	FEMALE PLUG 10POL	1.0000
156		14.23180792	CODING PINS	2.0000
157	X302	14.23101107	BASE HOUSING 16POL	1.0000
158		14.23181199	FEMALE PLUG 16POL	1.0000
159		14.23180792	CODING PINS	2.0000
160	X501R	14.23101107	BASE HOUSING 16POL	1.0000
161		14.23181199	FEMALE PLUG 16POL	1.0000
162		14.23180792	CODING PINS	1.0000
163	X501L	14.23101106	BASE HOUSING 10POL	1.0000
164		14.23181197	FEMALE PLUG 10POL	1.0000
165		14.23180792	CODING PINS	1.0000
166	X581	14.23181645	BASE HOUSING 4POL	1.0000
167		14.23181643	FEMALE PLUG 4-POL	1.0000
168	X582	14.23181645	BASE HOUSING 4POL	1.0000
169		14.23181643	FEMALE PLUG 4-POL	1.0000
170	X590	14.23180767	BASE HOUSING 6POL	1.0000
171		14.23181195	FEMALE PLUG 6POL	1.0000
172		14.23180792	CODING PINS	1.0000
173	X600	14.23101106	BASE HOUSING 10POL	1.0000
174		14.23181196	MALE PLUG 10POL	1.0000
175		14.23180792	CODING PINS	1.0000
176		13.21481239	PANEL	1.0000
177		13.21481414	TOP MOUNT	1.0000
178		13.21481415	SIDEE PANELS	1.0000
179		13.21481069	LAMP w/PLUG	1.0000
180	KEY	14.12681889	HOLDER	1.0000
181	SWITCH	14.12681534	NO CONTACT	1.0000
185		14.12681842	KEY SWITCH	1.0000



1 2 3 4 5 6 7 8 9 10 11 12 13

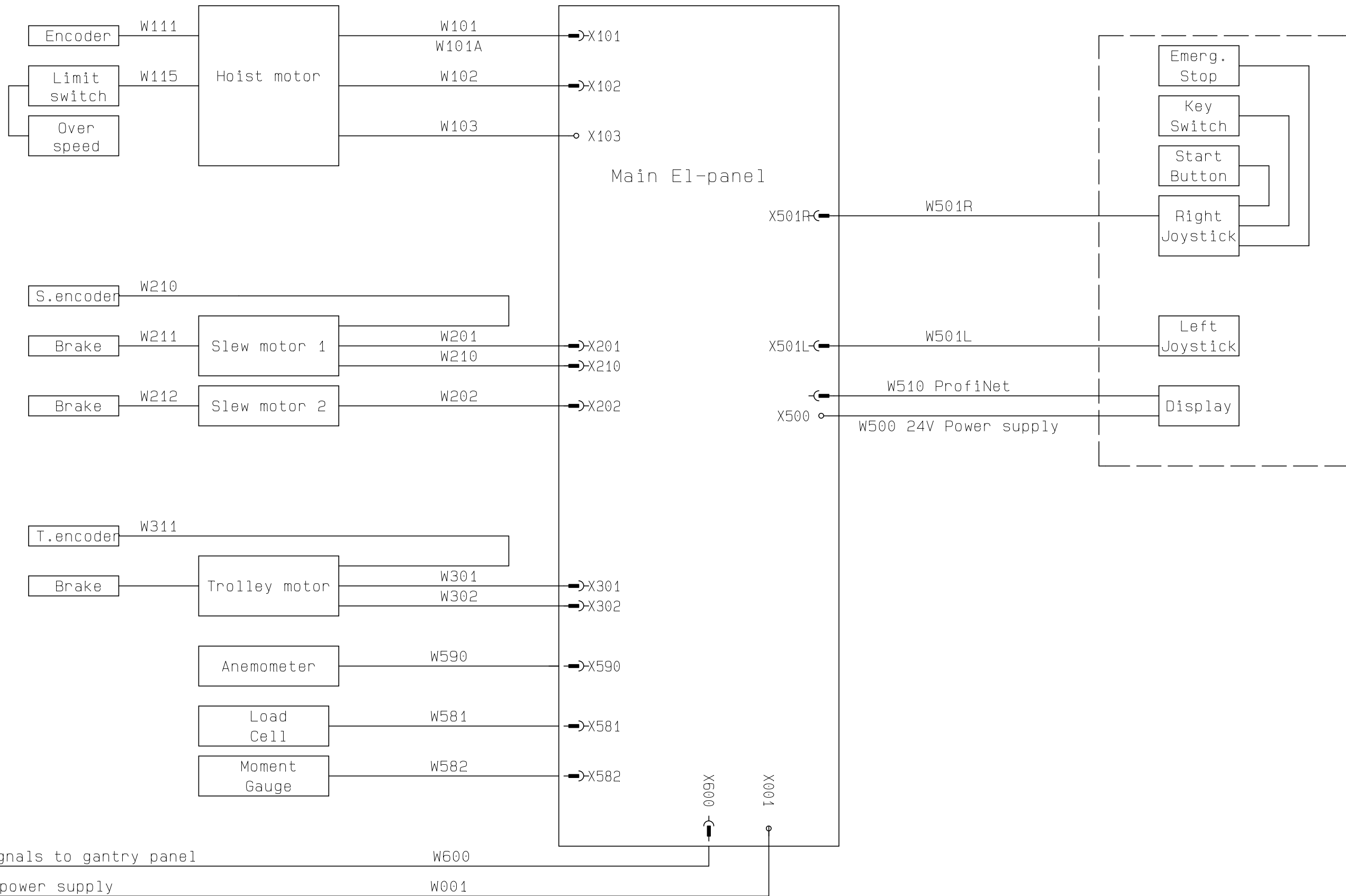

OPTION: Signals to gantry panel

Incomming power supply



**Krøll Cranes A/S**  
 Nordkranvej 2, 3540 Lyngby  
 Tlf. +45 48 18 74 00  
 Fax. +45 48 18 88 07  
 www.krollcranes.com

Project title: Wiring K320  
 Pagetitle: Wiring top crane

Drawn: JBN

Drawing no.: 48.00059431

Rev.: 00

Last prt.: 02-02-2018

14:12

Order no.:

Last changed: 20-06-2016

10:31

Page 1

of 1

<b>Company</b>		<b>Product name</b>		
Krøll Cranes A/S		K320 1468		
<b>BOM</b>		<b>Name</b>		
48.00059431		Wiring hoist, slew, trolley, miscellaneous		
<b>Position</b>	<b>Component</b>	<b>Item number</b>	<b>Product name</b>	<b>Quantity</b>
100	X101	14.23101103	PLUG HOUSING 16POL	1.0000
101		14.23181198	MALE PLUG 16POL	1.0000
102		14.23180792	CODING PINS	2.0000
103		14.30081322	CABLE GLAND M20	1.0000
104	W101	14.18380782	CABLE 12x0.75mm2+S	25.0000
105	W101A	14.18381940	CABLE 4X2X0.5mm2	25.0000
106	X102	14.23101102	PLUG HOUSING 10POL	1.0000
107		14.23181196	MALE PLUG 10POL	1.0000
108		14.23180792	CODING PINS	2.0000
109	W102	14.18381209	CABLE 12 G1.5mm2	25.0000
110	W103	14.18381928	EMC MOTOR CABLE 3X16+3G2.5MM2	25.0000
111	W111	14.18381940	CABLE 4X2X0.5mm2	2.0000
112	W115	14.17381425	CABEL 4 x 0.5+S	6.0000
120	HOIST	15.00050916	AC-MOTOR 42.5/65kW	1.0000
200	X201	14.23101102	PLUG HOUSING 10POL	1.0000
201		14.23181196	MALE PLUG 10POL	1.0000
203		14.23180792	CODING PINS	2.0000
204		14.30081322	CABLE GLAND M20	1.0000
205	W201	14.18381209	CABLE 12 G1.5mm2	6.0000
206	X202	14.23101102	PLUG HOUSING 10POL	1.0000
207		14.23181196	MALE PLUG 10POL	1.0000
208		14.23180792	CODING PINS	2.0000
209		14.30081322	CABLE GLAND M20	1.0000
210	W202	14.18381209	CABLE 12 G1.5mm2	7.0000
211	X210	14.23101102	PLUG HOUSING 10POL	1.0000
212		14.23181196	MALE PLUG 10POL	1.0000
213		14.23180792	CODING PINS	2.0000
214		14.30081322	CABLE GLAND M20	1.0000
215	W210	14.18381940	CABLE 4X2X0.5mm2	8.0000
216	W210A	14.18381940	CABLE 4X2X0.5mm2	1.0000
217	W211	14.17181253	CABLE 3x1.5mm2	2.0000
218	W212	14.17181253	CABLE 3x1.5mm2	2.0000
220	SLEW	15.00050889	SLEW MOTOR	1.0000
221	MOTORS	15.00050890	SLEW MOTOR	1.0000
300	X301	14.23101102	PLUG HOUSING 10POL	1.0000
301		14.23181196	MALE PLUG 10POL	1.0000
302		14.23180792	CODING PINS	2.0000
303		14.30081322	CABLE GLAND M20	1.0000
304	W301	14.18381940	CABLE 4X2X0.5mm2	14.0000
305	X302	14.23101102	PLUG HOUSING 10POL	1.0000
306		14.23181196	MALE PLUG 10POL	1.0000
307		14.23180792	CODING PINS	2.0000
308		14.30081322	CABLE GLAND M20	1.0000
309	W302	14.18381209	CABLE 12 G1.5mm2	14.0000
320	TROLLEY	15.00050992	TROLLEY MOTOR	1.0000
500	LOAD CELL	13.15181269	LOAD PIN 10T 4-20mA	1.0000
502	X582	14.23181644	PLUG HOUSING 4-POL	1.0000
503		14.23181642	MALE PLUG 4-POL	1.0000
504		14.23181881	PLUG COVER	1.0000
505	X590	14.23180684	PLUG HOUSING 6POL	1.0000
506		14.23180686	PLUG	1.0000

Company		Product name		
Krøll Cranes A/S		K320 1468		
BOM		Name		
48.00059432		WIRING DRIVERS CABIN		
Position	Component	Item number	Product name	Quantity
001	JOYSTICKS	14.21582042	JOYSTICK HALL SENSOR	2.0000
002		14.00059256	FRONT PLATE FOR JOYSTICK	1.0000
003		14.16582060	WAGO 7-POL HUN STIK TIL JOYSTICK	3.0000
004		14.16582061	WAGO 7-POL HAN STIK TIL JOYSTICK	3.0000
005		14.16582062	WAGO 7-POL KABEL AFLASTNING STIK TIL JOYSTICK	6.0000
009	DISPLAY	13.21981473	DISPLAY	1.0000
010	X410	13.21981552	PROFINET RJ45 PLUG 90 DEGREEE	1.0000
011	W500	14.18381504	CABEL 3G1.5mm2	10.0000
012	W510	13.21980657	PROFINETKABEL U/STIK	10.0000
013	X501L	14.23101102	PLUG HOUSING 10POL	1.0000
014		14.23181196	MALE PLUG 10POL	1.0000
015		14.23180792	CODING PINS	2.0000
016	W501L	14.18380782	CABLE 12x0.75mm2+S	10.0000
017	X501R	14.23101103	PLUG HOUSING 16POL	1.0000
018		14.23181198	MALE PLUG 16POL	1.0000
019		14.23180792	CODING PINS	1.0000
020	W501R	14.18381473	CABEL 18G0.75mm2	1.0000
025		46.00080031	CRANE NAME PLATE	1.0000
027	W520	14.00000201	CABLE 3G1.5mm2	5.0000
028		64.00059428	VENTILATIONSHÆTTE UDVEDIG H=200x1000	1.0000

## 3.1 Overview of faults and alarms

### 3.1.1 General information about faults and alarms

#### Displaying faults/alarms

If a fault occurs, the drive indicates the fault and/or alarm.

The following methods for displaying faults and alarms are available:

- Display via the fault and alarm buffer with PROFIBUS.
- Display online via the commissioning software.

#### Differences between faults and alarms

The differences between faults and alarms are as follows:

Table 3-1 Differences between faults and alarms

Type	Description
<p>Faults</p>	<p>What happens when a fault occurs?</p> <ul style="list-style-type: none"> <li>• The appropriate fault reaction is triggered.</li> <li>• Status signal ZSW1.3 is set.</li> <li>• The fault is entered in the fault buffer.</li> </ul> <p>How are faults eliminated?</p> <ul style="list-style-type: none"> <li>• Remove the original cause of the fault.</li> <li>• Acknowledge the fault.</li> </ul>
<p>Alarms</p>	<p>What happens when an alarm occurs?</p> <ul style="list-style-type: none"> <li>• Status signal ZSW1.7 is set.</li> <li>• The alarm is entered in the alarm buffer.</li> </ul> <p>How are alarms eliminated?</p> <ul style="list-style-type: none"> <li>• Alarms acknowledge themselves. If the cause of the alarm is no longer present, then they automatically reset themselves.</li> </ul>

**Fault responses**

The following fault responses are defined:

Table 3-2 Fault responses

List	PROFI-drive	Reaction	Description
NONE	-	None	No response when a fault occurs.
OFF1	ON/ OFF	Brake along the ramp generator deceleration ramp followed by pulse disable	<p><b>Closed-loop speed control (p1300 = 20, 21)</b></p> <ul style="list-style-type: none"> <li>• n_set = 0 is input immediately to brake the drive along the deceleration ramp (p1121).</li> <li>• When zero speed is detected, the motor holding brake (if parameterized) is closed (p1215). The pulses are suppressed when the brake application time (p1217) expires.</li> </ul> <p>Zero speed is detected if the actual speed drops below the threshold in p1226 or if the monitoring time (p1227) started when speed setpoint &lt;= speed threshold (p1226) has expired.</p> <p><b>Closed-loop torque control (p1300 = 23)</b></p> <ul style="list-style-type: none"> <li>• The following applies to closed-loop torque control mode: Reaction as for OFF2.</li> <li>• When changing over to closed-loop control using p1501, the following applies: There is no dedicated braking response. If the actual speed drops below the speed threshold (p1226), or the timer stage (p1277) has expired, the motor holding brake (if parameterized) is closed. The pulses are suppressed when the brake application time (p1217) expires.</li> </ul>
OFF2	COAST STOP	Internal/external pulse disable	<p><b>Closed-loop speed and torque control</b></p> <ul style="list-style-type: none"> <li>• Instantaneous pulse suppression, the drive "coasts" to a standstill.</li> <li>• The motor holding brake (if one is being used) is closed immediately.</li> <li>• Power-on disable is activated.</li> </ul>

Table 3-2 Fault responses, continued

List	PROFI-drive	Reaction	Description
OFF3	QUICK STOP	Brake along the OFF3 deceleration ramp followed by pulse disable	<p><b>Closed-loop speed control (p1300 = 20, 21)</b></p> <ul style="list-style-type: none"> <li>n_set=0 is input immediately to brake the drive along the OFF3 deceleration ramp (p1135).</li> <li>When zero speed is detected, the motor holding brake (if parameterized) is closed. The pulses are suppressed when the brake application time (p1217) expires.</li> </ul> <p>Zero speed is detected if the actual speed drops below the threshold in p1226 or if the monitoring time (p1227) started when speed setpoint &lt;= speed threshold (p1226) has expired.</p> <ul style="list-style-type: none"> <li>Power-on disable is activated.</li> </ul> <p><b>Closed-loop torque control (p1300 = 23)</b></p> <ul style="list-style-type: none"> <li>Switchover to speed-controlled operation and other reactions as described for speed-controlled operation.</li> </ul>
STOP1	-	-	In preparation
STOP2	-	n_set = 0	<ul style="list-style-type: none"> <li>n_set=0 is input immediately to brake the drive along the OFF3 deceleration ramp (p1135).</li> <li>The drive remains in closed-loop speed control mode.</li> </ul>
DCBRAKE	-	-	In preparation
ENCODER	-	Internal/external pulse disable (p0491)	<p>The fault reaction ENCODER is applied as a function of the setting in p0491.</p> <p>Factory setting: p0491 = 0 --&gt; Encoder fault causes OFF2</p>

### Acknowledgement of faults

The list of faults and alarms specifies how to acknowledge each fault after the cause has been remedied.

Table 3-3 Acknowledgement of faults

Acknowledgement	Description
POWER ON	<p>The fault is acknowledged by a POWER ON process (switch drive unit off and on again).</p> <p><b>Note:</b> If this action has not eliminated the fault cause, the fault is displayed again immediately after power up.</p>
IMMEDIATELY	<p>Faults can be acknowledged at an individual drive object (Points 1 to 3) or at all drive objects (point 4) as follows:</p> <p>1 Acknowledge by setting parameter: p3981 = 0 --&gt; 1</p> <p>2 Acknowledge via binector inputs:</p> <p>p2103 BI: 1. Acknowledge faults p2104 BI: 2. Acknowledge faults p2105 BI: 3. Acknowledge faults</p> <p>3 Acknowledge using PROFIBUS control signal: STW1.7 = 0 --&gt; 1 (edge)</p> <p>4 Acknowledging all faults p2102 BI: Acknowledging all faults</p> <p>All of the faults at all of the drive objects of the drive system can be acknowledged using this binector input.</p> <p><b>Note:</b></p> <ul style="list-style-type: none"> <li>• These faults can also be acknowledged by a POWER ON operation.</li> <li>• If this action has not eliminated the fault cause, the fault is displayed again immediately after power up.</li> <li>• Safety Integrated faults The "Safe Stop" (SH) function must be deselected before these faults are acknowledged.</li> </ul>
PULSE INHIBIT	<p>The fault can only be acknowledged when the pulses are inhibited (r0899.11 = 0). To acknowledge, the same possibilities exist as described under IMMEDIATE acknowledgement.</p>

### Save fault buffer on POWER OFF

The contents of the fault buffer are saved to non-volatile storage when the Control Unit 320 (CU320) is powered down, i.e. the fault buffer history is still available when the unit is powered up again.

---

#### Note:

Prerequisites:

- Firmware with version V2.2 or later.
- Control Unit 320 (CU320) with hardware version C or higher.  
The hardware version is shown on the rating plate or can be displayed online with the commissioning software (in Project Navigator under "Drive Unit" --> Configuration --> Version Overview).

If these conditions are not fulfilled, the contents of the fault buffer are deleted on every POWER ON.

---

The fault buffer of a drive object comprises the following parameters:

- r0945[0...63], r0947[0...63], r0948[0...63], r0949[0...63]
- r2109[0...63], r2130[0...63], r2133[0...63], r2136[0...63]

The fault buffer contents can be deleted manually as follows:

- Delete fault buffer for all drive objects:  
p2147 = 1 --> p2147 = 0 is automatically set after execution.
- Delete fault buffer for a specific drive object:  
p0952 = 0 --> The parameter belongs to the specified drive object.

The fault buffer contents are automatically deleted in response to the following events:

- Restore factory setting (p0009 = 30 and p0976 = 1).
- Download with modified structure (e.g. number of drive objects changed).
- Power-up after other parameter values have been loaded (e.g. p0976 = 10).
- Firmware release upgrade.



### 3.1.2 Explanation of the list of faults and alarms

The data in the following example has been chosen at random. A description can contain the information listed below. Some of the information is optional.

The list of faults and alarms (see Section 3.2) has the following layout:

----- **Start of example** -----

---

<b>Axxxxx (F, N)</b>	<b>Fault location (optional): Name</b>
Reaction:	NONE
Acknowledgement:	NONE
Cause:	Description of possible causes. Fault value (r0949, interpret format): or alarm value (r2124, interpret format): (optional) Information about fault or alarm values (optional).
Remedy:	Description of possible remedies.
Reaction to F:	A_INFEED: OFF2 (OFF1, NONE) SERVO: NONE (OFF1, OFF2, OFF3) VECTOR: NONE (OFF1, OFF2, OFF3)
Acknowledgement for F:	IMMEDIATELY (POWER ON)
Reaction to N:	NONE
Acknowledgement for N:	NONE

- Axxxxx** Alarm xxxxx
- Axxxxx (F, N)** Alarm xxxxx (message type can be changed to F or N)
- Fxxxxx** Fault xxxxx
- Fxxxxx (A, N)** Fault xxxxx (report type can be changed to A or N)
- Nxxxxx** No message
- Nxxxxx (A)** No message (message type can be changed to A)
- Cxxxxx** Safety message (separate message buffer)

A report comprises a letter followed by the relevant number.

The meaning of the letters is as follows:

- A means "Alarm"
- F means "Fault"
- N means "No Report" or "Internal Report"
- C means "Safety message"

The optional brackets indicate whether the type specified for this report can be changed and which report types can be adjusted via parameter (p2118, p2119).

Information about reaction and acknowledgement are specified independently for a report with adjustable report type (e.g. reaction to F, acknowledgement for F).

---

**Note:**

You can change the default properties of a fault or alarm by setting parameters.

References: //IH1/ SINAMICS S120 Installation and Start-Up Manual  
"Diagnosis" section

The list of faults and alarms (see Section 3.2) provide information referred to the properties of a message/report that have been set as standard. If the properties of a specific message/report are changed, then the appropriate information may have to be modified in this list.

---

**Fault location (optional): Name**

The fault location (optional), the name of the fault or alarm and the report number all serve to identify the report (e.g. with the commissioning software).

**Reaction: Default fault reaction (adjustable fault reaction)**

Specifies the default reaction in the event of a fault.

The optional brackets indicate whether the default fault reaction can be changed and which fault reactions can be adjusted via parameter (p2100, p2101).

**Note:**

See Subsection 3.1.1

**Acknowledgement: Default acknowledgement (adjustable acknowledgement)**

Specifies the default method of fault acknowledgement after the cause has been eliminated.

The optional brackets indicate whether the default acknowledgement can be changed and which acknowledgement can be adjusted via parameter (p2126, p2127).

**Note:**

See Subsection 3.1.1

**Cause:**

Description of the possible causes of the fault/alarm A fault or alarm value is also specified as an option.

Fault value (r0949, format):

The fault value is entered in the fault buffer in r0949[0...63] and specifies additional, precise information about a fault.

Alarm value (r2124, format):

The alarm value specifies additional, precise information about an alarm.

The alarm value is entered in the alarm buffer in r2124[0...7] and specifies additional, precise information about an alarm.

**Remedy:**

Description of the potential methods for eliminating the cause of the active fault or alarm.



**Warning**

In individual cases, the servicing and maintenance personnel are responsible for choosing a suitable method for eliminating the cause of faults.

---

### 3.1.3 Numerical ranges of faults and alarms

Faults and alarms are organized into the following numerical ranges:

Table 3-4 Numerical ranges of faults and alarms

<b>from</b>	<b>to</b>	<b>Section</b>
1000	2999	Control Unit
3000	4999	Reserved
5000	5999	Power unit
6000	6999	Infeed
7000	7999	Drives
8000	8999	Option Board
9000	29999	Reserved
30000	30999	DRIVE-CLiQ component power section
31000	31999	DRIVE-CLiQ component encoder 1
32000	32999	DRIVE-CLiQ component encoder 2
33000	33999	DRIVE-CLiQ component encoder 3
34000	34999	Reserved
35000	35999	Terminal Module 31 (TM31)
36000	49999	Reserved
50000	50399	Communication Board (COMM BOARD)
50400	65535	Reserved

## 3.2 List of faults and alarms

Product: SINAMICS S, Version: 2402300, Language: eng

---

**F01000 Internal software error**  
**Reaction:** OFF2  
**Acknowledge:** POWER ON  
**Cause:** An internal software error has occurred.  
Fault value (r0949, interpret hexadecimal):  
Only for internal Siemens troubleshooting.  
**Remedy:**  
- carry-out a POWER ON (power off/on) for all components.  
- upgrade the firmware release.  
- contact the Hotline.  
- replace the Control Unit.

---

**F01001 Internal software error**  
**Reaction:** OFF2  
**Acknowledge:** POWER ON  
**Cause:** An internal software error has occurred.  
Fault value (r0949, interpret hexadecimal):  
Only for internal Siemens troubleshooting.  
**Remedy:**  
- carry-out a POWER ON (power off/on) for all components.  
- upgrade the firmware release.  
- contact the Hotline.

---

**F01002 Internal software error**  
**Reaction:** OFF2  
**Acknowledge:** POWER ON  
**Cause:** An internal software error has occurred.  
Fault value (r0949, interpret hexadecimal):  
Only for internal Siemens troubleshooting.  
**Remedy:**  
- carry-out a POWER ON (power off/on) for all components.  
- upgrade the firmware release.  
- contact the Hotline.

---

**F01003 Acknowledgment delay when accessing the memory**  
**Reaction:** OFF2  
**Acknowledge:** POWER ON  
**Cause:** A memory area was accessed that does not return a "READY".  
Fault value (r0949, interpret hexadecimal):  
Only for internal Siemens troubleshooting.  
**Remedy:**  
- carry-out a POWER ON (power off/on) for all components.  
- contact the Hotline.

<b>F01005</b>	<b>Firmware download DRIVE-CLiQ component unsuccessful</b>
<b>Reaction:</b>	NONE
<b>Acknowledge:</b>	IMMEDIATELY
<b>Cause:</b>	Firmware was not able to be downloaded into a DRIVE-CLiQ component. Fault value (r0949): xxyyyy hex: xx = component number, yyyy = cause of the fault. Cause of the fault (decimal): 011: DRIVE-CLiQ component has detected a checksum error. 015: The selected DRIVE-CLiQ component did not accept the contents of the firmware file. 101: After several communication attempts, not response from the DRIVE-CLiQ component. 140: Firmware file for the DRIVE-CLiQ component not available on the CompactFlash card. 143: Component is not changed in the firmware download mode. 156: Component with the specified component number is not available (p7828). Additional values: Only for internal Siemens troubleshooting.
<b>Remedy:</b>	<ul style="list-style-type: none"> <li>- check the selected component number (p7828).</li> <li>- check the DRIVE-CLiQ connection.</li> <li>- save suitable firmware file for download in the directory /siemens/sinamics/code/sac/.</li> <li>- after POWER ON has been carried-out again for the DRIVE-CLiQ component, download the firmware again.</li> </ul>
<b>A01006</b>	<b>Firmware update DRIVE-CLiQ component required</b>
<b>Reaction:</b>	NONE
<b>Acknowledge:</b>	NONE
<b>Cause:</b>	The firmware of a DRIVE CLiQ component must be updated as there is no suitable firmware or firmware version in the component for operation with the Control Unit. Alarm value (r2124, decimal): Component number of the DRIVE-CLiQ component.
<b>Remedy:</b>	Firmware update using the commissioning software: The firmware version of all of the components on the "version overview" page can be read in the Project Navigator under "Configuration" of the associated drive unit and an appropriate firmware update can be carried-out. Firmware update via parameter: <ul style="list-style-type: none"> <li>- take the component number from the alarm value and enter into p7828.</li> <li>- start the firmware download with p7829 = 1.</li> </ul>
<b>A01007</b>	<b>POWER ON DRIVE-CLiQ component required</b>
<b>Reaction:</b>	NONE
<b>Acknowledge:</b>	NONE
<b>Cause:</b>	A DRIVE-CLiQ component must be powered-up again (POWER ON) as, for example, the firmware was updated. Alarm value (r2124, decimal): Component number of the DRIVE-CLiQ component.
<b>Remedy:</b>	Switch-out the power supply of the specified DRIVE-CLiQ component and switch-in again.
<b>F01010</b>	<b>Drive type unknown</b>
<b>Reaction:</b>	NONE
<b>Acknowledge:</b>	IMMEDIATELY
<b>Cause:</b>	An unknown drive type was found. Fault value (r0949, decimal): Drive object type (refer to p0101, p0107).
<b>Remedy:</b>	<ul style="list-style-type: none"> <li>- carry-out a POWER ON (power off/on) for all components.</li> <li>- upgrade the firmware release.</li> <li>- contact the Hotline.</li> </ul>

---

**F01015 Internal software error**

**Reaction:** OFF2  
**Acknowledge:** POWER ON  
**Cause:** An internal software error has occurred.  
Fault value (r0949, decimal):  
Only for internal Siemens troubleshooting.  
**Remedy:** - carry-out a POWER ON (power off/on) for all components.  
- upgrade the firmware release.  
- contact the Hotline.

---

**A01016 (F) CompactFlash card changed**

**Reaction:** NONE  
**Acknowledge:** NONE  
**Cause:** On the CompactFlash card, at least one file in the directory /SIEMENS/SINAMICS/ has been illegally changed with respect to that supplied from the factory. No changes are permitted in this directory.  
Alarm value (r2124, decimal):  
0: Checksum of one file is incorrect.  
1: File missing.  
2: Too many files.  
3: Incorrect firmware version.  
4: Incorrect checksum of the back-up file.  
See also: r9925 (CompactFlash card file error)  
**Remedy:** For the CompactFlash card, restore the status when originally supplied from the factory.  
Note:  
The file involved can be read-out using parameter r9925.  
See also: r9926 (CompactFlash card check status)  
Reaction upon F: OFF2  
Acknowledge upon F: POWER ON

---

**A01017 Component lists changed**

**Reaction:** NONE  
**Acknowledge:** NONE  
**Cause:** On the CompactFlash card, one file in the directory /SIEMENS/SINAMICS/DATA or /ADDON/SINAMICS/DATA has been illegally changed with respect to that supplied from the factory. No changes are permitted in this directory.  
Alarm value (r2124, decimal):  
The problem is indicated in the first digit of the alarm value:  
1: File does not exist.  
2: Firmware version of the file does not match-up with the software version.  
3: The file checksum is incorrect.  
The second digit of the alarm value indicates in which directory the file is located:  
0: Directory /SIEMENS/SINAMICS/DATA/  
1: Directory /ADDON/SINAMICS/DATA/  
The third digit of the alarm value indicates the file:  
0: File MOTARM.ACX  
1: File MOTSRM.ACX  
2: File MOTSLM.ACX  
3: File ENCDATA.ACX  
4: File FILTDATA.ACX  
5: File BRKDATA.ACX  
**Remedy:** For the CompactFlash card file involved, restore the status when originally supplied from the factory.

<b>F01030</b>	<b>Monitoring, master control: Sign of life failure PC</b>
<b>Reaction:</b>	OFF1
<b>Acknowledge:</b>	IMMEDIATELY
<b>Cause:</b>	For active PC master control, no sign-of-life was received within the monitoring time. The master control was returned to the active BICO interconnection.
<b>Remedy:</b>	Set the monitoring time higher at the PC/AOP or disable completely. Notice: The monitoring time should be set as short as possible. A long monitoring time means a late response when the communications fail! The monitoring time is set in milliseconds. - in the AOP using the Main menu -> Settings -> Control settings -> Timeout monitoring - In STARTER using <Drive> -> Commissioning -> Control panel -> Button "Fetch master control" -> a window is displayed in which the monitoring time can be set.
<b>F01033</b>	<b>Units changeover: Reference parameter value invalid</b>
<b>Reaction:</b>	NONE
<b>Acknowledge:</b>	IMMEDIATELY
<b>Cause:</b>	When changing over the units into the referred representation type, it is not permissible that any of the reference parameters required are equal to 0.0 Fault value (r0949, parameter): Reference parameter, whose value is 0.0. See also: p0349 (Selects system of units, motor equivalent circuit diagram data), p0505 (Selecting the system of units), p0595 (Selecting technological units)
<b>Remedy:</b>	Set the value of the reference parameter to a number different than 0.0. See also: p0304 (Rated motor voltage), p0305 (Rated motor current), p0310 (Rated motor frequency), p0596 (Reference quantity, technological units), p2000 (Reference frequency), p2001 (Reference voltage), p2002 (Reference current), p2003 (Reference torque), r2004 (Reference power)
<b>F01034</b>	<b>Units changeover: Calculation parameter values after reference value change unsuccessful</b>
<b>Reaction:</b>	NONE
<b>Acknowledge:</b>	IMMEDIATELY
<b>Cause:</b>	The change of a reference parameter meant that for a parameter involved, the selected value was not able to be recalculated in the per unit notation. The change was rejected, the original parameter values were restored. Fault value (r0949, parameter): Parameter, whose value was not able to be re-calculated. See also: p0304 (Rated motor voltage), p0305 (Rated motor current), p0310 (Rated motor frequency), p0596 (Reference quantity, technological units), p2000 (Reference frequency), p2001 (Reference voltage), p2002 (Reference current), p2003 (Reference torque), r2004 (Reference power)
<b>Remedy:</b>	Select the value of the reference parameters so that the parameter involved can be calculated in the per unit notation. See also: p0304 (Rated motor voltage), p0305 (Rated motor current), p0310 (Rated motor frequency), p0596 (Reference quantity, technological units), p2000 (Reference frequency), p2001 (Reference voltage), p2002 (Reference current), p2003 (Reference torque), r2004 (Reference power)
<b>A01035 (F)</b>	<b>ACX: Boot from the back-up parameter back-up files</b>
<b>Reaction:</b>	NONE
<b>Acknowledge:</b>	NONE
<b>Cause:</b>	When the Control Unit booted, no complete data set was found from the parameter back-up files. The last time that the parameterization was saved, it was not completely carried-out. Instead, a back-up data set or a back-up parameter back-up file is downloaded. Alarm value (r2124, interpret hexadecimal): Only for internal Siemens troubleshooting.
<b>Remedy:</b>	If you saved the project in the commissioning software, download your project again and save using the function "Copy RAM to ROM" or with p0977 = 1. This means that all of the parameter files are again completely written into the CompactFlash card.



Reaction upon F: A\_INFEED: NONE (OFF2)  
 SERVO: NONE (OFF1, OFF2, OFF3)  
 VECTOR: NONE (OFF1, OFF2, OFF3)

Acknowledge upon F: IMMEDIATELY

---

**F01036 (A) ACX: Parameter back-up file missing**

**Reaction:** A\_INFEED: NONE (OFF2)  
 SERVO: NONE (OFF1, OFF2, OFF3)  
 VECTOR: NONE (OFF1, OFF2, OFF3)

**Acknowledge:** IMMEDIATELY

**Cause:** When downloading the device parameterization, a parameter back-up file associated with a drive object cannot be found. Neither a PSxxxxxyy.ACX, a PSxxxxxyy.NEW nor a PSxxxxxyy.BAK parameter back-up file exists on the CompactFlash card for this drive object.  
 Fault value (r0949, interpret hexadecimal):  
 Byte 1: yyy in the file name PSxxxxxyy.ACX  
 yyy = 000 --> consistency back-up file  
 yyy = 001 ... 062 --> drive object number  
 yyy = 099 --> PROFIBUS parameter back-up file  
 Byte 2, 3, 4:  
 Only for internal Siemens troubleshooting.

**Remedy:** If you have saved your project data using the commissioning software, carry-out a new download for your project. Save using the function "Copy RAM to ROM" or with p0977 = 1 so that all of the parameter files are again completely written into the CompactFlash card.  
 If you have not saved the project data, then the system must be again commissioned for the first time.

Reaction upon A: NONE  
 Acknowledge upon A: NONE

---

**F01037 (A) ACX: Re-naming the parameter back-up file not successful**

**Reaction:** A\_INFEED: NONE (OFF2)  
 SERVO: NONE (OFF1, OFF2, OFF3)  
 VECTOR: NONE (OFF1, OFF2, OFF3)

**Acknowledge:** IMMEDIATELY

**Cause:** The re-naming after saving a parameter back-up file on the CompactFlash card or in the volatile memory was unsuccessful.  
 One of the parameter back-up files to be re-named had the "read only" attribute. The parameter back-up files are saved on the CompactFlash card in the directory \USER\SINAMICS\DATA.  
 It is possible that the CompactFlash card is defective.  
 Fault value (r0949, interpret hexadecimal):  
 Byte1: yyy in file names PSxxxxxyy.\* or CAxxxxxyy.\* or CCxxxxxyy.\*  
 yyy = 000 --> consistency back-up file  
 yyy = 099 --> PROFIBUS parameter back-up file PSxxx099.\*  
 Byte 2: xxx in the file name PSxxxxxyy.\*  
 xxx = 000 --> data save started with p0977 = 1  
 xxx = 010 --> data save started with p0977 = 10  
 xxx = 011 --> data save started with p0977 = 11  
 xxx = 012 --> data save started with p0977 = 12  
 Byte 4, 3:  
 Only for internal Siemens troubleshooting.

**Remedy:** - check whether one of the files to be overwritten has the attribute "read only" and change this file attribute into "writable". Check all of the files (PSxxxxxyy.\*, CCxxxxxyy.\*, CAxxxxxyy.\*) that belong to drive yyy designated in the fault value.  
 - replace the CompactFlash card.

Reaction upon A: NONE  
 Acknowledge upon A: NONE

---

**F01038 (A) ACX: Loading the parameter back-up file not successful**

**Reaction:** A\_INFEED: NONE (OFF2)  
SERVO: NONE (OFF1, OFF2, OFF3)  
VECTOR: NONE (OFF1, OFF2, OFF3)

**Acknowledge:** IMMEDIATELY

**Cause:** An error occurred when loading PSxxxxxyy.ACX or PTxxxxyy.ACX files from the CompactFlash card or from the volatile memory of the Control Unit.  
Fault value (r0949, interpret hexadecimal):  
Byte 1: yyy in the file name PSxxxxyy.ACX  
yyy = 000 --> consistency back-up file  
yyy = 001 ... 062 --> drive object number  
yyy = 099 --> PROFIBUS parameter back-up file  
Byte 4, 3, 2:  
Only for internal Siemens troubleshooting.

**Remedy:** - if you have saved your project data using the commissioning software, carry-out a new download for your project. Save using the function "Copy RAM to ROM" or with p0977 = 1 so that all of the parameter files are again completely written into the CompactFlash card.  
- replace the CompactFlash card.

Reaction upon A: NONE  
Acknowledge upon A: NONE

---

**F01039 (A) ACX: Writing to the parameter back-up file was unsuccessful**

**Reaction:** A\_INFEED: NONE (OFF2)  
SERVO: NONE (OFF1, OFF2, OFF3)  
VECTOR: NONE (OFF1, OFF2, OFF3)

**Acknowledge:** IMMEDIATELY

**Cause:** Writing to at least one parameter-back-up file PSxxxxyy.NEW on the CompactFlash card was unsuccessful.  
- on the CompactFlash card in the directory /USER/SINAMICS/DATA/ at least one parameter back-up file has the "read only" file attribute and cannot be overwritten.  
- there is not sufficient free memory space on the CompactFlash card.  
- the CompactFlash card is defective and cannot be written to.  
Fault value (r0949, interpret hexadecimal):  
Byte 1: yyy in the file name PSxxxxyy.NEW  
yyy = 000 --> consistency back-up file  
yyy = 001 ... 062 --> drive object number  
yyy = 099 --> PROFIBUS parameter back-up file  
Byte 2: xxx in the file name PSxxxxyy.NEW  
xxx = 000 --> data save started with p0977 = 1  
xxx = 010 --> data save started with p0977 = 10  
xxx = 011 --> data save started with p0977 = 11  
xxx = 012 --> data save started with p0977 = 12  
Byte 4, 3:  
Only for internal Siemens troubleshooting.

**Remedy:** - check the file attribute of the files (PSxxxxyy.\*, CAxxxxyy.\*, CCxxxxyy.\*) and, if required, change from "read only" to "writeable".  
- check the free memory space on the CompactFlash card. Approx. 40 kbyte of free memory space is required for every drive object in the system.  
- replace the CompactFlash card.

Reaction upon A: NONE  
Acknowledge upon A: NONE

---

<b>F01040</b>	<b>Save parameter settings and carry-out a POWER ON</b>
<b>Reaction:</b>	OFF2
<b>Acknowledge:</b>	POWER ON
<b>Cause:</b>	A parameter was changed in the drive system that means that it is necessary to save the parameters and re-boot (e.g. p0110).
<b>Remedy:</b>	- save the parameters (p0971/p0977). - carry-out a POWER ON (power off/on) for all components.
<b>F01041</b>	<b>Parameter save necessary</b>
<b>Reaction:</b>	NONE
<b>Acknowledge:</b>	IMMEDIATELY
<b>Cause:</b>	Defective or missing files were detected on the CompactFlash card when booting. Fault value (r0949, decimal): -1: Source file cannot be opened. -2: Source file cannot be read. -3: Target directory cannot be set-up. -4: Target file cannot be set-up/opened. -5: Target file cannot be written into. Additional values: Only for internal Siemens troubleshooting.
<b>Remedy:</b>	- save the parameters (p0977). - download the project again into the drive unit.
<b>F01042</b>	<b>Parameter error during project download</b>
<b>Reaction:</b>	A_INFEED: OFF2 (NONE, OFF1) SERVO: OFF2 (NONE, OFF1, OFF3) VECTOR: OFF2 (NONE, OFF1, OFF3)
<b>Acknowledge:</b>	IMMEDIATELY
<b>Cause:</b>	An error was detected when downloading a project using the commissioning (start-up) software (e.g. incorrect parameter value). For the specified parameter, it was detected that dynamic limits were exceeded that could possibly depend on other parameters. Fault value (r0949, decimal): Low word: Parameter number (16 bits without sign) Byte 3: Parameter index Byte 4: Error ID 0: Parameter number illegal. 1: Parameter value cannot be changed. 2: Lower or upper value limit exceeded. 3: Sub-index incorrect. 4: No array, no sub-index. 5: Data type incorrect. 6: Setting not permitted (only resetting). 7: Descriptive element cannot be changed. 9: Descriptive data not available. 11: No master control. 15: No text array present. 17: Task cannot be executed due to operating status. 20: Illegal value. 21: Response too long. 22: Parameter address illegal. 23: Format illegal. 24: Number of values not consistent. 25: Drive object does not exist. 101: Presently de-activated. 104: Illegal value. 107: Write access not permitted when controller enabled. 108: Units unknown. 109: Write access only in the commissioning state, encoder (p0010 = 4).

- 110: Write access only in the commissioning state, motor (p0010 = 3).
- 111: Write access only in the commissioning state, power unit (p0010 = 2).
- 112: Write access only in the quick commissioning mode (p0010 = 1).
- 113: Write access only in the ready mode (p0010 = 0).
- 114: Write access only in the commissioning state, parameter reset (p0010 = 30).
- 115: Write access only in the Safety Integrated commissioning state (p0010 = 95).
- 116: Write access only in the commissioning state, technological application/units (p0010 = 5).
- 117: Write access only in the commissioning state (p0010 not equal to 0).
- 118: Write access only in the commissioning state, download (p0010 = 29).
- 119: Parameter may not be written into in download.
- 120: Write access only in the commissioning state – drive basis configuration (device: p0009 = 3).
- 121: Write access only in the commissioning state – define drive type (device: p0009 = 2).
- 122: Write access only in the commissioning state – data set basis configuration (device: p0009 = 4).
- 123: Write access only in the commissioning state – device configuration (device: p0009 = 1).
- 124: Write access only in the commissioning state – device download (device: p0009 = 29).
- 125: Write access only in the commissioning state – device parameter reset (device: p0009 = 30).
- 126: Write access only in the commissioning state – device ready (device: p0009 = 0).
- 127: Write access only in the commissioning state – device (device: p0009 not equal to 0).
- 129: Parameter may not be written into in download.
- 130: Transfer of the master control is inhibited via BI: p0806.
- 131: Required BICO interconnection not possible, because BICO output does not supply floating value
- 132: Free BICO interconnection inhibited via p0922.
- 133: Access method not defined.
- 200: Below the valid values.
- 201: Above the valid values.
- 202: Cannot be accessed from the Basic Operator Panel (BOP).
- 203: Cannot be read from the Basic Operator Panel (BOP).
- 204: Write access not permitted.

**Remedy:** - enter the correct value into the specified parameter.  
 - identify the parameter that narrows (restricts) the limits of the specified parameter.

---

**F01043 Fatal error when downloading a project**

**Reaction:** A\_INFEED: OFF2 (OFF1)  
 SERVO: OFF2 (OFF1, OFF3)  
 VECTOR: OFF2 (OFF1, OFF3)

**Acknowledge:** IMMEDIATELY

**Cause:** A fatal error was detected when downloading a project using the commissioning (start-up) software.  
 Fault value (r0949, decimal):  
 1: Device status cannot be changed to Device Download (drive object ON?).  
 2: Drive object ID incorrect  
 3: A drive object that has already been deleted is deleted again.  
 4: Deletes drive object that has already been registered for generation.  
 5: Deletes a drive object that no longer exists.  
 6: Generating an undeleted drive object that already existed.  
 7: Regeneration of a drive object already registered for generation.  
 8: Maximum number of drive objects that can be generated exceeded.  
 9: Error while generating a device drive object.  
 10: Error while generating target topology parameters (p9902 and p9903).  
 11: Error when generating a drive object (global component).  
 12: Error when generating a drive object (drive component).  
 13: Unknown drive object type.  
 14: Drive status cannot be changed to Ready (p0947 and p0949).  
 15: Drive status cannot be changed to Drive Download.  
 16: Device status cannot be changed to Ready.  
 17: It is not possible to download the topology. The component wiring should be checked, taking into account the various messages/signals.  
 18: A new download is only possible if the factory settings are re-established for the drive unit.  
 19: The slot for the option module has been configured several times (e.g. CAN and COMM BOARD)  
 20: The configuration is inconsistent (e.g. CAN for Control Unit, however no CAN configured for drive objects - Active Line Module, servo or vector).

**Remedy:**

- use the actual version of the commissioning software.
- modify the offline project and carry-out a new download (e.g. compare the number of drive objects, motor, encoder, power unit in the offline project and at the drive).
- change the drive system (is a drive rotating or is there a message/signal?).
- carefully note any other messages/signals and remove their cause.

**F01044 CU CompactFlash: Message incorrectly written**

**Reaction:** OFF2  
**Acknowledge:** POWER ON  
**Cause:** An error was detected when loading the message descriptions (FDxxxxxy.ACX) saved on the CompactFlash card. Fault value (r0949, interpret hexadecimal):  
 Only for internal Siemens troubleshooting.  
**Remedy:** Replace the CompactFlash card.

**A01045 CU CompactFlash: Configuring data invalid**

**Reaction:** NONE  
**Acknowledge:** NONE  
**Cause:** An invalid data type was detected when evaluating parameter files PSxxxxxy.ACX, PTxxxxxy.ACX, CAxxxxxy.ACX or CCxxxxxy.ACX, saved on the CompactFlash card. Alarm value (r2124, interpret hexadecimal):  
 Only for internal Siemens troubleshooting.  
**Remedy:** Restore the factory setting using (p0976 = 1) and re-load the project into the drive unit. Operation without any restrictions is then possible.  
 After downloading the project, save the parameterization in STARTER using the function "Copy RAM to ROM" or with p0977 = 1. This means that the incorrect parameter files are overwritten on the CompactFlash card.

**A01046 (F) CU CompactFlash: Configuring data invalid**

**Reaction:** NONE  
**Acknowledge:** NONE  
**Cause:** An invalid data type was detected when evaluating the parameter files PSxxxxxy.ACX, PTxxxxxy.ACX, CAxxxx-xy.ACX or CCxxxxxy.ACX saved on the CompactFlash card. Alarm value (r2124, interpret hexadecimal):  
 Only for internal Siemens troubleshooting.  
**Remedy:** Restore the factory setting using (p0976 = 1) and re-load the project into the drive unit. Operation without any restrictions is then possible.  
 After downloading the project, save the parameterization in STARTER using the function "Copy RAM to ROM" or with p0977 = 1 so that the incorrect parameter files are overwritten on the CompactFlash card.  
 Reaction upon F: A\_INFEED: NONE (OFF2)  
 SERVO: NONE (OFF1, OFF2, OFF3)  
 VECTOR: NONE (OFF1, OFF2, OFF3)  
 Acknowledge upon F: IMMEDIATELY

**A01047 (F) ACX: Write to parameter error**

**Reaction:** NONE  
**Acknowledge:** NONE  
**Cause:** When evaluating the parameters files PSxxxxxy.ACX, PTxxxxxy.ACX, CAxxxxxy.ACX or CCxxxxxy.ACX, saved on the CompactFlash card, a parameter value was not able to be transferred into the Control Unit memory. Alarm value (r2124, interpret hexadecimal):  
 Only for internal Siemens troubleshooting.  
**Remedy:** Restore the factory setting using (p0976 = 1) and re-load the project into the drive unit. Operation without any restrictions is then possible.  
 After downloading the project, save the parameterization in STARTER using the function "Copy RAM to ROM" or with p0977 = 1. This means that the incorrect parameter files are overwritten on the CompactFlash card.  
 Reaction upon F: A\_INFEED: NONE (OFF2)  
 SERVO: NONE (OFF1, OFF2, OFF3)  
 VECTOR: NONE (OFF1, OFF2, OFF3)  
 Acknowledge upon F: IMMEDIATELY

<b>A01049</b>	<b>CU CompactFlash: It is not possible write to file</b>
<b>Reaction:</b>	NONE
<b>Acknowledge:</b>	NONE
<b>Cause:</b>	It is not possible to write into a write-protective file (PSxxxxx.acx). The write request was interrupted. Alarm value (r2124, decimal): Drive object number.
<b>Remedy:</b>	Check whether the write-protected attribute has been set for the files on the CompactFlash card under .../USER/SINAMICS/DATA/... When required, remove write protection and save again (e.g. set p0971 to 1).
<b>F01050</b>	<b>CompactFlash card and device not compatible</b>
<b>Reaction:</b>	A_INFEED: OFF2 (NONE, OFF1) SERVO: OFF2 (NONE, OFF1, OFF3) VECTOR: OFF2 (NONE, OFF1, OFF3)
<b>Acknowledge:</b>	IMMEDIATELY
<b>Cause:</b>	The CompactFlash card and the device type do not match (e.g. a CompactFlash card for SINAMICS S is inserted in SINAMICS G).
<b>Remedy:</b>	- insert the matching CompactFlash card - use the matching Control Unit or power unit.
<b>F01051</b>	<b>Drive object type is not available</b>
<b>Reaction:</b>	NONE
<b>Acknowledge:</b>	IMMEDIATELY
<b>Cause:</b>	The drive object type in conjunction with the selected application-specific perspective is not available. The required descriptive file (PDxxxxyy.ACX) does not exist on the CompactFlash card. Fault value (r0949, decimal): Index of p0103 and p0107. See also: p0103 (Application-specific view), r0103 (Application-specific view), p0107 (Drive object type), r0107 (Drive object type)
<b>Remedy:</b>	- for this drive object type (p0107), select a valid application-specific perspective (p0103). - save the required descriptive file (PDxxxxyy.ACX) on the CompactFlash card. See also: p0103 (Application-specific view), r0103 (Application-specific view), p0107 (Drive object type), r0107 (Drive object type)
<b>A01052</b>	<b>CU: System overload calculated for the complete target topology</b>
<b>Reaction:</b>	NONE
<b>Acknowledge:</b>	NONE
<b>Cause:</b>	A system overload was calculated based on a complete active target topology. Alarm value (r2124, decimal): 2: Computation time load too high. 6: Cyclic computation time load too high.
<b>Remedy:</b>	- reduce the sampling time. - only use one data set (CDS, DDS). - de-activate the function module. - de-activate the drive object. - remove the drive object from the target topology. Note: After executing the appropriate counter-measure, a new calculation must be initiated with p9974 = 1.
<b>A01053</b>	<b>CU: System overload measured</b>
<b>Reaction:</b>	NONE
<b>Acknowledge:</b>	NONE
<b>Cause:</b>	A system overload was determined based on measured values. Alarm value (r2124, decimal): 2: Computation time load too high. 6: Cyclic computation time load too high. See also: r9976 (System load)

**Remedy:**

- reduce the sampling time.
- only use one data set (CDS, DDS).
- de-activate the function module.
- de-activate the drive object.
- remove the drive object from the target topology.

---

**A01054      Parameter save necessary**

**Reaction:**            NONE  
**Acknowledge:**      NONE  
**Cause:**  
**Remedy:**

---

**A01064      Parameter save necessary**

**Reaction:**            NONE  
**Acknowledge:**      NONE  
**Cause:**  
**Remedy:**

---

**A01065      Drive: Error, inactive encoder**

**Reaction:**            NONE  
**Acknowledge:**      NONE  
**Cause:**              On or several inactive encoders indicate an error.  
**Remedy:**             Remove the error for the inactive encoder.

---

**A01099      Tolerance window of the timer synchronization exited**

**Reaction:**            NONE  
**Acknowledge:**      NONE  
**Cause:**              The clock (time) master exited the selected tolerance window for clock synchronization.  
                             See also: p3109 (RTC real time synchronization, tolerance window)  
**Remedy:**             Select the re-synchronization interval so that the synchronization deviation between the clock master and drive system lies within the tolerance window.  
                             See also: r3108 (RTC last synchronization deviation)

---

**A01100      CU: CompactFlash card withdrawn**

**Reaction:**            NONE  
**Acknowledge:**      NONE  
**Cause:**              The CompactFlash card (non-volatile memory) was withdrawn in operation.  
                             Notice:  
                             It is not permissible that the CompactFlash card is withdrawn or inserted under voltage.  
**Remedy:**             - power-down the drive system.  
                             - re-insert the CompactFlash card that was withdrawn - this card must match the drive system.  
                             - power-up the drive system again.

---

**F01105 (A)    CU: Insufficient memory**

**Reaction:**            OFF1  
**Acknowledge:**      IMMEDIATELY (POWER ON)  
**Cause:**              Two many functions, data sets or drives configured on this Control Unit.  
                             Fault value (r0949, decimal):  
                             Only for internal Siemens troubleshooting.  
**Remedy:**             - change the configuration on this Control Unit.  
                             - use an additional Control Unit.  
**Reaction upon A:**    NONE  
**Acknowledge upon A:** NONE

<b>F01107</b>	<b>CU: Save to CompactFlash card unsuccessful</b>
<b>Reaction:</b>	NONE
<b>Acknowledge:</b>	IMMEDIATELY
<b>Cause:</b>	A data save on the CompactFlash card was not able to be successfully carried-out. - CompactFlash card is defective. - CompactFlash card does not have sufficient memory space. Fault value (r0949, decimal): -1: The file on the RAM was not able to be opened. -2: The file on the RAM was not able to be read. -3: A new directory was not able to be set-up on the CompactFlash card. -4: A new file was not able to be set-up on the CompactFlash card. -5: A new file was not able to be written onto the CompactFlash card.
<b>Remedy:</b>	- try to save again. - use another CompactFlash card.
<b>F01110</b>	<b>CU: More than one SINAMICS G on one Control Unit</b>
<b>Reaction:</b>	NONE
<b>Acknowledge:</b>	IMMEDIATELY
<b>Cause:</b>	More than one SINAMICS G power unit type is being operated from the Control Unit. Fault value (r0949, decimal): Number of the second drive with a SINAMICS G power unit type.
<b>Remedy:</b>	Only one SINAMICS G drive type is permitted.
<b>F01111</b>	<b>CU: SINAMICS S and G together on one Control Unit</b>
<b>Reaction:</b>	NONE
<b>Acknowledge:</b>	IMMEDIATELY
<b>Cause:</b>	SINAMICS S and G drive units are being operated together on one Control Unit. Fault value (r0949, decimal): Number of the first drive object with a different power unit type.
<b>Remedy:</b>	Only power units of one particular drive type may be operated with one CU.
<b>F01112</b>	<b>CU: Power unit not permissible</b>
<b>Reaction:</b>	NONE
<b>Acknowledge:</b>	IMMEDIATELY
<b>Cause:</b>	The connected power unit cannot be used together with this Control Unit. Fault value (r0949, decimal): 1: Power unit is not supported (e.g. PM240). 2: DC/AC power unit connected to CU310 not permissible.
<b>Remedy:</b>	Replace the power unit that is not permissible by a component that is permissible.
<b>F01120 (A)</b>	<b>Terminal initialization has failed</b>
<b>Reaction:</b>	OFF1 (OFF2)
<b>Acknowledge:</b>	IMMEDIATELY (POWER ON)
<b>Cause:</b>	An internal software error has occurred when initializing the terminal functions on the CU3xx, the TB30 or the TM31. Fault value (r0949, interpret hexadecimal): Only for internal Siemens troubleshooting.
<b>Remedy:</b>	- carry-out a POWER ON (power off/on) for all components. - upgrade the firmware release. - contact the Hotline. - replace the Control Unit.
Reaction upon A:	NONE
Acknowledge upon A:	NONE



<b>F01122 (A)</b>	<b>Frequency at the measuring probe input too high</b>
<b>Reaction:</b>	OFF1 (OFF2)
<b>Acknowledge:</b>	IMMEDIATELY
<b>Cause:</b>	The frequency of the pulses at the measuring probe input is too high. Fault value (r0949, decimal): 1: DI/DO 9 (X122.8) 2: DI/DO 10 (X122.10) 4: DI/DO 11 (X122.11) 8: DI/DO 13 (X132.8) 16: DI/DO 14 (X132.10) 32: DI/DO 15 (X132.11) 1001: DI/DO 9 (X122.8) initialization error 1002: DI/DO 10 (X122.10) initialization error 1004: DI/DO 11 (X122.11) initialization error 1008: DI/DO 13 (X132.8) initialization error 1016: DI/DO 14 (X132.10) initialization error 1032: DI/DO 15 (X132.11) initialization error
<b>Remedy:</b>	Reduce the frequency of the pulses at the measuring probe input.
Reaction upon A:	NONE
Acknowledge upon A:	NONE
<b>F01150</b>	<b>CU: Number of instances of a drive object type exceeded</b>
<b>Reaction:</b>	NONE
<b>Acknowledge:</b>	IMMEDIATELY
<b>Cause:</b>	The maximum permissible number of instances of a drive object type was exceeded. Fault value (r0949, decimal): Byte 1: Drive object type (p0107). Byte 2: Max. permissible number of instances for this drive object type. Byte 3: Actual number of instances for this drive object type.
<b>Remedy:</b>	- power-down the unit. - suitably restrict the number of instances of a drive object type by reducing the number of inserted components. - re-commission the unit.
<b>F01205</b>	<b>CU: Time slice overflow</b>
<b>Reaction:</b>	OFF2
<b>Acknowledge:</b>	POWER ON
<b>Cause:</b>	Insufficient processing time is available for the existing topology. Fault value (r0949, interpret hexadecimal): Only for internal Siemens troubleshooting.
<b>Remedy:</b>	- reduce the number of drives. - increase the sampling times.
<b>F01210</b>	<b>CU: Basic clock cycle selection and DRIVE-CLiQ clock cycles do not match</b>
<b>Reaction:</b>	NONE
<b>Acknowledge:</b>	IMMEDIATELY
<b>Cause:</b>	The parameter to select the basic clock cycle does not match the drive topology. Drives connected to the same DRIVE-CLiQ port of the Control Unit have been assigned different basic clock cycles. Fault value (r0949, decimal): The fault value specifies the parameter involved. See also: r0111 (DRIVE-CLiQ basis sampling time selection)
<b>Remedy:</b>	Only those drive objects may be connected to the same DRIVE-CLiQ socket of the Control Unit that should run with the same basic clock cycle. For example, Active Line Modules and Motor Modules should be inserted at different DRIVE-CLiQ ports as their basic clock cycles and current controller clock cycles are generally different. See also: r0111 (DRIVE-CLiQ basis sampling time selection)

<b>F01220</b>	<b>CU: Bas clk cyc too low</b>
<b>Reaction:</b>	NONE
<b>Acknowledge:</b>	IMMEDIATELY
<b>Cause:</b>	The parameter for the basic clock cycle is set too short for the number of connected drives. Fault value (r0949, decimal): The fault value specifies the parameter involved. See also: r0110 (DRIVE-CLiQ basis sampling times)
<b>Remedy:</b>	- increase the basic clock cycle. - reduce the number of connected drives and start to re-commission the unit. See also: r0110 (DRIVE-CLiQ basis sampling times)
<b>F01221</b>	<b>CU: Bas clk cyc too low</b>
<b>Reaction:</b>	NONE
<b>Acknowledge:</b>	IMMEDIATELY
<b>Cause:</b>	The closed-loop control / monitoring cannot maintain the intended clock cycle. The runtime of the closed-loop control/monitoring is too longer for the particular clock cycle or the computation time remaining in the system is not sufficient for the closed-loop control/monitoring. Fault value (r0949, interpret hexadecimal): Only for internal Siemens troubleshooting.
<b>Remedy:</b>	Increase the basic clock cycle of DRIVE-CLiQ communications. See also: p0112 (Sampling times pre-setting p0115)
<b>A01223</b>	<b>CU: Sampling time inconsistent</b>
<b>Reaction:</b>	NONE
<b>Acknowledge:</b>	NONE
<b>Cause:</b>	When changing a sampling time (p0115[0], p0799 or p4099), inconsistency between the clock cycles has been identified. Alarm value (r2124, decimal): 1: Value, low minimal value. 2: Value, high maximum value. 3: Value not a multiple of 1.25 µs. 4: Value does not match clock cycle synchronous PROFIBUS operation. 5: Value not a multiple of 125 µs. 6: Value not a multiple of 250 µs. 7: Value not a multiple of 375 µs. 8: Value not a multiple of 400 µs. 10: Special restriction of the drive object violated. 20: For a SERVO with a 62.5 µs sampling time, more than a maximum of two SERVO-type drive objects were detected on the DRIVE-CLiQ line. 21: Value is not a multiple of the current controller sampling time of a servo or vector drive that is in the system. 30: Value less than 31.25 µs. 31: Value less than 62.5 µs. 32: Value less than 125 µs. 40: Nodes (devices) have been identified on the DRIVE-CLiQ line whose highest common denominator of the sampling times is less than 125 µs. Further, none of the nodes (devices) has a sampling time of less than 125 µs. 41: A chassis unit was identified on the DRIVE-CLiQ line. Further, the highest common denominator of the sampling times of the all of the nodes (devices) connected to the line is less than 250 µs. 42: An Active Line Module was identified on the DRIVE-CLiQ line as device. Further, the highest common denominator of the sampling times of the all of the nodes (devices) connected to the line is less than 125 µs. 43: A Voltage Sensing Module (VSM) was identified on the DRIVE-CLiQ line as device. Further, the highest common denominator of the sampling times of the all of the nodes (devices) connected to the line is not equal to the current controller sampling time of the drive object of the VSM. 52: Nodes (devices) have been identified on the DRIVE-CLiQ line whose highest common denominator of the sampling times is less than 31.25 µs. 54: Nodes (devices) have been identified on the DRIVE-CLiQ line whose highest common denominator of the sampling times is less than 62.5 µs.

56: Nodes (devices) have been identified on the DRIVE-CLiQ line whose highest common denominator of the sampling times is less than 125 µs.  
 58: Nodes (devices) have been identified on the DRIVE-CLiQ line whose highest common denominator of the sampling times is less than 250 µs.  
 99: Inconsistency identified cross drive objects.  
 116: Recommended clock cycle in r0116[0...1].

**Remedy:**

- check the DRIVE-CLiQ cables.
- set a valid sampling time.

See also: p0115 (Sampling time for supplementary functions), p0799 (CU inputs/outputs, sampling time), p4099 (TB30 inputs/outputs, sampling time)

**A01224 CU: Pulse frequency inconsistent**

**Reaction:** NONE

**Acknowledge:** NONE

**Cause:** When changing the minimum pulse frequency (p0113) inconsistency between the pulse frequencies was identified.  
 Alarm value (r2124, decimal):  
 1: Value, low minimal value.  
 2: Value, high maximum value.  
 3: Resulting sampling time is not a multiple of 1.25 µs.  
 4: Value does not match clock cycle synchronous PROFIBUS operation.  
 10: Special restriction of the drive object violated.  
 99: Inconsistency identified cross drive objects.  
 116: Recommended clock cycle in r0116[0...1].

**Remedy:** Set a valid pulse frequency.  
 See also: p0113 (Pulse frequency, minimum selection)

**F01250 CU: CU-EEPROM incorrect read-only data**

**Reaction:** NONE (OFF2)

**Acknowledge:** POWER ON

**Cause:** Error when reading the read-only data of the EEPROM in the Control Unit.  
 Fault value (r0949, decimal):  
 Only for internal Siemens troubleshooting.

**Remedy:**

- carry-out a POWER ON.
- replace the Control Unit

**A01251 CU: CU-EEPROM incorrect read-write data**

**Reaction:** NONE

**Acknowledge:** NONE

**Cause:** Error when reading the read-write data of the EEPROM in the Control Unit.  
 Alarm value (r2124, decimal):  
 Only for internal Siemens troubleshooting.

**Remedy:** For alarm value r2124 < 256, the following applies:  
 - carry-out a POWER ON.  
 - replace the Control Unit.  
 For alarm value r2124 >= 256, the following applies:  
 - for the drive object with this alarm, clear the fault memory (p0952 = 0).  
 - as an alternative, clear the fault memory of all drive objects (p2147 = 1).  
 - replace the Control Unit.

**F01255 CU: Opt.module EEPROM incorrect read-only data**

**Reaction:** NONE (OFF2)

**Acknowledge:** POWER ON

**Cause:** Error when reading the read-only data of the EEPROM in the option module.  
 Fault value (r0949, decimal):  
 Only for internal Siemens troubleshooting.

**Remedy:**

- carry-out a POWER ON.
- replace the Control Unit.

<b>A01256</b>	<b>CU: Opt.module EEPROM incorrect read-write data</b>
<b>Reaction:</b>	NONE
<b>Acknowledge:</b>	NONE
<b>Cause:</b>	Error when reading the read-write data of the EEPROM in the option module. Fault value (r0949, decimal): Only for internal Siemens troubleshooting.
<b>Remedy:</b>	- carry-out a POWER ON. - replace the Control Unit.
<b>F01303</b>	<b>DRIVE-CLiQ component does not support the required function</b>
<b>Reaction:</b>	OFF2
<b>Acknowledge:</b>	IMMEDIATELY
<b>Cause:</b>	A function requested by the Control Unit is not supported by a DRIVE-CLiQ component. Fault value (r0949, decimal): 1: The component does not support the de-activation. 101: The Motor Module does not support an internal armature short-circuit. 102: The Motor Module does not support the de-activation. 201: The Encoder Module does not support actual value inversion (p0410.0 = 1) when using a Hall sensor (p0404.6 = 1) for the commutation. 202: The Encoder Module does not support parking/unparking. 203: The Encoder Module does not support the de-activation. 204: The firmware of this Terminal Module 15 (TM15) does not support the application TM15DI/DO. 205: The encoder module does not support the selected temperature evaluation (refer to r0458). 206: The firmware of this Terminal Module 41 refers to an old firmware version. In order to ensure error-free operation is absolutely necessary that the firmware is upgraded.
<b>Remedy:</b>	Upgrade the firmware of the DRIVE-CLiQ component involved. Re 205: Adapts parameter p0600 or p0601.
<b>F01305</b>	<b>Topology: Component number missing</b>
<b>Reaction:</b>	NONE
<b>Acknowledge:</b>	IMMEDIATELY
<b>Cause:</b>	The component number from the topology was not parameterized (p0121 (for power unit, refer to p0107), p0131 (for servo/vector drives, refer to p0107), p0141, p0151, p0161). Fault value (r0949, decimal): The fault value includes the particular data set number. The fault also occurs if speed encoders were configured (p0187 ... p0189), however, no component numbers exist for them. In this case, the fault value includes the drive data set number plus 100 * encoder number (e.g. 3xx, if a component number was not entered into p0141 for the third encoder (p0189)). See also: p0121 (Power unit component number), p0131 (Motor component number), p0141 (Encoder interface (Sensor Module) component number), p0142 (Encoder component number), p0151 (Voltage Sensing Module component number), p0161 (Option board, component number), p0186 (Motor Data Sets (MDS) number), p0187 (Encoder 1 encoder data set number), p0188 (Encoder 2 encoder data set number), p0189 (Encoder 3 encoder data set number)
<b>Remedy:</b>	Enter the missing component number or remove the component and restart commissioning. See also: p0121 (Power unit component number), p0131 (Motor component number), p0141 (Encoder interface (Sensor Module) component number), p0142 (Encoder component number), p0151 (Voltage Sensing Module component number), p0161 (Option board, component number), p0186 (Motor Data Sets (MDS) number), p0187 (Encoder 1 encoder data set number), p0188 (Encoder 2 encoder data set number), p0189 (Encoder 3 encoder data set number)

---

<b>A01315</b>	<b>Drive object not ready for operation</b>
<b>Reaction:</b>	NONE
<b>Acknowledge:</b>	NONE
<b>Cause:</b>	For the active drive object involved, at least one activated component is missing. Note: All other active and operational drive objects can be in the "RUN" state.
<b>Remedy:</b>	The alarm automatically disappears again with the following actions: - de-activate the drive object involved (p0105 = 0). - de-activate the components involved (p0125 = 0, p0145 = 0, p0155 = 0, p0165 = 0). - re-insert the components involved. See also: p0105 (Activate/de-activate drive object), p0125 (Activate/de-activate power unit components), p0145 (Voltage Sensing Module, activate/de-activate), p0155 (Voltage Sensing Module, activate/de-activate)

---

<b>A01316</b>	<b>Drive object inactive and again ready for operation</b>
<b>Reaction:</b>	NONE
<b>Acknowledge:</b>	NONE
<b>Cause:</b>	If, when inserting a component of the target topology, an inactive, non-operational drive object becomes operational again. The associated parameter of the component is, in this case, set to "activate" (p0125, p0145, p0155, p0165). Note: This is the only message, that is displayed for a de-activated drive object.
<b>Remedy:</b>	The alarm automatically disappears again with the following actions: - activate the drive object involved (p0105 = 1). - again withdraw the components involved. See also: p0105 (Activate/de-activate drive object)

---

<b>A01317</b>	<b>De-activated component again present</b>
<b>Reaction:</b>	NONE
<b>Acknowledge:</b>	NONE
<b>Cause:</b>	If a component of the target topology for an active drive object is inserted and the associated parameter of the component is set to "de-activate" (p0125, p0145, p0155, p0165). Note: This is the only message, that is displayed for a de-activated component.
<b>Remedy:</b>	The alarm automatically disappears again with the following actions: - activate the components involved (p0125 = 1, p0145 = 1, p0155 = 1, p0165 = 1). - again withdraw the components involved. See also: p0125 (Activate/de-activate power unit components), p0145 (Voltage Sensing Module, activate/de-activate), p0155 (Voltage Sensing Module, activate/de-activate)

---

<b>A01318</b>	<b>BICO: De-activated interconnections present</b>
<b>Reaction:</b>	NONE
<b>Acknowledge:</b>	NONE
<b>Cause:</b>	This alarm is output: If an inactive/non-operational drive object is again active/ready for operation and r9498[] or r9499[] are not empty and the connections listed in r9498[] and r9499 have actually been changed
<b>Remedy:</b>	Clear alarm: Set p9496 to 1 or 2 or de-activate DO

---

<b>A01319</b>	<b>Inserted component not initialized</b>
<b>Reaction:</b>	NONE
<b>Acknowledge:</b>	NONE
<b>Cause:</b>	The inserted component has still not been initiated, as the pulses are enabled.
<b>Remedy:</b>	Pulse inhibit

---

**A01320      Topology: Drive object number does not exist in configuration**

**Reaction:** NONE  
**Acknowledge:** NONE  
**Cause:** A drive object number is missing in p0978  
 Alarm value (r2124, decimal):  
 Index of p0101 under which the missing drive object number can be determined.  
**Remedy:** Set p0009 to 1 and change p0978:  
 Rules:  
 - p0978 must include all of the drive object numbers (p0101).  
 - it is not permissible that a drive object number is repeated.  
 - by entering a 0, the drive objects with PZD are separated from those without PZD.  
 - only 2 partial lists are permitted. After the second 0, all values must be 0.  
 - dummy drive object numbers (255) are only permitted in the first partial list.

---

**A01321      Topology: Drive object number does not exist in configuration**

**Reaction:** NONE  
**Acknowledge:** NONE  
**Cause:** p0978 contains a drive object number that does not exist.  
 Alarm value (r2124, decimal):  
 Index of p0978 under which the drive object number can be determined.  
**Remedy:** Set p0009 to 1 and change p0978:  
 Rules:  
 - p0978 must include all of the drive object numbers (p0101).  
 - it is not permissible that a drive object number is repeated.  
 - by entering a 0, the drive objects with PZD are separated from those without PZD.  
 - only 2 partial lists are permitted. After the second 0, all values must be 0.  
 - dummy drive object numbers (255) are only permitted in the first partial list.

---

**A01322      Topology: Drive object number present twice in configuration**

**Reaction:** NONE  
**Acknowledge:** NONE  
**Cause:** A drive object number is present more than once in p0978.  
 Alarm value (r2124, decimal):  
 Index of p0978 under which the involved drive object number is located.  
**Remedy:** Set p0009 to 1 and change p0978:  
 Rules:  
 - p0978 must include all of the drive object numbers (p0101).  
 - it is not permissible that a drive object number is repeated.  
 - by entering a 0, the drive objects with PZD are separated from those without PZD.  
 - only 2 partial lists are permitted. After the second 0, all values must be 0.  
 - dummy drive object numbers (255) are only permitted in the first partial list.

---

**A01323      Topology: More than two part lists set-up**

**Reaction:** NONE  
**Acknowledge:** NONE  
**Cause:** Partial lists are available more than twice in p0978. After the second 0, all must be 0.  
 Alarm value (r2124, decimal):  
 Index of p0978, under which the illegal value is located.  
**Remedy:** Set p0009 to 1 and change p0978:  
 Rules:  
 - p0978 must include all of the drive object numbers (p0101).  
 - it is not permissible that a drive object number is repeated.  
 - by entering a 0, the drive objects with PZD are separated from those without PZD.  
 - only 2 partial lists are permitted. After the second 0, all values must be 0.  
 - dummy drive object numbers (255) are only permitted in the first partial list.

---

<b>A01324</b>	<b>Topology: Dummy drive object number incorrectly set-up</b>
<b>Reaction:</b>	NONE
<b>Acknowledge:</b>	NONE
<b>Cause:</b>	In p0978, dummy drive object numbers (255) are only permitted in the first partial list. Alarm value (r2124, decimal): Index of p0978, under which the illegal value is located.
<b>Remedy:</b>	Set p0009 to 1 and change p0978: Rules: - p0978 must include all of the drive object numbers (p0101). - it is not permissible that a drive object number is repeated. - by entering a 0, the drive objects with PZD are separated from those without PZD. - only 2 partial lists are permitted. After the second 0, all values must be 0. - dummy drive object numbers (255) are only permitted in the first partial list.

---

<b>A01330</b>	<b>Topology: Quick commissioning not possible</b>
<b>Reaction:</b>	NONE
<b>Acknowledge:</b>	NONE
<b>Cause:</b>	Unable to carry-out a quick commissioning. The existing actual topology does not fulfill the requirements. Alarm value (r2124, interpret hexadecimal): The cause is in byte 1 supplementary information is included in byte 2 and the high word. Byte 1 = 1: For a component, illegal connections were detected. - Byte 2 = 1: For a Motor Module, more than one motor with DRIVE-CLiQ was detected. - Byte 2 = 2: For a motor with DRIVE-CLiQ, the DRIVE-CLiQ cable is not connected to a Motor Module. - high word = preliminary component number of the component with illegal connection. Byte 1 = 2: The topology contains too many components of a particular type. - Byte 2 = 1: There is more than one Master Control Unit. - Byte 2 = 2: There is more than 1 infeed (8 for a parallel circuit configuration). - Byte 2 = 3: There are more than 10 Motor Modules (8 for a parallel circuit configuration). - Byte 2 = 4: There are more than 9 encoders. - Byte 2 = 5: There are more than 8 Terminal Modules. - Byte 2 = 7: Unknown component type. - Byte 2 = 8: There are more than 6 drive slaves. - Byte 2 = 9: Connection of a drive slave not permitted. - Byte 2 = 10: There is no Drive Master. - Byte 2 = 11: There is more than one motor with DRIVE-CLiQ for a parallel circuit. - high word = not used. Byte 1 = 3: More than 16 components are connected at a DRIVE-CLiQ socket of the Control Unit. - byte 2 = 0, 1, 2, 3 means e.g. detected at the DRIVE-CLiQ socket X100, X101, X102, X103. - high word = not used. Byte 1 = 4: The number of components connected one after the other is greater than 125. - byte 2 = not used. - high word = preliminary component number of the first component and component that resulted in the fault. Byte 1 = 5: The component is not permissible for SERVO. - Byte 2 = 1: SINAMICS G is being used. - Byte 2 = 2: Chassis is being used. - high word = preliminary component number of the first component and component that resulted in the fault. Byte 1 = 6: For a component, illegal EEPROM data was detected. These must be corrected before the system continues to boot. - Byte 2 = 1: The Order No. [MLFB] of the power unit that was replaced includes a space retainer. The space retainer (*) must be replaced by a correct character. - high word = preliminary component number of the component with illegal EEPROM data. Byte 1 = 7:

The actual topology contains an illegal combination of components.  
 - Byte 2 = 1: Active Line Module (ALM) and Basic Line Module (BLM).  
 - Byte 2 = 2: Active Line Module (ALM) and Smart Line Module (SLM).  
 - Byte 2 = 3: SIMOTION control (e.g. SIMOTION D445) and SINUMERIK component (e.g. NX15).  
 - Byte 2 = 4: SINUMERIK control (e.g. SINUMERIK 730.net) and SIMOTION component (e.g. CX32).  
 - high word = not used.

Note:

Connection type and connection number are described in F01375.

See also: p0097 (Select drive object type), r0098 (Actual device topology), p0099 (Device target topology)

**Remedy:**

- adapt the output topology to the permissible requirements.  
 - carry-out commissioning using the commissioning software.  
 - for motors with DRIVE-CLiQ, connect the power and DRIVE-CLiQ cable to the same Motor Module (Single Motor Module: DRIVE-CLiQ at X202, Double Motor Module: DRIVE-CLiQ from motor 1 (X1) to X202, from motor 2 (X2) to X203).

Re byte 1 = 6 and byte 2 = 1:

Correct the order number when commissioning using the commissioning software.

See also: p0097 (Select drive object type), r0098 (Actual device topology), p0099 (Device target topology)

**A01331**

**Topology: At least one component not assigned to a drive object**

**Reaction:**

NONE

**Acknowledge:**

NONE

**Cause:**

At least one component is not assigned to a drive object.  
 - when commissioning, a component was not able to be automatically assigned to a drive object.  
 - the parameters for the data sets are not correctly set.

Alarm value (r2124, decimal):

Component number of the unassigned component.

**Remedy:**

This component is assigned to a drive object.

Check the parameters for the data sets.

Examples:

- power unit (p0121).
- motor (p0131, p0186).
- encoder interface (p0140, p0141, p0187 ... p0189).
- encoder (p0140, p0142, p0187 ... p0189).
- Terminal Module (p0151).
- option board (p0161).

**F01340**

**Topology: Too many components on one line**

**Reaction:**

NONE

**Acknowledge:**

IMMEDIATELY

**Cause:**

For the selected communications clock cycle, too many DRIVE-CLiQ components are connected to one line of the Control Unit.

Fault value (r0949, interpret hexadecimal):

xyy hex: x = fault cause, yy = component number or connection number.

1yy: The communications clock cycle of the DRIVE-CLiQ connection on the CU is not sufficient for all read transfers.

2yy: The communications clock cycle of the DRIVE-CLiQ connection on the CU is not sufficient for all write transfers.

3yy: Cyclic communications is fully utilized.

4yy:

The DRIVE-CLiQ cycle starts before the earliest end of the application. An additional deadtime must be added to the control. Sign-of-life errors can be expected.

5yy: Internal buffer overflow for net data of a DRIVE-CLiQ connection.

6yy: Internal buffer overflow for receive data of a DRIVE-CLiQ connection.

7yy: Internal buffer overflow for send data of a DRIVE-CLiQ connection.

**Remedy:**

Check the DRIVE-CLiQ connection:

Reduce the number of components on the DRIVE-CLiQ line involved and distribute these to other DRIVE-CLiQ connections of the Control Unit. This means that communication is uniformly distributed over several communication lines.

Re fault value = 1yy - 4yy in addition:

- increase the sampling times (p0112, p0115).



<b>F01355</b>	<b>Topology: Actual topology changed</b>
<b>Reaction:</b>	NONE
<b>Acknowledge:</b>	IMMEDIATELY
<b>Cause:</b>	<p>The unit target topology p0099 does not correspond to the unit actual topology r0098. The fault only occurs if the topology was commissioned using the automatic internal device mechanism and not using the commissioning software.</p> <p>Fault value (r0949, decimal): Only for internal Siemens troubleshooting. See also: r0098 (Actual device topology), p0099 (Device target topology)</p>
<b>Remedy:</b>	<p>One of the following counter-measures can be selected if no faults have occurred in the topology detection itself. If commissioning was still not completed:</p> <ul style="list-style-type: none"> <li>- carry-out a self-commissioning routine (starting from p0009 = 1). General: Set p0099 to r0098, set p0009 to 0; for existing Motor Modules, this results in servo drives being automatically generated (refer to p0107).</li> <li>or, to generate servo drives: Set p0097 to 1, set p0009 to 0;</li> <li>or, to generate vector drives: Set p0097 to 2, set p0009 to 0.</li> <li>or, to generate vector drives with parallel circuit: Set p0097 to 12, set p0009 to 0.</li> </ul> <p>In order to set configurations in p0108, before setting p0009 to 0, it is possible to first set p0009 to 2 and p0108 modified (the index corresponds to the drive object, also refer to p0107).</p> <p>If commissioning was already completed:</p> <ul style="list-style-type: none"> <li>- re-establish the original connections and re-connect power to the Control Unit.</li> <li>- restore the factory setting for the complete equipment (all of the drives) and allow automatic self-commissioning again.</li> <li>- change the device parameterization to match the connections (this is only possible using the commissioning software).</li> </ul> <p>Notice: Topology changes, that result in this fault being generated, cannot be accepted by the automatic function in the device, but must be transferred using the commissioning software and parameter download. The automatic function in the device only allows constant topology to be used. Otherwise, when the topology is changed, all of the previous parameter settings are lost and replaced by the factory setting. See also: r0098 (Actual device topology)</p>
<b>F01360</b>	<b>Topology: Actual topology is illegal</b>
<b>Reaction:</b>	NONE
<b>Acknowledge:</b>	IMMEDIATELY
<b>Cause:</b>	<p>The detected actual topology is not permissible.</p> <p>Fault value (r0949, interpret hexadecimal): Byte 1 (cause): 1: Too many components were detected at the Control Unit. The maximum permissible number of components is 199. 2: The component type of a component is not known. The preliminary component number is in the high word. Note: The drive system is no longer booted. In this state, the drive control (closed-loop) cannot be enabled.</p>
<b>Remedy:</b>	<p>Re fault value = 1: Change the configuration. Connect less than 199 components to the Control Unit.</p> <p>Re fault value = 2: Remove the component with unknown component type.</p>
<b>A01361</b>	<b>Topology: Actual topology contains SINUMERIK and SIMOTION components</b>
<b>Reaction:</b>	NONE
<b>Acknowledge:</b>	NONE
<b>Cause:</b>	<p>The detected actual topology contains SINUMERIK and SIMOTION components.</p> <p>Fault value (r0949, interpret hexadecimal): Byte 1: Component number of the component. Byte 2: Component class of the actual topology. Byte 3 (cause): 1: An NX10 or NX15 was connected to a SIMOTION control. 2: A CX32 was connected to a SINUMERIK control. The drive system is no longer booted. In this state, the drive control (closed-loop) cannot be enabled.</p>
<b>Remedy:</b>	<p>Re fault value = 1: Replace all NX10 or NX15 by a CX32. Re fault value = 2: Replace all CX32 by an NX10 or NX15.</p>

<b>F01375</b>	<b>Topology: Actual topology, duplicate connection between two components</b>
<b>Reaction:</b>	NONE
<b>Acknowledge:</b>	IMMEDIATELY
<b>Cause:</b>	<p>When detecting the actual topology, a ring-type connection was detected.                      Fault value (r0949, interpret hexadecimal):                      Low word: Preliminary component number of a component included in the ring                      Byte 3: Component class                      Byte 4: Connection number                      Example:                      Fault value = 33751339 dec = 203012B hex                      Byte 4 = 02 hex = 2 dec, byte 3 = 03 hex = 3 dec, low word = 012B hex = 299 dec                      Component class:                      1: Control unit                      2: Motor Module                      3: Line Module                      4: Sensor Module (SM)                      5: Voltage Sensing Module (VSM)                      6: Terminal Module (TM)                      7: DRIVE-CLiQ Module Cabinet (DMC)                      8: Controller Extension 32 (CX32)                      49: DRIVE-CLiQ components (non-listed components)                      50: Option slot (e.g. Terminal Board 30)                      60: Encoder (e.g. EnDat)                      70: Motor with DRIVE-CLiQ                      Component type:                      Precise designation within a component class (e.g. "SMC20").                      Connection number:                      Consecutive numbers, starting from zero, of the appropriate connection or slot (e.g. DRIVE-CLiQ connection X100 on the Control Unit has the connection number 0).</p>
<b>Remedy:</b>	<p>Output the fault value and remove the specified connection.                      Note:                      Under "Topology --&gt; Topology view" the commissioning software offers improved diagnostics capability (e.g. set-point/actual value comparison).</p>
<b>F01380</b>	<b>Topology: Actual topology, defective EEPROM</b>
<b>Reaction:</b>	NONE
<b>Acknowledge:</b>	POWER ON
<b>Cause:</b>	<p>When detecting the actual topology, a component with a defective EEPROM was detected.                      Fault value (r0949, interpret hexadecimal):                      Low word:                      Preliminary component number of the defective components.</p>
<b>Remedy:</b>	Output the fault value and remove the defected component.
<b>A01381</b>	<b>Topology: Comparison, power unit shifted</b>
<b>Reaction:</b>	NONE
<b>Acknowledge:</b>	NONE
<b>Cause:</b>	<p>The topology comparison has detected a power unit in the actual topology that has been shifted with respect to the target topology.                      Alarm value (r2124, interpret hexadecimal):                      Byte 1: Component number of the component shifted in the target topology.                      The connection in the actual topology where the shifted component was detected, is described in bytes 2, 3 and 4.                      Byte 2: Component class                      Byte 3: Component number                      Byte 4: Connection number                      Note:                      Component class and connection number are described in F01375.                      The drive system is no longer booted. In this state, the drive control (closed-loop) cannot be enabled.</p>

**Remedy:** Adapting the topologies:  
 - undo the change to the actual topology by changing-over the DRIVE-CLiQ cables.  
 - commissioning software: Go online, upload the drive unit, adapt the topology offline and download the modified project.  
 - automatically remove the topology error (p9904).  
**Note:**  
 Under "Topology --> Topology view" the commissioning software offers improved diagnostics capability (e.g. set-point/actual value comparison).

**A01382 Topology: Comparison, Sensor Module shifted**

**Reaction:** NONE

**Acknowledge:** NONE

**Cause:** The topology comparison has detected a Sensor Module in the actual topology that has been shifted with respect to the target topology.  
 Alarm value (r2124, interpret hexadecimal):  
 Byte 1: Component number of the component shifted in the target topology  
 The connection in the actual topology where the shifted component was detected, is described in bytes 2, 3 and 4.  
 Byte 2: Component class  
 Byte 3: Component number  
 Byte 4: Connection number  
**Note:**  
 Component class and connection number are described in F01375.  
 The drive system is no longer booted. In this state, the drive control (closed-loop) cannot be enabled.

**Remedy:** Adapting the topologies:  
 - undo the change to the actual topology by changing-over the DRIVE-CLiQ cables.  
 - commissioning software: Go online, upload the drive unit, adapt the topology offline and download the modified project.  
 - automatically remove the topology error (p9904).  
**Note:**  
 Under "Topology --> Topology view" the commissioning software offers improved diagnostics capability (e.g. set-point/actual value comparison).

**A01383 Topology: Comparison, Terminal Module shifted**

**Reaction:** NONE

**Acknowledge:** NONE

**Cause:** The topology comparison has detected a Terminal Module in the actual topology that has been shifted with respect to the target topology.  
 Alarm value (r2124, interpret hexadecimal):  
 Byte 1: Component number of the component shifted in the target topology  
 The connection in the actual topology where the shifted component was detected, is described in bytes 2, 3 and 4.  
 Byte 2: Component class  
 Byte 3: Component number  
 Byte 4: Connection number  
**Note:**  
 Component class and connection number are described in F01375.  
 The drive system is no longer booted. In this state, the drive control (closed-loop) cannot be enabled.

**Remedy:** Adapting the topologies:  
 - undo the change to the actual topology by changing-over the DRIVE-CLiQ cables.  
 - commissioning software: Go online, upload the drive unit, adapt the topology offline and download the modified project.  
 - automatically remove the topology error (p9904).  
**Note:**  
 Under "Topology --> Topology view" the commissioning software offers improved diagnostics capability (e.g. set-point/actual value comparison).

<b>A01384</b>	<b>Topology: Comparison, DMC shifted</b>
<b>Reaction:</b>	NONE
<b>Acknowledge:</b>	NONE
<b>Cause:</b>	<p>The topology comparison has detected a DRIVE-CLiQ Hub Module Cabinet (DMC) in the actual topology that has been shifted with respect to the target topology.</p> <p>Alarm value (r2124, interpret hexadecimal):</p> <p>Byte 1: Component number of the component shifted in the target topology</p> <p>The connection in the actual topology where the shifted component was detected, is described in bytes 2, 3 and 4.</p> <p>Byte 2: Component class</p> <p>Byte 3: Component number</p> <p>Byte 4: Connection number</p> <p>Note:</p> <p>Component class and connection number are described in F01375.</p> <p>The drive system is no longer booted. In this state, the drive control (closed-loop) cannot be enabled.</p>
<b>Remedy:</b>	<p>Adapting the topologies:</p> <ul style="list-style-type: none"> <li>- undo the change to the actual topology by changing-over the DRIVE-CLiQ cables.</li> <li>- commissioning software: Go online, upload the drive unit, adapt the topology offline and download the modified project.</li> <li>- automatically remove the topology error (p9904).</li> </ul> <p>Note:</p> <p>Under "Topology --&gt; Topology view" the commissioning software offers improved diagnostics capability (e.g. set-point/actual value comparison).</p>
<b>A01385</b>	<b>Topology: Comparison, CX32 shifted</b>
<b>Reaction:</b>	NONE
<b>Acknowledge:</b>	NONE
<b>Cause:</b>	<p>The topology comparison has detected a controller extension 32 (CX32) in the actual topology that has been shifted with respect to the target topology.</p> <p>Alarm value (r2124, interpret hexadecimal):</p> <p>Byte 1: Component number of the component shifted in the target topology</p> <p>The connection in the actual topology where the shifted component was detected, is described in bytes 2, 3 and 4.</p> <p>Byte 2: Component class</p> <p>Byte 3: Component number</p> <p>Byte 4: Connection number</p> <p>Note:</p> <p>Component class and connection number are described in F01375.</p> <p>The drive system is no longer booted. In this state, the drive control (closed-loop) cannot be enabled.</p>
<b>Remedy:</b>	<p>Adapting the topologies:</p> <ul style="list-style-type: none"> <li>- undo the change to the actual topology by changing-over the DRIVE-CLiQ cables.</li> <li>- commissioning software: Go online, upload the drive unit, adapt the topology offline and download the modified project.</li> <li>- automatically remove the topology error (p9904).</li> </ul> <p>Note:</p> <p>Under "Topology --&gt; Topology view" the commissioning software offers improved diagnostics capability (e.g. set-point/actual value comparison).</p>
<b>A01386</b>	<b>Topology: Comparison, DRIVE-CLiQ component shifted</b>
<b>Reaction:</b>	NONE
<b>Acknowledge:</b>	NONE
<b>Cause:</b>	<p>The topology comparison has detected a DRIVE-CLiQ component in the actual topology that has been shifted with respect to the target topology.</p> <p>Alarm value (r2124, interpret hexadecimal):</p> <p>Byte 1: Component number of the component shifted in the target topology</p> <p>The connection in the actual topology where the shifted component was detected, is described in bytes 2, 3 and 4.</p> <p>Byte 2: Component class</p> <p>Byte 3: Component number</p> <p>Byte 4: Connection number</p> <p>Note:</p> <p>Component class and connection number are described in F01375.</p> <p>The drive system is no longer booted. In this state, the drive control (closed-loop) cannot be enabled.</p>

**Remedy:** Adapting the topologies:  
 - undo the change to the actual topology by changing-over the DRIVE-CLiQ cables.  
 - commissioning software: Go online, upload the drive unit, adapt the topology offline and download the modified project.  
 - automatically remove the topology error (p9904).  
**Note:**  
 Under "Topology --> Topology view" the commissioning software offers improved diagnostics capability (e.g. set-point/actual value comparison).

**A01387 Topology: Comparison, option slot component shifted**

**Reaction:** NONE

**Acknowledge:** NONE

**Cause:** The topology comparison has detected a option slot component in the actual topology that has been shifted with respect to the target topology.  
 Alarm value (r2124, interpret hexadecimal):  
 Byte 1: Component number of the component shifted in the target topology  
 The connection in the actual topology where the shifted component was detected, is described in bytes 2, 3 and 4.  
 Byte 2: Component class  
 Byte 3: Component number  
 Byte 4: Connection number  
**Note:**  
 Component class and connection number are described in F01375.  
 The drive system is no longer booted. In this state, the drive control (closed-loop) cannot be enabled.

**Remedy:** Adapting the topologies:  
 - undo the change to the actual topology by changing-over the DRIVE-CLiQ cables.  
 - commissioning software: Go online, upload the drive unit, adapt the topology offline and download the modified project.  
 - automatically remove the topology error (p9904).  
**Note:**  
 Under "Topology --> Topology view" the commissioning software offers improved diagnostics capability (e.g. set-point/actual value comparison).

**A01388 Topology: Comparison, EnDat encoder shifted**

**Reaction:** NONE

**Acknowledge:** NONE

**Cause:** The topology comparison has detected an EnDat encoder in the actual topology that has been shifted with respect to the target topology.  
 Alarm value (r2124, interpret hexadecimal):  
 Byte 1: Component number of the component shifted in the target topology  
 The connection in the actual topology where the shifted component was detected, is described in bytes 2, 3 and 4.  
 Byte 2: Component class  
 Byte 3: Component number  
 Byte 4: Connection number  
**Note:**  
 Component class and connection number are described in F01375.  
 The drive system is no longer booted. In this state, the drive control (closed-loop) cannot be enabled.

**Remedy:** Adapting the topologies:  
 - undo the change to the actual topology by changing-over the DRIVE-CLiQ cables.  
 - commissioning software: Go online, upload the drive unit, adapt the topology offline and download the modified project.  
 - automatically remove the topology error (p9904).  
**Note:**  
 Under "Topology --> Topology view" the commissioning software offers improved diagnostics capability (e.g. set-point/actual value comparison).

<b>A01389</b>	<b>Topology: Comparison, motor with DRIVE-CLiQ shifted</b>
<b>Reaction:</b>	NONE
<b>Acknowledge:</b>	NONE
<b>Cause:</b>	<p>The topology comparison has detected a motor with DRIVE-CLiQ in the actual topology that has been shifted with respect to the target topology.</p> <p>Alarm value (r2124, interpret hexadecimal):</p> <p>Byte 1: Component number of the component shifted in the target topology</p> <p>The connection in the actual topology where the shifted component was detected, is described in bytes 2, 3 and 4.</p> <p>Byte 2: Component class</p> <p>Byte 3: Component number</p> <p>Byte 4: Connection number</p> <p>Note:</p> <p>Component class and connection number are described in F01375.</p> <p>The drive system is no longer booted. In this state, the drive control (closed-loop) cannot be enabled.</p>
<b>Remedy:</b>	<p>Adapting the topologies:</p> <ul style="list-style-type: none"> <li>- undo the change to the actual topology by changing-over the DRIVE-CLiQ cables.</li> <li>- commissioning software: Go online, upload the drive unit, adapt the topology offline and download the modified project.</li> <li>- automatically remove the topology error (p9904).</li> </ul> <p>Note:</p> <p>Under "Topology --&gt; Topology view" the commissioning software offers improved diagnostics capability (e.g. set-point/actual value comparison).</p>

<b>A01416</b>	<b>Topology: Comparison, additional component in actual topology</b>
<b>Reaction:</b>	NONE
<b>Acknowledge:</b>	NONE
<b>Cause:</b>	<p>The topology comparison has found a component in the actual topology which is not specified in the target topology. The alarm value includes the component number and connection number of the component with which the additional component is connected.</p> <p>Alarm value (r2124, interpret hexadecimal):</p> <p>Byte 1: Component number</p> <p>Byte 2: Component class of the additional component</p> <p>Byte 3: Connection number</p> <p>Note:</p> <p>Component class and connection number are described in F01375.</p>
<b>Remedy:</b>	<p>Adapting the topologies:</p> <ul style="list-style-type: none"> <li>- remove the additional component in the actual topology.</li> <li>- download the target topology that matches the actual topology (commissioning software).</li> </ul> <p>Note:</p> <p>Under "Topology --&gt; Topology view" the commissioning software offers improved diagnostics capability (e.g. set-point/actual value comparison).</p>

---

<b>A01420</b>	<b>Topology: Comparison, a component is different</b>
<b>Reaction:</b>	NONE
<b>Acknowledge:</b>	NONE
<b>Cause:</b>	<p>The topology comparison has detected differences in the actual and target topologies in relation to one component. There are differences in the electronic rating plate.</p> <p>Alarm value (r2124, interpret hexadecimal):</p> <p>Byte 1: Component number of the component</p> <p>Byte 2: Component class of the target topology</p> <p>Byte 3: Component class of the actual topology</p> <p>Byte 4 (cause):</p> <ol style="list-style-type: none"> <li>1: Different component type</li> <li>2: Different order number</li> <li>3: Different manufacturer</li> <li>4: Connection changed-over for a multi-component slave (e.g. double Motor Module) or defective EEPROM data in the electronic rating plate</li> <li>5: A CX32 was replaced by an NX10 or NX15.</li> <li>6: An NX10 or NX15 was replaced by a CX32.</li> </ol> <p>Note:</p> <p>Component class and component type are described in F01375.</p> <p>The drive system is no longer booted. In this state, the drive control (closed-loop) cannot be enabled.</p>
<b>Remedy:</b>	<p>Adapting the topologies:</p> <ul style="list-style-type: none"> <li>- check the component soft-wired connections against the hardware configuration of the drive unit in the commissioning software and correct differences.</li> <li>- parameterize the topology comparison of all components (p9906).</li> <li>- parameterize the topology comparison of one components (p9907, p9908).</li> </ul> <p>Note:</p> <p>Under "Topology --&gt; Topology view" the commissioning software offers improved diagnostics capability (e.g. set-point/actual value comparison).</p>

---

<b>A01421</b>	<b>Topology: Comparison, different components</b>
<b>Reaction:</b>	NONE
<b>Acknowledge:</b>	NONE
<b>Cause:</b>	<p>The topology comparison has detected differences in the actual and target topologies in relation to one component. The component class, the component type or the number of connections differ.</p> <p>Alarm value (r2124, interpret hexadecimal):</p> <p>Byte 1: Component number of the component</p> <p>Byte 2: Component class of the target topology</p> <p>Byte 3: Component class of the actual topology</p> <p>Byte 4 (cause):</p> <ol style="list-style-type: none"> <li>1: Different component class</li> <li>2: Different component type</li> <li>3: Different order number</li> <li>4: Different number of connections</li> </ol> <p>Note:</p> <p>Component class, component type and connection number are described in F01375.</p> <p>The drive system is no longer booted. In this state, the drive control (closed-loop) cannot be enabled.</p>
<b>Remedy:</b>	<p>Check the component soft-wired connections against the hardware configuration of the drive unit in the commissioning software and correct differences.</p> <p>Note:</p> <p>Under "Topology --&gt; Topology view" the commissioning software offers improved diagnostics capability (e.g. set-point/actual value comparison).</p>

<b>A01425</b>	<p><b>Topology: Comparison, serial number of a component is different</b></p> <p><b>Reaction:</b> NONE</p> <p><b>Acknowledge:</b> NONE</p> <p><b>Cause:</b> The topology comparison has detected differences in the actual and target topologies in relation to one component. The serial number is different. Alarm value (r2124, interpret hexadecimal): Byte 1: Component number of the component Byte 2: Component class Byte 3: Number of differences Note: The component class is described in F01375. The drive system is no longer booted. In this state, the drive control (closed-loop) cannot be enabled.</p> <p><b>Remedy:</b> Adapting the topologies: - change over the actual topology to match the target topology. - download the target topology that matches the actual topology (commissioning software). Re byte 3: Byte 3 = 1 --&gt; can be acknowledged using p9904 or p9905. Byte 3 &gt; 1 --&gt; can be acknowledged using p9905 and can be de-activated using p9906 or p9907/p9908. Note: Under "Topology --&gt; Topology view" the commissioning software offers improved diagnostics capability (e.g. set-point/actual value comparison). See also: p9904 (Topology comparison, acknowledge differences), p9905 (Device specialization), p9906 (Topology comparison, comparison stage of all components), p9907 (Topology comparison, comparison stage of the component number), p9908 (Topology comparison, comparison stage of a component)</p>
<b>A01428</b>	<p><b>Topo: Comparison, connection of a component is different</b></p> <p><b>Reaction:</b> NONE</p> <p><b>Acknowledge:</b> NONE</p> <p><b>Cause:</b> The topology comparison has detected differences in the actual and target topologies in relation to one component. A component was connected to another connection. The different connections of a component are described in the alarm value: Alarm value (r2124, interpret hexadecimal): Byte 1: Component number Byte 2: Component class Byte 3: Connection number of the actual topology Byte 4: Connection number of the target topology Note: Component class and connection number are described in F01375. The drive system is no longer booted. In this state, the drive control (closed-loop) cannot be enabled.</p> <p><b>Remedy:</b> Adapting the topologies: - change over the actual topology to match the target topology. - download the target topology that matches the actual topology (commissioning software). - automatically remove the topology error (p9904). Note: Under "Topology --&gt; Topology view" the commissioning software offers improved diagnostics capability (e.g. set-point/actual value comparison). See also: p9904 (Topology comparison, acknowledge differences)</p>



<b>A01429</b>	<b>Topology: Comparison, connection is different for more than component</b>
<b>Reaction:</b>	NONE
<b>Acknowledge:</b>	NONE
<b>Cause:</b>	<p>A topology comparison has found differences between the actual and target topology for several components. A component was connected to another connection.</p> <p>The different connections of a component are described in the alarm value:                      Alarm value (r2124, interpret hexadecimal):                      Byte 1: Component number                      Byte 2: Component class                      Byte 3: Connection number of the actual topology                      Byte 4: Connection number of the target topology</p> <p>Note:                      Component class and connection number are described in F01375.                      The drive system is no longer booted. In this state, the drive control (closed-loop) cannot be enabled.</p>
<b>Remedy:</b>	<p>Adapting the topologies:                      - change over the actual topology to match the target topology.                      - download the target topology that matches the actual topology (commissioning software).</p> <p>Note:                      In the software, a double Motor Module behaves just like two separate DRIVE-CLiQ nodes. If a double Motor Module is re-inserted, this can result in several differences in the actual topology.</p> <p>Note:                      Under "Topology --&gt; Topology view" the commissioning software offers improved diagnostics capability (e.g. set-point/actual value comparison).</p>
<b>F01451</b>	<b>Topology: Target topology is invalid</b>
<b>Reaction:</b>	NONE
<b>Acknowledge:</b>	IMMEDIATELY
<b>Cause:</b>	<p>An error has occurred when writing into the target topology.                      The write operation was interrupted due to an invalid target topology.                      Fault value (r0949, interpret hexadecimal):                      Only for internal Siemens troubleshooting.</p>
<b>Remedy:</b>	Reload the target topology using the commissioning software.
<b>F01470</b>	<b>Topology: Target topology ring-type connection</b>
<b>Reaction:</b>	NONE
<b>Acknowledge:</b>	IMMEDIATELY
<b>Cause:</b>	<p>A ring-type connection was detected when writing into the target topology.                      Fault value (r0949, interpret hexadecimal):                      Byte 1: Component number of a component included in the ring                      Byte 2: Component class                      Byte 3: Connection number</p> <p>Note:                      Component class and connection number are described in F01375.</p>
<b>Remedy:</b>	<p>Read-out the fault value and remove one of the specified connections.                      Then, download the target topology again using the commissioning software.</p> <p>Note:                      Under "Topology --&gt; Topology view" the commissioning software offers improved diagnostics capability (e.g. set-point/actual value comparison).</p>

<b>F01475</b>	<b>Topology: Target topology, duplicate connection between two components</b>
<b>Reaction:</b>	NONE
<b>Acknowledge:</b>	IMMEDIATELY
<b>Cause:</b>	When writing the target topology, a duplicate connection between two components was detected. Fault value (r0949, interpret hexadecimal): Byte 1: Component number of one of the components connected twice Byte 2: Component class Byte 3: Connection number 1 of the duplicate connection Byte 4: Connection number 2 of the duplicate connection Note: Component class and connection number are described in F01375.
<b>Remedy:</b>	Read-out the fault value and remove one of the two specified connections. Then, download the target topology again using the commissioning software. Note: Under "Topology --> Topology view" the commissioning software offers improved diagnostics capability (e.g. set-point/actual value comparison).
<b>A01481</b>	<b>Topology: Comparison, power unit missing in the actual topology</b>
<b>Reaction:</b>	NONE
<b>Acknowledge:</b>	NONE
<b>Cause:</b>	The topology comparison has detected a power unit in the target topology that is not available in the actual topology. Alarm value (r2124, decimal): Component number of the additional target components. Note: The drive system is no longer booted. In this state, the drive control (closed-loop) cannot be enabled.
<b>Remedy:</b>	- delete the drive belonging to the power unit in the commissioning software project and download the new configuration into the drive unit. - check that the actual topology matches the target topology and if required, change over. - check DRIVE-CLiQ cables for interruption and contact problems. Note: Under "Topology --> Topology view" the commissioning software offers improved diagnostics capability (e.g. set-point/actual value comparison).
<b>A01482</b>	<b>Topology: Comparison, Sensor Module missing in the actual topology</b>
<b>Reaction:</b>	NONE
<b>Acknowledge:</b>	NONE
<b>Cause:</b>	The topology comparison has detected a Sensor Module in the target topology that is not available in the actual topology. Alarm value (r2124, decimal): Component number of the additional target components. Note: The drive system is no longer booted. In this state, the drive control (closed-loop) cannot be enabled.
<b>Remedy:</b>	- re-configure the drive belonging to the Sensor Module in the commissioning software project (encoder configuration) and download the new configuration into the drive unit. - delete the drive belonging to the Sensor Module in the commissioning software project and download the new configuration into the drive unit. - check that the actual topology matches the target topology and if required, change over. - check DRIVE-CLiQ cables for interruption and contact problems. Note: Under "Topology --> Topology view" the commissioning software offers improved diagnostics capability (e.g. set-point/actual value comparison).

---

<b>A01483</b>	<b>Topology: Comparison, Terminal Module missing in the actual topology</b>
<b>Reaction:</b>	NONE
<b>Acknowledge:</b>	NONE
<b>Cause:</b>	The topology comparison has detected a Terminal Module in the target topology that is not available in the actual topology. Alarm value (r2124, decimal): Component number of the additional target components. Note: The drive system is no longer booted. In this state, the drive control (closed-loop) cannot be enabled.
<b>Remedy:</b>	- delete the Terminal Module in the commissioning software project and download the new configuration into the drive unit. - check that the actual topology matches the target topology and if required, change over. - check DRIVE-CLiQ cables for interruption and contact problems. Note: Under "Topology --> Topology view" the commissioning software offers improved diagnostics capability (e.g. set-point/actual value comparison).

---

<b>A01484</b>	<b>Topology: Comparison, DMC missing in the actual topology</b>
<b>Reaction:</b>	NONE
<b>Acknowledge:</b>	NONE
<b>Cause:</b>	The topology comparison has detected a DRIVE-CLiQ Hub Module Cabinet (DMC) in the target topology that is not available in the actual topology. Alarm value (r2124, decimal): Component number of the additional target components. Note: The drive system is no longer booted. In this state, the drive control (closed-loop) cannot be enabled.
<b>Remedy:</b>	- delete the DRIVE-CLiQ Hub Module Cabinet (DMC) in the commissioning software project and download the new configuration into the drive unit. - check that the actual topology matches the target topology and if required, change over. - check DRIVE-CLiQ cables for interruption and contact problems. Note: Under "Topology --> Topology view" the commissioning software offers improved diagnostics capability (e.g. set-value/actual value comparison).

---

<b>A01485</b>	<b>Topology: Comparison, CX32 missing in the actual topology</b>
<b>Reaction:</b>	NONE
<b>Acknowledge:</b>	NONE
<b>Cause:</b>	The topology comparison has detected a controller extension 32 (CX32) in the target topology that is not available in the actual topology. Alarm value (r2124, decimal): Component number of the additional target components. Note: The drive system is no longer booted. In this state, the drive control (closed-loop) cannot be enabled.
<b>Remedy:</b>	- delete the CX32 in the commissioning software project and download the new configuration into the drive unit. - check that the actual topology matches the target topology and if required, change over. - check DRIVE-CLiQ cables for interruption and contact problems. Note: Under "Topology --> Topology view" the commissioning software offers improved diagnostics capability (e.g. set-point/actual value comparison).

<b>A01486</b>	<p><b>Topology: Comparison, DRIVE-CLiQ components missing in the actual topology</b></p> <p><b>Reaction:</b> NONE</p> <p><b>Acknowledge:</b> NONE</p> <p><b>Cause:</b> The topology comparison has detected a DRIVE-CLiQ component in the target topology that is not available in the actual topology. Alarm value (r2124, decimal): Component number of the additional target components. Note: The drive system is no longer booted. In this state, the drive control (closed-loop) cannot be enabled.</p> <p><b>Remedy:</b></p> <ul style="list-style-type: none"> <li>- delete the drive belonging to this component in the commissioning software project and download the new configuration into the drive unit.</li> <li>- re-configure the drive belonging to this component in the commissioning software project and download the new configuration into the drive unit.</li> <li>- check that the actual topology matches the target topology and if required, change over.</li> <li>- check DRIVE-CLiQ cables for interruption and contact problems.</li> </ul> <p>Note: Under "Topology --&gt; Topology view" the commissioning software offers improved diagnostics capability (e.g. set-point/actual value comparison).</p>
<b>A01487</b>	<p><b>Topology: Comparison, option slot components missing in the actual topology</b></p> <p><b>Reaction:</b> NONE</p> <p><b>Acknowledge:</b> NONE</p> <p><b>Cause:</b> The topology comparison has detected an option slot module in the target topology that is not available in the actual topology. Alarm value (r2124, decimal): Component number of the additional target components. Note: The drive system is no longer booted. In this state, the drive control (closed-loop) cannot be enabled.</p> <p><b>Remedy:</b></p> <ul style="list-style-type: none"> <li>- delete the option board in the commissioning software project and download the new configuration into the drive unit.</li> <li>- re-configure the drive unit in the commissioning software project and download the new configuration into the drive unit.</li> <li>- check that the actual topology matches the target topology and if required, change over.</li> </ul> <p>Note: Under "Topology --&gt; Topology view" the commissioning software offers improved diagnostics capability (e.g. set-point/actual value comparison).</p>
<b>A01488</b>	<p><b>Topology: Comparison, EnDat encoder missing in the actual topology</b></p> <p><b>Reaction:</b> NONE</p> <p><b>Acknowledge:</b> NONE</p> <p><b>Cause:</b> The topology comparison has detected an EnDat encoder in the target topology that is not available in the actual topology. Alarm value (r2124, decimal): Component number of the additional target components. Note: The drive system is no longer booted. In this state, the drive control (closed-loop) cannot be enabled.</p> <p><b>Remedy:</b></p> <ul style="list-style-type: none"> <li>- re-configure the drive belonging to the encoder in the commissioning software project (encoder configuration) and download the new configuration into the drive unit.</li> <li>- delete the drive belonging to the encoder in the commissioning software project and download the new configuration into the drive unit.</li> <li>- check that the actual topology matches the target topology and if required, change over.</li> </ul> <p>Note: Under "Topology --&gt; Topology view" the commissioning software offers improved diagnostics capability (e.g. set-point/actual value comparison).</p>

<b>A01489</b>	<b>Topology: Comparison, motor with DRIVE-CLiQ missing in the actual topology</b>
<b>Reaction:</b>	NONE
<b>Acknowledge:</b>	NONE
<b>Cause:</b>	The topology comparison has detected a motor with DRIVE-CLiQ in the target topology that is not available in the actual topology. Alarm value (r2124, decimal): Component number of the additional target components. Note: The drive system is no longer booted. In this state, the drive control (closed-loop) cannot be enabled.
<b>Remedy:</b>	- re-configure the drive belonging to this motor in the commissioning software project and download the new configuration into the drive unit. - delete the drive belonging to this motor in the commissioning software project and download the new configuration into the drive unit. - check that the actual topology matches the target topology and if required, change over. - check DRIVE-CLiQ cables for interruption and contact problems. Note: Under "Topology --> Topology view" the commissioning software offers improved diagnostics capability (e.g. set-point/actual value comparison).
<b>F01505 (A)</b>	<b>BICO: Interconnection cannot be established</b>
<b>Reaction:</b>	NONE
<b>Acknowledge:</b>	IMMEDIATELY
<b>Cause:</b>	A PROFIBUS telegram has been set (p0922). An interconnection contained in the telegram, was not able to be established. Fault value (r0949, decimal): Parameter receiver that should be changed.
<b>Remedy:</b>	Establish another interconnection.
Reaction upon A:	NONE
Acknowledge upon A:	NONE
<b>F01506 (A)</b>	<b>BICO: No standard telegram</b>
<b>Reaction:</b>	NONE
<b>Acknowledge:</b>	IMMEDIATELY
<b>Cause:</b>	The standard telegram in p0922 is not maintained and therefore p0922 is set to 999. Fault value (r0949, decimal): BICO parameter for which the write attempt was unsuccessful.
<b>Remedy:</b>	Again set the required standard telegram (p0922).
Reaction upon A:	NONE
Acknowledge upon A:	NONE
<b>F01507 (N, A)</b>	<b>BICO: Interconnections to inactive objects present</b>
<b>Reaction:</b>	A_INFEED: OFF2 (NONE, OFF1) SERVO: OFF2 (DCBRAKE, ENCODER, NONE, OFF1, OFF3, STOP1, STOP2) VECTOR: OFF2 (DCBRAKE, ENCODER, NONE, OFF1, OFF3, STOP1, STOP2)
<b>Acknowledge:</b>	IMMEDIATELY
<b>Cause:</b>	There are BICO interconnections as signal drain from a drive object that is either inactive/not operational. The BI/CI parameters involved are listed in r9498. The associated BO/CO parameters are listed in r9499. The list of the BICO interconnections to other drive objects is displayed in r9491 and r9492 of the de-activated drive object. Note: r9498 and r9499 are only written into, if p9495 is not set to 0. Alarm value (r2124, decimal): Number of BICO interconnections found to inactive drive objects.
<b>Remedy:</b>	- set all open BICO interconnections centrally to the factory setting with p9495 = 2. - make the non-operational drive object active/operational again (re-insert or activate components).

Reaction upon N: NONE  
 Acknowledge upon N: NONE  
 Reaction upon A: NONE  
 Acknowledge upon A: NONE

---

**F01510 BICO: Signal source is not float type**  
**Reaction:** NONE  
**Acknowledge:** IMMEDIATELY  
**Cause:** The selected connector output does not have the correct data type. This interconnection is not established.  
 Fault value (r0949, decimal):  
 Parameter number to which an interconnection should be made (connector output).  
**Remedy:** Interconnect this connector input with a connector output having a float data type.

---

**F01511 (A) BICO: Interconnection between various normalizations**  
**Reaction:** NONE  
**Acknowledge:** IMMEDIATELY  
**Cause:** The requested interconnection was set up. However, a conversion is made between the BICO output and BICO input using the reference values.  
 - the BICO output has different normalized units than the BICO input.  
 - message only for interconnections within a drive object.  
 Message during commissioning and download inactive.  
 Example:  
 The BICO output has, as normalized unit, voltage and the BICO input has current.  
 This means that the factor p2002 (contains the reference value for current) / p2001 (contains the reference value for voltage) is calculated between the BICO output and BICO input.  
 Fault value (r0949, decimal):  
 Parameter number of the BICO input (signal receiver).  
**Remedy:** No correction needed.  
 Reaction upon A: NONE  
 Acknowledge upon A: NONE

---

**F01512 BICO: No normalization available**  
**Reaction:** A\_INFEED: OFF2 (OFF1)  
 SERVO: OFF2  
 VECTOR: OFF2  
**Acknowledge:** POWER ON  
**Cause:** An attempt was made to determine a conversion factor for a normalization that does not exist.  
 Fault value (r0949, decimal):  
 Unit (e.g. corresponding to SPEED) for which an attempt was made to determine a factor.  
**Remedy:** Apply normalization or check the transfer value.

---

**F01513 (A) BICO: Spanning DO between different normalizations**  
**Reaction:** NONE  
**Acknowledge:** IMMEDIATELY  
**Cause:** The requested interconnection was set up. However, a conversion is made between the BICO output and BICO input using the reference values.  
 An interconnection is made between different drive objects and the BICO output has different normalized units than the BICO input or the normalized units are the same but the reference values are different.  
 Example:  
 The BICO output has, as standard unit, voltage and the BICO input has current; both lie in different drive objects.  
 This means that the factor p2002 (contains the reference value for current) / p2001 (contains the reference value for voltage) is calculated between the BICO output and BICO input.  
 Fault value (r0949, decimal):  
 Parameter number of the BICO input (signal receiver).  
**Remedy:** No correction needed.

Reaction upon A: NONE  
 Acknowledge upon A: NONE

---

**A01514 (F) BICO: Error when writing during a reconnect**

**Reaction:** NONE  
**Acknowledge:** NONE  
**Cause:** During a reconnect operation (e.g. while booting or downloading - but cannot occur in normal operation) a parameter was not able to be written into.  
 Example: When writing to a double word BICO input in the second index, the memory areas overlap (e.g. p8861). The parameter is then reset to the factory setting.  
 Alarm value (r2124, decimal): Parameter number of the BICO input (signal receiver).  
**Remedy:** None necessary.  
 Reaction upon F: NONE  
 Acknowledge upon F: IMMEDIATELY

---

**F01515 (A) BICO: Writing to parameter not permitted as the master control is active**

**Reaction:** NONE  
**Acknowledge:** IMMEDIATELY  
**Cause:** While changing the number of CDS or when copying from CDS, the master control was active.  
**Remedy:** None necessary.  
 Reaction upon A: NONE  
 Acknowledge upon A: NONE

---

**A01590 (F) Drive: Motor maintenance interval expired**

**Reaction:** NONE  
**Acknowledge:** NONE  
**Cause:** The selected service/maintenance interval for this motor was reached.  
 Alarm value (r2124, decimal): Motor data set number.  
 See also: p0650 (Actual motor operating hours), p0651 (Motor operating hours maintenance interval)  
**Remedy:** Carry-out service/maintenance and reset the service/maintenance interval (p0651).  
 Reaction upon F: NONE  
 Acknowledge upon F: IMMEDIATELY

---

**F01600 SI CU: STOP A initiated**

**Reaction:** OFF2  
**Acknowledge:** IMMEDIATELY (POWER ON)  
**Cause:** The drive-based "Safety Integrated" function in the Control Unit (CU) has detected a fault and initiated a STOP A (pulse cancellation via the safety shutdown path of the Control Unit).  
 - forced checking procedure of the safety shutdown path of the Control Unit unsuccessful.  
 - subsequent response to fault F01611 (defect in a monitoring channel).  
 Fault value (r0949, decimal):  
 0: Stop request from the Motor Module.  
 1005: Pulses cancelled although SH not selected and there is not internal STOP A present.  
 1010: Pulses enabled although SH is selected or an internal STOP A is present.  
 1015: Feedback of the safe pulse cancellation for Motor Modules connected in parallel are different.  
 9999: Subsequent response to fault F01611.  
**Remedy:**  
 - select safe standstill and then de-select again.  
 - replace the Motor Module involved.  
 Re fault value = 9999:  
 - carry-out diagnostics for fault F01611.  
 Note: CU: Control Unit  
 MM: Motor Module  
 SH: Safe standstill, SI: Safety Integrated

<b>F01611</b>	<b>SI CU: Defect in a monitoring channel".</b>
<b>Reaction:</b>	NONE (OFF1, OFF2, OFF3)
<b>Acknowledge:</b>	IMMEDIATELY (POWER ON)
<b>Cause:</b>	<p>The drive-based "Safety Integrated" function in the Control Unit (CU) has detected a fault in the crosswise data comparison between the CU and Motor Module (MM) and initiated a STOP F.</p> <p>As a result of this fault, after the parameterized transition has expired (p9658), fault F01600 (SI CU: STOP A initiated) is output.</p> <p>Fault value (r0949, decimal):</p> <p>0: Stop request from the Motor Module.</p> <p>1 to 999:</p> <p>Number of the crosswise compared data that resulted in this fault.</p> <p>1: SI monitoring clock cycle (r9780, r9880).</p> <p>2: SI enable safety functions (p9601, p9801).</p> <p>3: SI SGE changeover tolerance time (p9650, p9850).</p> <p>4: SI transition period STOP F to STOP A (p9658, p9858).</p> <p>5: SI enable Safe Brake Control (p9602, p9802).</p> <p>6: SI motion enable, safety-relevant functions (p9501, internal value). This number is also displayed in r9795.</p> <p>7: SI pulse cancellation delay time for Safe Stop 1 (p9652, p9852).</p> <p>8: SI PROFIsafe address (p9610, p9810).</p> <p>1000: Watchdog timer has expired. Within the time of approx. <math>5 * p9650</math> too many switching operations have occurred at terminal EP of the Motor Module.</p> <p>1001: Initialization error, change timer / check timer.</p> <p>2000: Status of the SH terminals on the Control Unit and Motor Module are different.</p> <p>2001: Feedback signal for safe pulse cancellation on the Control Unit and Motor Module are different.</p> <p>2002: Status of the delay timer SS1 on the Control Unit and Motor Module are different.</p> <p>2004: Status of the SH selection for modules connected in parallel are different.</p> <p>2005: Feedback signal of the safe pulse cancellation on the Control Unit and Motor Modules connected in parallel are different.</p>
<b>Remedy:</b>	<p>Re fault value = 1 to 999:</p> <ul style="list-style-type: none"> <li>- check the crosswise compared data that resulted in a STOP F.</li> <li>- carry-out a POWER ON (power off/on) for all components.</li> <li>- upgrade the Motor Module software.</li> <li>- upgrade the Control Unit software.</li> </ul> <p>Re fault value = 1000:</p> <ul style="list-style-type: none"> <li>- check the EP terminal at the Motor Module (contact problems).</li> </ul> <p>Re fault value = 1001, 1002:</p> <ul style="list-style-type: none"> <li>- carry-out a POWER ON (power off/on) for all components.</li> <li>- upgrade the Motor Module software.</li> <li>- upgrade the Control Unit software.</li> </ul> <p>Re fault value = 2000, 2001, 2002, 2004, 2005:</p> <ul style="list-style-type: none"> <li>- check the tolerance time SGE changeover and if required, increase the value (p9650/p9850, p9652/p9852).</li> <li>- check the wiring of the safety-relevant inputs (SGE) (contact problems).</li> <li>- replace the Motor Module involved.</li> </ul> <p>Note:</p> <p>CU: Control Unit</p> <p>EP: Enable Pulses (pulse enable)</p> <p>MM: Motor Module</p> <p>SGE: Safety-relevant input</p> <p>SH: Safe standstill</p> <p>SI: Safety Integrated</p> <p>SS1: Safe Stop 1 (corresponds to Stop Category 1 acc. to EN60204)</p>



---

**N01620 (F, A) SI CU: Safe standstill active**

**Reaction:** NONE  
**Acknowledge:** NONE  
**Cause:** The "safe standstill" function has been selected on the Control Unit (CU) and is active.  
**Note:**  
 This message does not result in a safety stop response.  
**Remedy:** None necessary.  
**Note:**  
 CU: Control Unit  
 SI: Safety Integrated  
 Reaction upon F: OFF2  
 Acknowledge upon F: IMMEDIATELY (POWER ON)  
 Reaction upon A: NONE  
 Acknowledge upon A: NONE

---

**N01621 (F, A) SI CU: Safe Stop 1 active**

**Reaction:** NONE  
**Acknowledge:** NONE  
**Cause:** The "Safe Stop 1" (SS1) function has been selected on the Control Unit (CU) and is active.  
**Note:**  
 This message does not result in a safety stop response.  
**Remedy:** None necessary.  
**Note:**  
 CU: Control Unit  
 SI: Safety Integrated  
 SS1: Safe Stop 1 (corresponds to Stop Category 1 acc. to EN60204)  
 Reaction upon F: OFF3  
 Acknowledge upon F: IMMEDIATELY (POWER ON)  
 Reaction upon A: NONE  
 Acknowledge upon A: NONE

---

**F01625 SI CU: Sign-of-life error in safety data**

**Reaction:** OFF2  
**Acknowledge:** IMMEDIATELY (POWER ON)  
**Cause:** The drive-based "Safety Integrated" function in the Control Unit (CU) has detected an error in the sign-of-life of the safety data between the CU and Motor Module (MM) and initiated a STOP A.  
 - there is either a DRIVE-CLiQ communications error or communications have failed.  
 - a time slice overflow of the safety software has occurred.  
 Fault value (r0949, decimal):  
 Only for internal Siemens troubleshooting.  
**Remedy:**  
 - select safe standstill and then de-select again.  
 - carry-out a POWER ON (power off/on) for all components.  
 - check whether there is a DRIVE-CLiQ communications error between the Control Unit and the Motor Module involved and if required, carry-out a diagnostics routine for the faults identified.  
 - de-select all drive functions that are not absolutely necessary.  
 - reduce the number of drives.  
 - check the electrical cabinet design and cable routing for EMC compliance  
**Note:**  
 CU: Control Unit  
 MM: Motor Module  
 SI: Safety Integrated

<b>F01630</b>	<b>SI CU: Braking signal error</b>
<b>Reaction:</b>	OFF2
<b>Acknowledge:</b>	IMMEDIATELY (POWER ON)
<b>Cause:</b>	<p>The drive-based "Safety Integrated" function in the Control Unit (CU) has detected a braking signal error and initiated a STOP A.</p> <ul style="list-style-type: none"> <li>- no motor holding brake connected.</li> <li>- the motor holding brake control on the Motor Module is faulty.</li> <li>- a DRIVE-CLiQ communications error has occurred between the Control Unit and the Motor Module involved.</li> </ul> <p>Fault value (r0949, decimal):</p> <p>10: No brake connected or fault in the Motor Module brake control circuit ("open brake" operation).            11: Defect in the brake control circuit of the Motor Module ("brake open" operation).            20: Short-circuit in the brake winding or fault in the brake control circuit of the Motor Module ("brake open" state).            30: No brake connected, short-circuit in the brake winding or fault in the Motor Module brake control circuit ("close brake" operation).            31: Defect in the brake control circuit of the Motor Module ("close brake" operation).            40: Defect in the brake control circuit of the Motor Module ("brake closed" state).            50: Defect in the brake control circuit of the Motor Module or communications fault between the Control Unit and the Motor Module (braking signal diagnostics).</p>
<b>Remedy:</b>	<ul style="list-style-type: none"> <li>- select safe standstill and then de-select again.</li> <li>- check the motor holding brake connection.</li> <li>- check the function of the motor holding brake.</li> <li>- check whether there is a DRIVE-CLiQ communications error between the Control Unit and the Motor Module involved and if required, carry-out a diagnostics routine for the faults identified.</li> <li>- check the electrical cabinet design and cable routing for EMC compliance</li> <li>- replace the Motor Module involved.</li> </ul> <p>Operation with Safe Brake Module:</p> <ul style="list-style-type: none"> <li>- check the Safe Brake Modules connection.</li> <li>- replace the Safe Brake Module.</li> </ul> <p>Note:            CU: Control Unit            MM: Motor Module            SI: Safety Integrated</p>

<b>F01649</b>	<b>SI CU: Internal software error</b>
<b>Reaction:</b>	OFF2
<b>Acknowledge:</b>	IMMEDIATELY (POWER ON)
<b>Cause:</b>	<p>An internal error in the Safety Integrated software on the Control Unit has occurred.</p> <p>Note:            This fault results in a STOP A that cannot be acknowledged.            Fault value (r0949, interpret hexadecimal):            Only for internal Siemens troubleshooting.</p>
<b>Remedy:</b>	<ul style="list-style-type: none"> <li>- carry-out a POWER ON (power off/on) for all components.</li> <li>- re-commission the "Safety Integrated" function and carry-out a POWER ON.</li> <li>- upgrade the Control Unit software.</li> <li>- contact the Hotline.</li> <li>- replace the Control Unit.</li> </ul> <p>Note:            CU: Control Unit            MM: Motor Module            SI: Safety Integrated</p>

<b>F01650</b>	<b>SI CU: Acceptance test required</b>
<b>Reaction:</b>	OFF2
<b>Acknowledge:</b>	IMMEDIATELY (POWER ON)
<b>Cause:</b>	<p>The drive-based "Safety Integrated" function in the Control Unit requires an acceptance test.</p> <p>Note:</p> <p>This fault results in a STOP A that can be acknowledged.</p> <p>Fault value (r0949, decimal):</p> <p>130: No safety parameters available for the Motor Module.</p> <p>1000: Reference and actual checksum on the Control Unit are not identical (booting).</p> <ul style="list-style-type: none"> <li>- at least one checksum-checked piece of data is defective.</li> </ul> <p>2000: Reference and actual checksum on the Control Unit are not identical (commissioning mode).</p> <ul style="list-style-type: none"> <li>- reference checksum incorrectly entered into the Control Unit (p9799 not equal to r9798).</li> </ul> <p>2001: Reference and actual checksum on the Motor Module are not identical (commissioning mode).</p> <ul style="list-style-type: none"> <li>- reference checksum incorrectly entered into the Motor Module (p9899 not equal to r9898).</li> </ul> <p>2002: Enable of safety-related functions between the Control Unit and Motor Module differ (p9601 not equal to p9801).</p> <p>2003: Acceptance test is required as a safety parameter has been changed.</p> <p>2004: An acceptance test is required because a project with enabled safety-functions has been downloaded.</p> <p>2010: Safe Brake Control is enabled differently between the Control Unit and Motor Module (p9602 not equal to p9802).</p> <p>2020: Error when saving the safety parameters for the Motor Module.</p> <p>9999: Subsequent response of another safety-related fault that occurred when booting that requires an acceptance test.</p>
<b>Remedy:</b>	<p>Re fault value = 130:</p> <ul style="list-style-type: none"> <li>- carry-out safety commissioning routine.</li> </ul> <p>Re fault value = 1000:</p> <ul style="list-style-type: none"> <li>- again carry-out safety commissioning routine.</li> <li>- replace the CompactFlash card.</li> </ul> <p>Re fault value = 2000:</p> <ul style="list-style-type: none"> <li>- check the safety parameters in the Control Unit and adapt the reference checksum (p9799).</li> </ul> <p>Re fault value = 2001:</p> <ul style="list-style-type: none"> <li>- check the safety parameters in the Motor Module and adapt the reference checksum (p9899).</li> </ul> <p>Re fault value = 2002:</p> <ul style="list-style-type: none"> <li>- enable the safety-related functions on the Control Unit and check on the Motor Module (p9601 = p9801).</li> </ul> <p>Re fault value = 2003, 2004:</p> <ul style="list-style-type: none"> <li>- Carry-out an acceptance test and generate an acceptance report. The procedure when carrying-out an acceptance test as well as an example of the acceptance report are provided in the documentation for SINAMICS Safety Integrated.</li> </ul> <p>Re fault value = 2010:</p> <ul style="list-style-type: none"> <li>- enable the Safe Brake Control in the Control Unit and check on the Motor Module (p9602 = p9802).</li> </ul> <p>Re fault value = 2020:</p> <ul style="list-style-type: none"> <li>- again carry-out safety commissioning routine.</li> <li>- replace the CompactFlash card.</li> </ul> <p>Re fault value = 9999:</p> <ul style="list-style-type: none"> <li>- carry-out diagnostics for the other safety-related fault that is present.</li> </ul> <p>Note:</p> <p>CU: Control Unit  MM: Motor Module  SI: Safety Integrated</p> <p>See also: p9799 (SI reference checksum SI parameters (Control Unit)), p9899 (SI reference checksum SI parameters (Motor Module))</p>

<b>F01651</b>	<b>SI CU: Synchronization safety time slices unsuccessful</b>
<b>Reaction:</b>	OFF2
<b>Acknowledge:</b>	IMMEDIATELY (POWER ON)
<b>Cause:</b>	The "Safety Integrated" function requires a synchronization of the safety time slices between the Control Unit (CU) and Motor Module (MM) and between the Control Unit and the higher-level control. This synchronization routine was not successful. Note: This fault results in a STOP A that cannot be acknowledged. Fault value (r0949, decimal): Only for internal Siemens troubleshooting.
<b>Remedy:</b>	- carry-out a POWER ON (power off/on) for all components. - upgrade the Motor Module software. - upgrade the Control Unit software. - upgrade the software of the higher-level control. Note: CU: Control Unit MM: Motor Module SI: Safety Integrated
<b>F01652</b>	<b>SI CU: Illegal monitoring clock cycle</b>
<b>Reaction:</b>	OFF2
<b>Acknowledge:</b>	IMMEDIATELY (POWER ON)
<b>Cause:</b>	One of the Safety Integrated monitoring clock cycles is not permissible: - the drive-based monitoring clock cycle cannot be maintained due to the communication conditions required in the system. - the monitoring clock cycle for safe motion monitoring functions with the higher-level control is not permissible (p9500). Note: This fault results in a STOP A that cannot be acknowledged. Fault value (r0949, decimal): - for enabled drive-based SI monitoring (p9601/p9801 > 0): Minimum setting for the monitoring clock cycle (in µs). - with the motion monitoring function enabled (p9501 > 0): 100: No matching monitoring clock cycle was able to be found. 101: The monitoring clock cycle is not an integer multiple of the position controller clock cycle. 102: An error has occurred when transferring the DP clock cycle to the Motor Module (MM). 103: An error has occurred when transferring the DP clock cycle to the Sensor Module.
<b>Remedy:</b>	For enabled drive-based SI monitoring (p9601/p9801 > 0): - upgrade the Control Unit software. For enabled motion monitoring function (p9501 > 0): - correct the monitoring clock cycle (p9500) and carry-out POWER ON. Note: CU: Control Unit MM: Motor Module SI: Safety Integrated

---

<b>F01655</b>	<b>SI CU: Align monitoring functions</b>
<b>Reaction:</b>	OFF2
<b>Acknowledge:</b>	IMMEDIATELY (POWER ON)
<b>Cause:</b>	<p>An error has occurred when aligning the Safety Integrated monitoring functions on the Control Unit (CU) and Motor Module (MM). Control unit and Motor Module were not able to determine a common set of supported SI monitoring functions.</p> <ul style="list-style-type: none"> <li>- there is either a DRIVE-CLIQ communications error or communications have failed.</li> <li>- Safety Integrated software releases on the Control Unit and Motor Module are not compatible with one another.</li> </ul> <p>Note: This fault results in a STOP A that cannot be acknowledged. Fault value (r0949, interpret hexadecimal): Only for internal Siemens troubleshooting.</p>
<b>Remedy:</b>	<ul style="list-style-type: none"> <li>- carry-out a POWER ON (power off/on) for all components.</li> <li>- upgrade the Motor Module software.</li> <li>- upgrade the Control Unit software.</li> <li>- check the electrical cabinet design and cable routing for EMC compliance</li> </ul> <p>Note: CU: Control Unit MM: Motor Module SI: Safety Integrated</p>

---

<b>F01656</b>	<b>SI CU: Motor Module parameter error</b>
<b>Reaction:</b>	OFF2
<b>Acknowledge:</b>	IMMEDIATELY (POWER ON)
<b>Cause:</b>	<p>When accessing the Safety Integrated parameters for the Motor Module (MM) on the CompactFlash card, an error has occurred.</p> <p>Note: This fault results in a STOP A that can be acknowledged. Fault value (r0949, decimal): 129: Safety parameters for the Motor Module corrupted. 131: Internal Motor Module software error. 132: Communication errors when uploading or downloading the safety parameters for the Motor Module. 255: Internal software error on the Control Unit.</p>
<b>Remedy:</b>	<ul style="list-style-type: none"> <li>- re-commission the safety functions.</li> <li>- upgrade the Control Unit software.</li> <li>- upgrade the Motor Module software.</li> <li>- replace the CompactFlash card.</li> </ul> <p>Re fault value = 132: - check the electrical cabinet design and cable routing for EMC compliance</p> <p>Note: CU: Control Unit MM: Motor Module SI: Safety Integrated</p>

<b>F01659</b>	<p><b>SI CU: Write request for parameter rejected</b></p> <p><b>Reaction:</b> OFF2</p> <p><b>Acknowledge:</b> IMMEDIATELY (POWER ON)</p> <p><b>Cause:</b> The write request for one or several Safety Integrated parameters on the Control Unit (CU) was rejected.</p> <p><b>Note:</b> This fault does not result in a safety stop response. Fault value (r0949, decimal): 1: The Safety Integrated password is not set. 2: It was selected that the drive parameters are reset. However, the Safety Integrated parameters cannot be reset, as Safety Integrated is presently enabled. 3: The interlocked SH input is in the simulation mode. 10: An attempt was made to enable the SH function although this cannot be supported. 11: An attempt was made to enable the SBC function although this cannot be supported. 12: An attempt was made to enable the SBC function although this cannot be supported for a parallel circuit configuration. 13: An attempt was made to enable the SS1 function although this cannot be supported. 14: An attempt was made to enable the PROFIsafe communications although this cannot be supported. 15: An attempt was made to enable the motion monitoring functions integrated in the drive although these cannot be supported. 16: An attempt was made to enable the SH function although this cannot be supported when the internal voltage protection (p1231) is enabled. See also: p0970 (Reset infeed parameter), p3900 (Completion of quick commissioning), r9771 (SI common functions (Control Unit)), r9871 (SI common functions (Motor Module))</p> <p><b>Remedy:</b> Re fault value = 1: - set the Safety Integrated password (p9761). Re fault value = 2: - inhibit Safety Integrated and again reset the drive parameters. Re fault value = 3: - simulation mode for the digital input has ended (p0795). Re fault value = 10, 11, 12, 13, 14, 15: - check whether there are faults in the safety function alignment between the Control Unit and the Motor Module involved (F01655, F30655) and if required, carry-out diagnostics for the faults involved. - use a Motor Module that supports the required function ("safe standstill", "Safe Brake Control", "PROFIsafe", "motion monitoring functions integrated in the drive"). - upgrade the Motor Module software. - upgrade the Control Unit software. Re fault value = 16: - inhibit the internal voltage protection (p1231). <b>Note:</b> CU: Control Unit SBC: Safe Brake Control SH: Safe standstill SI: Safety Integrated SS1: Safe Stop 1 (corresponds to Stop Category 1 acc. to EN60204) See also: p9501 (SI motion enable safety-relevant functions), p9601 (SI enable, functions integrated in the drive (Control Unit)), p9620 (SI signal source for SH/SBC/SS1 (Control Unit)), p9761 (SI password input), p9801 (SI enable, functions integrated in the drive (Motor Module))</p>
<b>F01660</b>	<p><b>SI CU: Safety-related functions not supported</b></p> <p><b>Reaction:</b> OFF2</p> <p><b>Acknowledge:</b> IMMEDIATELY (POWER ON)</p> <p><b>Cause:</b> The Motor Module (MM) does not support the safety-related functions (e.g. the Motor Module version is not the correct one). Safety Integrated cannot be commissioned.</p> <p><b>Note:</b> This fault results in a STOP A that cannot be acknowledged.</p> <p><b>Remedy:</b> - use a Motor Module that supports the safety-related functions. - upgrade the Motor Module software. <b>Note:</b> CU: Control Unit MM: Motor Module SI: Safety Integrated</p>

---

<b>F01670</b>	<b>SI Motion: Invalid parameterization, Sensor Module</b>
<b>Reaction:</b>	OFF2
<b>Acknowledge:</b>	IMMEDIATELY (POWER ON)
<b>Cause:</b>	The parameterization of a Sensor Module used for Safety Integrated is not permissible. Note: This fault results in a STOP A that cannot be acknowledged. Fault value (r0949, decimal): 1: No encoder was parameterized for Safety Integrated. 2: An encoder was parameterized for Safety Integrated that does not have an A/B track (sinusoidal/cosinusoidal). 3: The encoder data set selected for Safety Integrated is still not valid. 4: A communications error to the encoder has occurred. 10: For an encoder used for Safety Integrated, not all of the Drive Data Sets (DDS) are assigned to the same Encoder Data Set (EDS) (p0187 ... p0189).
<b>Remedy:</b>	Re fault value = 1, 2: - use and parameterize an encoder that Safety Integrated supports (encoder with track A/B sinusoidal, p0404.4 = 1). Re fault value = 3: - check whether the drive or drive commissioning function is active and if required, exit this (p0009 = p00010 = 0), save the parameters (p0971 = 1) and carry-out a POWER ON Re fault value = 4: - check whether there is a DRIVE-CLiQ communications error between the Control Unit and the Sensor Module involved and if required, carry-out a diagnostics routine for the faults identified. Re fault value = 10: - align the EDS assignment of all of the encoders used for safety integrated (p0187 ... p0189). Note: SI: Safety Integrated

---

<b>F01671</b>	<b>SI Motion: Parameterization error, encoder</b>
<b>Reaction:</b>	OFF2
<b>Acknowledge:</b>	IMMEDIATELY (POWER ON)
<b>Cause:</b>	The parameterization of the encoder used by Safety Integrated is different than the parameterization of the standard encoder. Fault value (r0949, decimal): Parameter number of the non-corresponding safety parameter.
<b>Remedy:</b>	Align the encoder parameterization between the safety encoder and the standard encoder. Note: SI: Safety Integrated

---

<b>F01672</b>	<b>SI Motion: Motor Module software incompatible</b>
<b>Reaction:</b>	OFF2
<b>Acknowledge:</b>	IMMEDIATELY (POWER ON)
<b>Cause:</b>	The existing Motor Module software does not support the safe motion monitoring function with the higher-level control. Note: This fault results in a STOP A that cannot be acknowledged. Fault value (r0949, decimal): Only for internal Siemens troubleshooting.
<b>Remedy:</b>	- check whether there are faults in the safety function alignment between the Control Unit and the Motor Module involved (F01655, F30655) and if required, carry-out the appropriate diagnostics routine for the particular faults. - use a Motor Module that supports safe motion monitoring - upgrade the Motor Module software. Note: SI: Safety Integrated

<b>F01673</b>	<b>SI Motion: Sensor Module software incompatible</b>
<b>Reaction:</b>	OFF2
<b>Acknowledge:</b>	IMMEDIATELY (POWER ON)
<b>Cause:</b>	The existing Sensor Module software does not support the safe motion monitoring function with the higher-level control. Note: This fault results in a STOP A that cannot be acknowledged. Fault value (r0949, decimal): Only for internal Siemens troubleshooting.
<b>Remedy:</b>	- use a Sensor Module that supports safe motion monitoring function. - upgrade the Sensor Module software. Note: SI: Safety Integrated
<b>F01680</b>	<b>SI Motion: Checksum error, safety monitoring functions</b>
<b>Reaction:</b>	OFF2
<b>Acknowledge:</b>	IMMEDIATELY (POWER ON)
<b>Cause:</b>	The actual checksum calculated by the drive and entered in r9728 over the safety-relevant parameters does not match the target checksum saved in p9729 at the last machine acceptance. Safety-relevant parameters have been changed or a fault is present. Note: This fault results in a STOP A that cannot be acknowledged. Fault value (r0949, decimal): 0: Checksum error for SI parameters for motion monitoring. 1: Checksum error for SI parameters for actual values.
<b>Remedy:</b>	- Check the safety-relevant parameters and if required, correct. - carry-out a POWER ON. - carry-out an acceptance test. Note: SI: Safety Integrated
<b>C01681</b>	<b>SI Motion: Incorrect parameter value</b>
<b>Reaction:</b>	NONE
<b>Acknowledge:</b>	IMMEDIATELY (POWER ON)
<b>Cause:</b>	The parameter value cannot be parameterized with this value. Fault value (r0949, decimal): Parameter number with the incorrect value
<b>Remedy:</b>	Correct parameter value
<b>F01682</b>	<b>SI Motion: Monitoring function not supported</b>
<b>Reaction:</b>	OFF2
<b>Acknowledge:</b>	IMMEDIATELY (POWER ON)
<b>Cause:</b>	The monitoring function enabled in p9501, p9601 or p9801 is not supported in this firmware version. Note: This fault results in a STOP A that cannot be acknowledged. Fault value (r0949, decimal): 1: Monitoring function SE not supported (p9501.1). 2: Monitoring function SN not supported (p9501.7 and p9501.8 - 15 and p9503). 3: Monitoring function SG override not supported (p9501.5). 10: Monitoring functions only supported in the servo mode. 20: Drive-based motion monitoring functions are only supported in conjunction with PROFIsafe (p9501 and p9601.1 - 2 and p9801.1 - 2). 21: PROFIsafe only supported in conjunction with motion monitoring functions in the drive (p9501 and p9601.1 - 2 and p9801.1 - 2).
<b>Remedy:</b>	De-select the monitoring function involved (p9501, p9503, p9601, p9801). Note: SE: Safe software limit switch, SG: Safely-reduced speed SI: Safety Integrated SN: Safe software cam See also: p9501 (SI motion enable safety-relevant functions)



---

<b>F01683</b>	<b>SI Motion: SBH/SG enable missing</b>
<b>Reaction:</b>	OFF2
<b>Acknowledge:</b>	IMMEDIATELY (POWER ON)
<b>Cause:</b>	The safety-relevant basic function "SBH/SG" is not enabled in p9501 although other safety-relevant monitoring functions are enabled. Note: This fault results in a STOP A that cannot be acknowledged.
<b>Remedy:</b>	Enable the function "SBH/SG" (p9501.0) and carry-out a POWER ON. Note: SBH: Safe operating stop SG: Safely-reduced speed SI: Safety Integrated See also: p9501 (SI motion enable safety-relevant functions)

---

<b>F01684</b>	<b>SI Motion: Safe software limit switch limit values interchanged</b>
<b>Reaction:</b>	OFF2
<b>Acknowledge:</b>	IMMEDIATELY (POWER ON)
<b>Cause:</b>	For the function "safe software limit switch" (SE), a lower value is in p9534 as in p9535. Note: This fault results in a STOP A that cannot be acknowledged. Fault value (r0949, decimal): 1: Limit values SE1 interchanged. 2: Limit values SE2 interchanged.
<b>Remedy:</b>	Correct the limit values in p9534 and p9535 and carry-out a POWER ON. Note: SE: Safe software limit switch SI: Safety Integrated

---

<b>F01685</b>	<b>SI Motion: Safe velocity limit value too high</b>
<b>Reaction:</b>	OFF2
<b>Acknowledge:</b>	IMMEDIATELY (POWER ON)
<b>Cause:</b>	The limit value for the function "safely reduced speed" (SG) is greater than the speed that corresponds to an encoder limit frequency of 500 kHz. Fault value (r0949, decimal): Maximum permissible speed.
<b>Remedy:</b>	Correct the limit values for SG and carry-out a POWER ON. Note: SG: Safely-reduced speed SI: Safety Integrated See also: p9531 (SI motion SG limit values)

---

<b>F01686</b>	<b>SI Motion: Illegal parameterization, cam position</b>
<b>Reaction:</b>	OFF2
<b>Acknowledge:</b>	IMMEDIATELY (POWER ON)
<b>Cause:</b>	At least one enabled "safety software cam" (SN) is parameterized in p9536 or p9537 too close at the tolerance range around the modulo position. Fault value (r0949, decimal): Number of the "safe software cam" with an illegal position. See also: p9501 (SI motion enable safety-relevant functions)
<b>Remedy:</b>	Correct the cam position and carry-out a POWER ON. Note: SI: Safety Integrated SN: Safe software cam See also: p9536 (SI motion SN plus cam position), p9537 (SI motion SN minus cam position)

<b>F01687</b>	<b>SI Motion: Illegal parameterization, modulo value SN</b>
<b>Reaction:</b>	OFF2
<b>Acknowledge:</b>	IMMEDIATELY (POWER ON)
<b>Cause:</b>	The parameterized modulo value for the "safe software cam" (SN) function is not a multiple of 360 000 mDegrees.
<b>Remedy:</b>	Correct the modulo value for SN and carry-out a POWER ON. Note: SI: Safety Integrated SN: Safe software cam See also: p9505 (SI motion SN modulo value)
<b>F01688</b>	<b>SI Motion: Actual value synchronization not permissible</b>
<b>Reaction:</b>	OFF2
<b>Acknowledge:</b>	IMMEDIATELY (POWER ON)
<b>Cause:</b>	It is not permissible to simultaneously enable the actual value synchronization and a monitoring function with absolute reference (SE/SN).
<b>Remedy:</b>	Either carry-out the monitoring functions with absolute reference (SE/SN) or de-select the "actual value synchronization" function and carry-out a POWER ON. Note: SE: Safe software limit switch SI: Safety Integrated SN: Safe software cam See also: p9501 (SI motion enable safety-relevant functions)
<b>C01689</b>	<b>SI Motion: Axis re-configured</b>
<b>Reaction:</b>	OFF2
<b>Acknowledge:</b>	POWER ON
<b>Cause:</b>	The axis configuration was changed. Parameter p0108.13 is internally set to the correct value. Fault value (r0949, decimal): Parameter number that initiated the change. See also: p9502 (SI motion axis type)
<b>Remedy:</b>	Initiate data back-up on the complete Control Unit and carry-out a POWER ON.
<b>A01698 (F)</b>	<b>SI CU: Commissioning mode active</b>
<b>Reaction:</b>	NONE
<b>Acknowledge:</b>	NONE
<b>Cause:</b>	The commissioning of the "Safety Integrated" function is selected. This message is withdrawn after the safety functions have been commissioned. Note: This message does not result in a safety stop response. See also: p0010 (Infeed commissioning parameter filter)
<b>Remedy:</b>	None necessary. Note: CU: Control Unit SI: Safety Integrated
Reaction upon F:	NONE (OFF1, OFF2, OFF3)
Acknowledge upon F:	IMMEDIATELY (POWER ON)

---

<b>A01699 (F)</b>	<b>SI CU: Shutdown path must be tested</b>
<b>Reaction:</b>	NONE
<b>Acknowledge:</b>	NONE
<b>Cause:</b>	The time set in p9659 for the forced checking procedure of the safety shutdown paths has been exceeded. The safety shutdown paths must be re-tested. After the next time that the "safe standstill" function (SH) is de-selected, the message is withdrawn and the monitoring time is reset. Note: This message does not result in a safety stop response. See also: p9659 (SI forced checking procedure timer)
<b>Remedy:</b>	Select safe standstill and then deselect again. Note: CU: Control Unit SH: Safe standstill SI: Safety Integrated
Reaction upon F:	NONE (OFF1, OFF2, OFF3)
Acknowledge upon F:	IMMEDIATELY (POWER ON)

---

<b>C01700</b>	<b>SI Motion: STOP A initiated</b>
<b>Reaction:</b>	OFF2
<b>Acknowledge:</b>	IMMEDIATELY (POWER ON)
<b>Cause:</b>	The drive is stopped via a STOP A (pulses are cancelled via the safety shutdown path of the Control Unit). Possible causes: - stop request from the higher-level control. - pulses not cancelled after a parameterized time (p9557) after test stop selection. - subsequent response to the message C01706 "SI Motion: Safe braking ramp exceeded". - subsequent response to the message C01714 "SI Motion: Safely reduced speed exceeded". - subsequent response to the message C01701 "SI Motion: STOP B initiated".
<b>Remedy:</b>	- remove the fault cause in the control and carry-out a POWER ON. - check the value in p9557, if necessary, increase the value, and carry-out POWER ON. - check the shutdown path of Control Unit (check DRIVE-CLiQ communications). - carry-out a diagnostics routine for message C01706. - carry-out a diagnostics routine for message C01714. - carry-out a diagnostics routine for message C01701. - replace Motor Module. - replace Control Unit. Note: SI: Safety Integrated

---

<b>C01701</b>	<b>SI Motion: STOP B initiated</b>
<b>Reaction:</b>	OFF3
<b>Acknowledge:</b>	IMMEDIATELY (POWER ON)
<b>Cause:</b>	The drive is stopped via a STOP B (braked along the current limit). As a result of this fault, after the time, parameterized in p9556 has expired, or the speed threshold, parameterized in p9560 has been fallen below, message C01700 "STOP A initiated" is output. Possible causes: - stop request from the higher-level control. - subsequent response to the message C01714 "SI Motion: Safely reduced speed exceeded". - subsequent response to the message C01711 "SI Motion: Defect in a monitoring channel".
<b>Remedy:</b>	- remove the fault cause in the control and carry-out a POWER ON. - carry-out a diagnostics routine for message C01714. - carry-out a diagnostics routine for message C01711. Note: SI: Safety Integrated

<b>C01706</b>	<b>SI Motion: Safe braking ramp exceeded</b>
<b>Reaction:</b>	NONE
<b>Acknowledge:</b>	IMMEDIATELY (POWER ON)
<b>Cause:</b>	After initiating STOP B or STOP C, the velocity has exceeded the selected tolerance. The drive is shut down by the message C01700 "SI Motion: STOP A initiated".
<b>Remedy:</b>	Check the braking behavior, if required, adapt the tolerance for "safe braking ramp" (SBR). Note: SBR: Safe braking ramp SI: Safety Integrated See also: p9548 (SI motion SBR actual speed tolerance)
<b>C01707</b>	<b>SI Motion: Tolerance for safe operating stop exceeded</b>
<b>Reaction:</b>	NONE
<b>Acknowledge:</b>	IMMEDIATELY (POWER ON)
<b>Cause:</b>	The actual position has distanced itself further from the target position than the standstill tolerance. The drive is shut down by the message C01701 "SI Motion: STOP B initiated".
<b>Remedy:</b>	- check whether safety faults are present and if required carry-out the appropriate diagnostic routines for the particular faults. - check whether the standstill tolerance matches the accuracy and control dynamic performance of the axis. - carry-out a POWER ON. Note: SBH: Safe operating stop SI: Safety Integrated See also: p9530 (SI motion standstill tolerance)
<b>C01708</b>	<b>SI Motion: STOP C initiated</b>
<b>Reaction:</b>	STOP2
<b>Acknowledge:</b>	IMMEDIATELY (POWER ON)
<b>Cause:</b>	The drive is stopped via a STOP C (braked along the current limit). "Safe operating stop" (SBH) is activated after the parameterized timer stage has expired. Possible causes: - stop request from the higher-level control. - subsequent response to the message C01714 "SI Motion: Safely reduced speed exceeded". - subsequent response to the message C01715 "SI Motion: Safe end stop exceeded". See also: p9552 (SI motion transition time STOP C to SBH)
<b>Remedy:</b>	- remove the fault cause in the control and carry-out a POWER ON. - carry-out a diagnostics routine for message C01714. Note: SBH: Safe operating stop SI: Safety Integrated
<b>C01709</b>	<b>SI Motion: STOP D initiated</b>
<b>Reaction:</b>	NONE
<b>Acknowledge:</b>	IMMEDIATELY (POWER ON)
<b>Cause:</b>	The drive is stopped via a STOP D (braking along the path). "Safe operating stop" (SBH) is activated after the parameterized timer stage has expired. Possible causes: - stop request from the higher-level control. - subsequent response to the message C01714 "SI Motion: Safely reduced speed exceeded". - subsequent response to the message C01715 "SI Motion: Safe end stop exceeded". See also: p9553 (SI motion transition time STOP D to SBH)
<b>Remedy:</b>	- remove the fault cause in the control and carry-out a POWER ON. - carry-out a diagnostics routine for message C01714. Note: SBH: Safe operating stop SI: Safety Integrated

<b>C01710</b>	<b>SI Motion: STOP E initiated</b>
<b>Reaction:</b>	NONE
<b>Acknowledge:</b>	IMMEDIATELY (POWER ON)
<b>Cause:</b>	The drive is stopped via a STOP E (retraction motion). "Safe operating stop" (SBH) is activated after the parameterized timer stage has expired. Possible causes: - stop request from the higher-level control. - subsequent response to the message C01714 "SI Motion: Safely reduced speed exceeded". - subsequent response to the message C01715 "SI Motion: Safe end stop exceeded". See also: p9554 (SI motion transition time STOP E to SBH)
<b>Remedy:</b>	- remove the fault cause in the control and carry-out a POWER ON. - carry-out a diagnostics routine for message C01714. Note: SBH: Safe operating stop SI: Safety Integrated
<b>C01711</b>	<b>SI Motion: Defect in a monitoring channel"</b>
<b>Reaction:</b>	NONE
<b>Acknowledge:</b>	IMMEDIATELY (POWER ON)
<b>Cause:</b>	When cross-checking and comparing the two monitoring channels, the drive detected a difference between the input data or results of the monitoring functions and initiated a STOP F. One of the monitoring function functions no longer reliably functions - i.e. safe operation is no longer possible. If at least one monitoring function is active, then after the parameterized timer stage has expired, the message C01701 "SI Motion: STOP B initiated" is output. The message value that resulted in a STOP F is displayed in r9725. Message value (r9749, decimal): Value, that resulted in a STOP F. See also: p9555 (SI motion transition time STOP F to STOP B), r9725 (SI motion, diagnostics STOP F)
<b>Remedy:</b>	The message value contained in r9725 is described in message 27001 of the higher-level control. Note: SI: Safety Integrated
<b>C01714</b>	<b>SI Motion: Safely reduced speed exceeded</b>
<b>Reaction:</b>	NONE
<b>Acknowledge:</b>	IMMEDIATELY (POWER ON)
<b>Cause:</b>	The drive had moved faster than that specified by the velocity limit value (p9531). The drive is stopped as a result of the configured stop response (p9563). Message value (r9749, decimal): 100: SG1 exceeded. 200: SG2 exceeded.. 300: SG3 exceeded. 400: SG4 exceeded. 1000: Encoder limit frequency exceeded.
<b>Remedy:</b>	- check the traversing/motion program in the control. - check the limits for "safely reduced speed (SG) and if required, adapt (p9531). Note: SG: Safely-reduced speed SI: Safety Integrated See also: p9531 (SI motion SG limit values), p9563 (SI motion SG-specific stop response)

---

<b>A01796 (F, N)</b>	<b>SI Motion: Wait for communications to the control</b>
<b>Reaction:</b>	NONE
<b>Acknowledge:</b>	NONE
<b>Cause:</b>	The drive waits for communications to be established with the higher-level control to execute the safety-relevant motion monitoring functions. Note: In this state, the pulses are safely deleted.
<b>Remedy:</b>	If, after a longer period of time, the message is not automatically withdrawn, then the following checks are made: - correct assignment of the axes on the higher-level control to the drives in the drive unit. - enable signal of the safety-relevant motion monitoring functions for the corresponding axis on the higher-level control.
Reaction upon F:	NONE (OFF1, OFF2, OFF3)
Acknowledge upon F:	IMMEDIATELY
Reaction upon N:	NONE
Acknowledge upon N:	NONE

---

<b>C01798</b>	<b>SI Motion: Test stop running</b>
<b>Reaction:</b>	NONE
<b>Acknowledge:</b>	IMMEDIATELY (POWER ON)
<b>Cause:</b>	The test stop is active.
<b>Remedy:</b>	None necessary. The message is withdrawn when the test stop is ended. Note: SI: Safety Integrated

---

<b>C01799</b>	<b>SI Motion: Acceptance test mode active</b>
<b>Reaction:</b>	NONE
<b>Acknowledge:</b>	IMMEDIATELY (POWER ON)
<b>Cause:</b>	The acceptance test mode is active. The POWER ON signals of the safety-relevant motion monitoring functions can be acknowledged during the acceptance test using the RESET button of the higher-level control.
<b>Remedy:</b>	None necessary. The message is withdrawn when exiting the acceptance test mode. Note: SI: Safety Integrated

<b>F01800</b>	<b>DRIVE-CLiQ: Hardware/configuration error</b>
<b>Reaction:</b>	A_INFEED: NONE (OFF1, OFF2) SERVO: NONE (DCBRAKE, ENCODER, OFF1, OFF2, OFF3, STOP1, STOP2) VECTOR: NONE (DCBRAKE, ENCODER, OFF1, OFF2, OFF3, STOP1, STOP2)
<b>Acknowledge:</b>	IMMEDIATELY (POWER ON)
<b>Cause:</b>	A DRIVE-CLiQ connection fault has occurred. Fault value (r0949, decimal): 0 ... 7: Communications via DRIVE-CLiQ socket 0 ... 7 has not been switched to cyclic operation. The cause can be an incorrect structure or a configuration that results in an impossible bus timing. 10: Loss of the DRIVE-CLiQ connection. The cause can be, for example, that the DRIVE-CLiQ cable was withdrawn from the Control Unit or as a result of a short-circuit for motors with DRIVE-CLiQ. This fault can only be acknowledged in cyclic communication. 11: Repeated fault when detecting the connection. This fault can only be acknowledged in cyclic communication. 12: A connection was detected but the node ID exchange mechanism does not function. The reason is probably that the component is defective. This fault can only be acknowledged in cyclic communication.
<b>Remedy:</b>	Re fault value = 0 ... 7: - ensure that the DRIVE-CLiQ components have the same firmware releases. - avoid longer topologies for short current controller clock cycles. Re fault value = 10: - check the DRIVE-CLiQ cables at the Control Unit. - remove any short-circuit for motors with DRIVE-CLiQ. - carry-out a POWER ON. Re fault value = 11: - check the electrical cabinet design and cable routing for EMC compliance Re fault value = 12: - replace the component involved.
<b>F01802 (A)</b>	<b>CU DRIVE-CLiQ: POWER ON due to basis sampling times</b>
<b>Reaction:</b>	A_INFEED: OFF2 (OFF1) SERVO: OFF2 (DCBRAKE, OFF1) VECTOR: OFF2 (DCBRAKE, OFF1)
<b>Acknowledge:</b>	POWER ON
<b>Cause:</b>	It is not possible to change the DRIVE-CLiQ basic sampling times p0110 in operation. POWER ON is required. Fault value (r0949, decimal): Index of p0110.
<b>Remedy:</b>	- save (p0971 = 1). - carry-out a POWER ON.
Reaction upon A:	NONE
Acknowledge upon A:	NONE
<b>A01900 (F)</b>	<b>PROFIBUS: Configuration telegram error</b>
<b>Reaction:</b>	NONE
<b>Acknowledge:</b>	NONE
<b>Cause:</b>	A PROFIBUS master attempts to establish a connection using an incorrect configuring telegram. Alarm value (r2124, decimal): 50: Syntax error. 51: Connection established to more drive objects than configured in the device. The drive objects for process data exchange and their sequence was defined using p0978. 52: Too many data words for input or output to a drive object. A max. of 16 words is permitted for SERVO and VECTOR; max. 5 words, for A_INFEED, TB30, TM31 and CU320. 53: Uneven number of bytes for input or output.
<b>Remedy:</b>	Check the bus configuring on the master and slave sides. Re alarm value = 51: Check the list of the drive objects with process data exchange (p0978). With p0978[x] = 0, all of the following drive objects in the list are excluded from the process data exchange.

Reaction upon F: NONE (OFF1)  
 Acknowledge upon F: IMMEDIATELY

---

**A01901 (F) PROFIBUS: Parameterizing telegram error**

**Reaction:** NONE  
**Acknowledge:** NONE  
**Cause:** A PROFIBUS master attempts to establish a connection using an incorrect parameterizing telegram.  
 Alarm value (r2124, decimal):  
 1: Incorrect parameterizing bits  
 10: Illegal length of an optional parameterizing block  
 11: Illegal ID of an optional parameterizing block  
 20: Double parameterizing block for clock synchronization  
 21: Incorrect parameterizing block for clock synchronization  
 22: Incorrect parameterizing bits for clock synchronization

**Remedy:** Check the bus configuration:  
 - bus addresses  
 - slave configuring

Reaction upon F: NONE (OFF1)  
 Acknowledge upon F: IMMEDIATELY

---

**A01902 PROFIBUS: Illegal parameterizing telegram**

**Reaction:** NONE  
**Acknowledge:** NONE  
**Cause:** Alarm value (r2124, decimal):  
 0: Bus cycle time  $T_{dp} < 0.5$  ms.  
 1: Bus cycle time  $T_{dp} > 32$  ms.  
 2: Bus cycle time  $T_{dp}$  is not a integer multiple of the current controller clock cycle.  
 3: Instant of the actual value sensing  $T_i > \text{Bus cycle time } T_{dp}$ .  
 4: Instant of the actual value sensing  $T_i$  is not an integer multiple of the current controller clock cycle.  
 5: Instant of the setpoint transfer  $T_o \geq \text{Bus cycle time } T_{dp}$ .  
 6: Instant of the setpoint transfer  $T_o$  is not an integer multiple of the current controller clock cycle.  
 7: Master application cycle time  $T_{mapc}$  is not an integer multiple of the speed controller clock cycle.  
 8: Bus reserve bus cycle time  $T_{dp}$  - data exchange time  $T_{dx}$  less than two current controller clock cycles.  
 9: Bus cycle time  $T_{dp}$  has been modified with respect to the first time that the connection was established.  
 10: Instant of the setpoint transfer not  $T_o \leq \text{data exchange time } T_{dx} + T_{o\_min}$ .  
 11: Master application cycle time  $T_{mapc} > 14$ .  
 12: PLL tolerance window  $T_{pll\_w} > T_{pll\_w\_max}$ .  
 13: Bus cycle time  $T_{dp}$  is not a multiple of all basic clock cycles  $p0110[x]$ .  
 14: For COMM BOARD with the setting  $T_o - 1 = T_{dp} - T_i$ , the instant of the setpoint transfer is not  $T_o \leq \text{Data Exchange time } T_{dx} + 2 * T_{o\_min}$ .  
 15: This configuration is not permitted for  $T_{dp} < 1$  ms.  
 16: Instant of the actual value sensing  $T_i$  is less than the permitted value (COMM BOARD:  $T_i \geq 2$ ).  
 17: The setting  $(T_o + T_i = T_{dp} + 2)$  is not permitted for COMM BOARD.

**Remedy:**  
 - adapt the parameterizing telegram.  
 - adapt the current and speed controller clock cycle.  
 Re alarm value = 9:  
 - carry-out a POWER ON.  
 Re alarm value = 15:  
 - check the number of specific drive object types in the configuration.



<b>A01903 (F)</b>	<b>COMM INT: Receive configuration data invalid</b>
<b>Reaction:</b>	NONE
<b>Acknowledge:</b>	NONE
<b>Cause:</b>	The drive unit did not accept the receive-configuration data. Alarm value (r2124, decimal): Return value of the receive-configuration data check. 0: Configuration accepted. 1: Connection established to more drive objects than configured in the device. The drive objects for process data exchange and their sequence was defined using p0978. 2: Too many data words for input or output to a drive object. A max. of 16 words is permitted for SERVO and VECTOR; max. 5 words, for A_INFEED, TB30, TM31 and CU320. 3: Uneven number of bytes for input or output. 4: Setting data for synchronization not accepted. 5: Drive still not in cyclic operation. 6: Buffer system not accepted. 7: Cyclic channel length too short for this setting. 8: Cyclic channel address not initialized. 9: 3-buffer system not permitted. 10: DRIVE-CLiQ fault. 11: CU link fault. 12: CX32 not in cyclic operation.
<b>Remedy:</b>	Check the receive configuration data. Re alarm value = 1: Check the list of the drive objects with process data exchange (p0978). With p0978[x] = 0, all of the following drive objects in the list are excluded from the process data exchange.
Reaction upon F:	A_INFEED: NONE (OFF1, OFF2) SERVO: NONE (OFF1, OFF2, OFF3) VECTOR: NONE (OFF1, OFF2, OFF3)
Acknowledge upon F:	IMMEDIATELY
<b>F01910 (N, A)</b>	<b>PROFIBUS: Setpoint timeout</b>
<b>Reaction:</b>	A_INFEED: OFF2 (NONE, OFF1) SERVO: OFF3 (DCBRAKE, NONE, OFF1, OFF2, STOP1, STOP2) VECTOR: OFF3 (DCBRAKE, NONE, OFF1, OFF2, STOP1, STOP2)
<b>Acknowledge:</b>	IMMEDIATELY
<b>Cause:</b>	The receipt of setpoints from the PROFIBUS interface is interrupted because the bus connection is interrupted or the PROFIBUS master is switched off or was set into the STOP state.
<b>Remedy:</b>	Restore the bus connection and set the PROFIBUS master to RUN.
Reaction upon N:	NONE
Acknowledge upon N:	NONE
Reaction upon A:	NONE
Acknowledge upon A:	NONE
<b>F01911</b>	<b>PROFIBUS: Clock synchronous operation, clock cycle failure</b>
<b>Reaction:</b>	OFF1
<b>Acknowledge:</b>	IMMEDIATELY
<b>Cause:</b>	The global control telegram to synchronize the clock cycles has failed - in cyclic operation - for several DP clock cycles or has violated the time grid specified in the parameterizing telegram over several consecutive DP clock cycles (refer to the bus cycle time, Tdp and Tdplw).
<b>Remedy:</b>	- check the PROFIBUS cables and connectors. - check whether communications were briefly or permanently interrupted. - check the bus and master for utilization level (e.g. bus cycle time Tdp was set too short).

<b>F01912</b>	<b>PROFIBUS: Clock synchronous operation sign-of-life missing</b>
<b>Reaction:</b>	OFF1
<b>Acknowledge:</b>	IMMEDIATELY
<b>Cause:</b>	The maximum permissible number of errors in the master sign-of-life (clock synchronous PROFIBUS) has been exceeded in cyclic operation.
<b>Remedy:</b>	<ul style="list-style-type: none"> <li>- check the physical bus configuration (terminating resistor, shielding, etc.).</li> <li>- check the interconnection of the master sign-of-life (p2045).</li> <li>- check whether the master correctly sends the sign-of-life (e.g. set-up a trace with STW2.12 ... STW2.15 and trigger signal ZSW1.3).</li> <li>- check the permissible telegram failure rate (p0925).</li> <li>- check the bus and master for utilization level (e.g. bus cycle time Tdp was set too short).</li> </ul>
<b>F01913 (N, A)</b>	<b>COMM INT: Monitoring time, sign-of-life expired</b>
<b>Reaction:</b>	A_INFEED: OFF1 (NONE, OFF2) SERVO: OFF1 (NONE, OFF2, OFF3) VECTOR: OFF1 (NONE, OFF2, OFF3)
<b>Acknowledge:</b>	IMMEDIATELY
<b>Cause:</b>	The monitoring time for the sign-of-life counter has expired.
<b>Remedy:</b>	<ul style="list-style-type: none"> <li>- acknowledge faults that are present.</li> <li>- carry-out a POWER ON (power off/on) for all components.</li> <li>- upgrade the firmware release.</li> <li>- contact the Hotline.</li> </ul>
Reaction upon N:	NONE
Acknowledge upon N:	NONE
Reaction upon A:	NONE
Acknowledge upon A:	NONE
<b>F01914 (N, A)</b>	<b>COMM INT: Monitoring time, configuration expired</b>
<b>Reaction:</b>	A_INFEED: OFF1 (NONE, OFF2) SERVO: OFF1 (NONE, OFF2, OFF3) VECTOR: OFF1 (NONE, OFF2, OFF3)
<b>Acknowledge:</b>	IMMEDIATELY
<b>Cause:</b>	The monitoring time for the configuration has expired. Fault value (r0949, decimal): 0: The transfer of the send-configuration data has been exceeded (time). 1: The transfer of the receive-configuration data has been exceeded (time).
<b>Remedy:</b>	<ul style="list-style-type: none"> <li>- acknowledge faults that are present.</li> <li>- carry-out a POWER ON (power off/on) for all components.</li> <li>- upgrade the firmware release.</li> <li>- contact the Hotline.</li> </ul>
Reaction upon N:	NONE
Acknowledge upon N:	NONE
Reaction upon A:	NONE
Acknowledge upon A:	NONE
<b>A01920 (F)</b>	<b>PROFIBUS: Interruption, cyclic connection</b>
<b>Reaction:</b>	NONE
<b>Acknowledge:</b>	NONE
<b>Cause:</b>	The cyclic connection to the PROFIBUS master is interrupted.
<b>Remedy:</b>	Set up the PROFIBUS connection and activate the PROFIBUS master in the cyclic mode.
Reaction upon F:	NONE (OFF1)
Acknowledge upon F:	IMMEDIATELY

<b>A01921 (F)</b>	<b>PROFIBUS: Clock cycle synchronization</b>
<b>Reaction:</b>	NONE
<b>Acknowledge:</b>	NONE
<b>Cause:</b>	Output data of PROFIBUS master (setpoints) received at the incorrect instant in time within the PROFIBUS clock cycle.
<b>Remedy:</b>	Check the bus configuration: - parameter for clock cycle synchronization: Ensure the instant in time for setpoint acceptance $T_o >$ data exchange time $T_{dx}$
Reaction upon F:	NONE (OFF1)
Acknowledge upon F:	IMMEDIATELY
<b>A01930</b>	<b>PROFIBUS: Current controller clock cycle for clock synchronous operation not the same</b>
<b>Reaction:</b>	NONE
<b>Acknowledge:</b>	NONE
<b>Cause:</b>	The current controller clock cycle of all drives must be set the same for the clock synchronous PROFIBUS. Alarm value (r2124, decimal): Number of the drive object with the different current controller clock cycle.
<b>Remedy:</b>	- set current controller clock cycles to identical values (p0115[0]). See also: p0115 (Sampling time for supplementary functions)
<b>A01931</b>	<b>PROFIBUS: Speed controller clock cycle for clock synchronous operation not the same</b>
<b>Reaction:</b>	NONE
<b>Acknowledge:</b>	NONE
<b>Cause:</b>	The speed controller clock cycle of all drives must be set the same for the clock synchronous PROFIBUS. Alarm value (r2124, decimal): Number of the drive object with the different speed controller clock cycle.
<b>Remedy:</b>	- set the speed controller clock cycles the same (p0115[1]). See also: p0115 (Sampling time for supplementary functions)
<b>A01940</b>	<b>PROFIBUS: Clock cycle synchronism not reached</b>
<b>Reaction:</b>	NONE
<b>Acknowledge:</b>	NONE
<b>Cause:</b>	PROFIBUS is in the data exchange state and clock synchronous operation has been selected using the parameterizing telegram. It was not possible to synchronize to the clock cycle specified by the master. - the master doesn't send a clock synchronous global control telegram although the clock synchronous operation was selected when configuring the bus. - the master is using another clock synchronous DP clock cycle than was transferred to the slave in the parameterizing telegram. - at least one drive object (that is not controlled from PROFIBUS) has a pulse enable.
<b>Remedy:</b>	- check the master application and bus configuration. - check the consistency between the clock cycle input when configuring the slave and clock cycle setting at the master. - ensure that the pulses of drive objects, not controlled from PROFIBUS, are not enabled. Only enable the pulses after synchronizing the PROFIBUS drives.
<b>A01941</b>	<b>PROFIBUS: Clock cycle signal missing when the bus is being established</b>
<b>Reaction:</b>	NONE
<b>Acknowledge:</b>	NONE
<b>Cause:</b>	PROFIBUS is in the data exchange state and clock synchronous operation has been selected using the parameterizing telegram. The global control telegram for synchronization is not being received.
<b>Remedy:</b>	Check the master application and bus configuration.

<b>A01943</b>	<b>PROFIBUS: Clock cycle signal error when the bus is being established</b>
<b>Reaction:</b>	NONE
<b>Acknowledge:</b>	NONE
<b>Cause:</b>	PROFIBUS is in the data exchange state and clock synchronous operation has been selected using the parameterizing telegram. The global control telegram for synchronization is being irregularly received. - the master is sending an irregular global control telegram. - the master is using another clock synchronous DP clock cycle than was transferred to the slave in the parameterizing telegram.
<b>Remedy:</b>	- check the master application and bus configuration. - check the consistency between the clock cycle input when configuring the slave and clock cycle setting at the master.
<b>A01944</b>	<b>PROFIBUS: Sign-of-life synchronism not reached</b>
<b>Reaction:</b>	NONE
<b>Acknowledge:</b>	NONE
<b>Cause:</b>	PROFIBUS is in the data exchange state and clock synchronous operation has been selected using the parameterizing telegram. Synchronization with the master sign-of-life (STW2.12 ... STW2.15) could not be completed because the sign-of-life is changing differently than configured in the Tmapc time grid.
<b>Remedy:</b>	- ensure that the master correctly increments the sign-of-life in the master application clock cycle. - check the interconnection of the master sign-of-life (p2045).
<b>A01945</b>	<b>PROFIBUS: Connection to the Publisher faulted</b>
<b>Reaction:</b>	NONE
<b>Acknowledge:</b>	NONE
<b>Cause:</b>	For PROFIBUS peer-to-peer data transfer, the connection to at least one Publisher is faulted. Alarm value (r2124, interpret binary): Bit 0 = 1: Publisher with address in r2077[0], connection faulted. ... Bit 15 = 1: Publisher with address in r2077[15], connection faulted.
<b>Remedy:</b>	- check the PROFIBUS cables. - carry-out a first commissioning of the Publisher that has the faulted connection. See also: r2077 (PROFIBUS diagnostics peer-to-peer data transfer addresses)
<b>F01946 (A)</b>	<b>PROFIBUS: Connection to the Publisher interrupted</b>
<b>Reaction:</b>	A_INFEED: OFF1 (NONE, OFF2) SERVO: OFF1 (NONE, OFF2, OFF3) VECTOR: OFF1 (NONE, OFF2, OFF3)
<b>Acknowledge:</b>	IMMEDIATELY (POWER ON)
<b>Cause:</b>	At this drive object, the connection to at least one Publisher for PROFIBUS peer-to-peer data transfer in cyclic operation was interrupted. Alarm value (r2124, interpret binary): Bit 0 = 1: Publisher with address in r2077[0], connection interrupted. ... Bit 15 = 1: Publisher with address in r2077[15], connection interrupted.
<b>Remedy:</b>	- check the PROFIBUS cables. - check the state of the Publisher that has the interrupted connection. See also: r2077 (PROFIBUS diagnostics peer-to-peer data transfer addresses)
<b>Reaction upon A:</b>	NONE
<b>Acknowledge upon A:</b>	NONE

<b>F01950 (N, A)</b>	<b>PROFIBUS: Clock synchronous operation, synchronization unsuccessful</b>
<b>Reaction:</b>	OFF1 (NONE)
<b>Acknowledge:</b>	IMMEDIATELY (POWER ON)
<b>Cause:</b>	Synchronization of the internal clock cycle to the global control telegram has failed. The internal clock cycle exhibits an unexpected shift.
<b>Remedy:</b>	Siemens-internal
Reaction upon N:	NONE
Acknowledge upon N:	NONE
Reaction upon A:	NONE
Acknowledge upon A:	NONE
<b>F01951</b>	<b>CU DRIVE-CLiQ: Synchronization application clock cycle missing</b>
<b>Reaction:</b>	OFF2 (NONE)
<b>Acknowledge:</b>	IMMEDIATELY (POWER ON)
<b>Cause:</b>	If DRIVE-CLiQ components with different application clock cycle are operated at a DRIVE-CLiQ port, then this requires synchronization with the Control Unit. This synchronization routine was not successful. Fault value (r0949, decimal): Only for internal Siemens troubleshooting.
<b>Remedy:</b>	- carry-out a POWER ON (power off/on) for all components. - upgrade the Motor Module software. - upgrade the Control Unit software.
<b>F01952</b>	<b>CU DRIVE-CLiQ: Synchronization of component not supported</b>
<b>Reaction:</b>	OFF2 (NONE)
<b>Acknowledge:</b>	IMMEDIATELY (POWER ON)
<b>Cause:</b>	The existing system configuration requires at the connected DRIVE-CLiQ components support the synchronization between the basic clock cycle, DRIVE-CLiQ clock cycle and the application clock cycle. However, not all DRIVE-CLiQ components have this functionality. Fault value (r0949, decimal): Component number of the first faulted DRIVE-CLiQ component.
<b>Remedy:</b>	Upgrade the firmware of the component specified in the fault value. Note: If required, also upgrade additional components in the DRIVE-CLiQ line.
<b>A01953</b>	<b>CU DRIVE-CLiQ: Synchronization not completed</b>
<b>Reaction:</b>	NONE
<b>Acknowledge:</b>	NONE
<b>Cause:</b>	After the drive system is powered-up, the synchronization between the basic clock cycle, DRIVE-CLiQ clock cycle and application clock cycle was started but was not completed within the selected time (tolerance). Alarm value (r2124, decimal): Only for internal Siemens troubleshooting.
<b>Remedy:</b>	Carry-out a POWER ON (power off/on) for all components.
<b>F01954</b>	<b>CU DRIVE-CLiQ: Synchronization unsuccessful</b>
<b>Reaction:</b>	OFF2
<b>Acknowledge:</b>	IMMEDIATELY (POWER ON)
<b>Cause:</b>	After the drive system is powered-up, the synchronization between the basic clock cycle, DRIVE-CLiQ clock cycle and application clock cycle was started and was not able to be successfully completed. Fault value (r0949, decimal): Only for internal Siemens troubleshooting.

**Remedy:**

1. Ensure perfect functioning of the DRIVE-CLiQ.
2. Initiate a new synchronization, e.g. by:
  - remove the PROFIBUS master and re-insert again.
  - restart the PROFIBUS master.
  - power-down the Control Unit and power-up again.
  - press the Control Unit reset button.
  - reset the parameter and download the saved parameters (p0009 = 30, p0976 = 2).

---

**A01955 CU DRIVE-CLiQ: Synchronization DO not completed**

**Reaction:** NONE  
**Acknowledge:** NONE  
**Cause:** After the drive system is powered-up, the synchronization between the basic clock cycle, DRIVE-CLiQ clock cycle and application clock cycle was started but was not completed within the selected time (tolerance).  
 Alarm value (r2124, decimal):  
 Only for internal Siemens troubleshooting.  
**Remedy:** Carry-out a POWER ON (power off/on) for all components of the DO.

---

**A02000 Function generator: Start not possible**

**Reaction:** NONE  
**Acknowledge:** NONE  
**Cause:** The function generator has already been started.  
**Remedy:** Stop the function generator and restart again if necessary.  
 See also: p4800 (Function generator control)

---

**A02005 Function generator: Drive does not exist**

**Reaction:** NONE  
**Acknowledge:** NONE  
**Cause:** The drive object specified for connection does not exist.  
 See also: p4815 (Function generator drive number)  
**Remedy:** Use the existing drive object with the corresponding number.  
 See also: p4815 (Function generator drive number)

---

**A02006 Function generator: No drive specified for connection**

**Reaction:** NONE  
**Acknowledge:** NONE  
**Cause:** No drive specified for connection in p4815.  
 See also: p4815 (Function generator drive number)  
**Remedy:** At least one drive to be connected must be specified in p4815.  
 See also: p4815 (Function generator drive number)

---

**A02007 Function generator: Drive not SERVO**

**Reaction:** NONE  
**Acknowledge:** NONE  
**Cause:** The drive object specified for connection is not a SERVO.  
 See also: p4815 (Function generator drive number)  
**Remedy:** Use a SERVO drive object with the corresponding number.

---

**A02008 Function generator: Drive specified a multiple number of times**

**Reaction:** NONE  
**Acknowledge:** NONE  
**Cause:** The drive object specified for connection is already specified.  
 Alarm value (r2124, decimal):  
 Drive object number of the drive object that is specified a multiple number of times.  
**Remedy:** Specify a different drive object.

---

<b>A02010</b>	<b>Function generator: Speed setpoint from the drive is not zero</b>
<b>Reaction:</b>	NONE
<b>Acknowledge:</b>	NONE
<b>Cause:</b>	The speed setpoint of a drive - selected to be connected to - is greater than the value for the standstill detection set using p1226. Alarm value (r2124, decimal): Number of the drive object involved.
<b>Remedy:</b>	For all of the drives specified for connection, set the speed setpoints to 0.

---

<b>A02011</b>	<b>Function generator: The actual drive speed is not zero</b>
<b>Reaction:</b>	NONE
<b>Acknowledge:</b>	NONE
<b>Cause:</b>	The speed actual value of a drive - selected to be connected to - is greater than the value for the standstill detection set using p1226. Alarm value (r2124, decimal): Number of the drive object involved.
<b>Remedy:</b>	Set the relevant drives to zero speed before starting the function generator.

---

<b>A02015</b>	<b>Function generator: Drive enable signals missing</b>
<b>Reaction:</b>	NONE
<b>Acknowledge:</b>	NONE
<b>Cause:</b>	The master control and/or enable signals are missing to connect to the specified drive. Alarm value (r2124, decimal): Number of the drive object involved. See also: p4815 (Function generator drive number)
<b>Remedy:</b>	Fetch the master control to the specified drive object and set all enable signals.

---

<b>A02020</b>	<b>Function generator: Parameter cannot be changed</b>
<b>Reaction:</b>	NONE
<b>Acknowledge:</b>	NONE
<b>Cause:</b>	This parameter setting cannot be changed when the function generator is active (p4800 = 1). See also: p4810 (Function generator mode), p4812 (Function generator physical address), p4813 (Function generator physical address reference value), p4815 (Function generator drive number), p4820 (Function generator signal shape), p4821 (Function generator period), p4822 (Function generator pulse width), p4823 (Function generator bandwidth), p4824 (Function generator amplitude), p4825 (Function generator 2nd amplitude), p4826 (Function generator offset), p4827 (Function generator ramp-up time to offset), p4828 (Function generator lower limit), p4829 (Function generator upper limit)
<b>Remedy:</b>	- stop before parameterizing the function generator (p4800 = 0). - if required, start the function generator (p4800 = 1). See also: p4800 (Function generator control)

---

<b>A02025</b>	<b>Function generator: Period too short</b>
<b>Reaction:</b>	NONE
<b>Acknowledge:</b>	NONE
<b>Cause:</b>	The value for the period is too short. See also: p4821 (Function generator period)
<b>Remedy:</b>	Check and adapt the value for the period. See also: p4821 (Function generator period)

---

<b>A02026</b>	<b>Function generator: Pulse width too wide</b>
<b>Reaction:</b>	NONE
<b>Acknowledge:</b>	NONE
<b>Cause:</b>	The selected pulse width is too high. The pulse width must be less than the period duration. See also: p4822 (Function generator pulse width)
<b>Remedy:</b>	Reduce pulse width. See also: p4821 (Function generator period), p4822 (Function generator pulse width)

<b>A02030</b>	<b>Function generator: Physical address equals zero</b>
<b>Reaction:</b>	NONE
<b>Acknowledge:</b>	NONE
<b>Cause:</b>	The specified physical address is zero. See also: p4812 (Function generator physical address)
<b>Remedy:</b>	Set a physical address with a value other than zero. See also: p4812 (Function generator physical address)
<b>A02040</b>	<b>Function generator: Impermissible value for offset</b>
<b>Reaction:</b>	NONE
<b>Acknowledge:</b>	NONE
<b>Cause:</b>	The value for the offset is higher than the value for the upper limit or lower than the value for the lower limit. See also: p4826 (Function generator offset)
<b>Remedy:</b>	Adjust the offset value accordingly. See also: p4826 (Function generator offset), p4828 (Function generator lower limit), p4829 (Function generator upper limit)
<b>A02041</b>	<b>Function generator: Impermissible value for bandwidth</b>
<b>Reaction:</b>	NONE
<b>Acknowledge:</b>	NONE
<b>Cause:</b>	The bandwidth, referred to the time slice clock cycle of the function generator has either been set too low or too high. Depending on the time slice clock cycle, the bandwidth is defined as follows: Bandwidth_max = 1 / (2 * time slice clock cycle) Bandwidth_min = Bandwidth_max / 100000 Example: Assumption: p4830 = 125 µs --> Bandwidth_max = 1 / (2 * 125 µs) = 4000 Hz --> Bandwidth_min = 4000 Hz / 100000 = 0.04 Hz Note: p4823: Function generator bandwidth p4830: Function generator time slice clock cycle See also: p4823 (Function generator bandwidth), p4830 (Function generator time slice cycle)
<b>Remedy:</b>	Check the value for the bandwidth and appropriately adapt.
<b>A02047</b>	<b>Function generator: Time slice clock cycle invalid</b>
<b>Reaction:</b>	NONE
<b>Acknowledge:</b>	NONE
<b>Cause:</b>	The time slice cycle selected does not match any of the existing time slices. See also: p4830 (Function generator time slice cycle)
<b>Remedy:</b>	Input an existing time slice cycle. The existing time slices can be read out via p7901. See also: r7901 (Time slice cycle times)
<b>A02050</b>	<b>Trace: Start not possible</b>
<b>Reaction:</b>	NONE
<b>Acknowledge:</b>	NONE
<b>Cause:</b>	The trace has already been started. See also: p4700 (Trace control)
<b>Remedy:</b>	Stop the trace and, if necessary, start again.
<b>A02055</b>	<b>Trace: Recording time too short</b>
<b>Reaction:</b>	NONE
<b>Acknowledge:</b>	NONE
<b>Cause:</b>	The trace duration is too short. The minimum is twice the value of the trace clock cycle. See also: p4721 (Trace recording time)
<b>Remedy:</b>	Check the selected recording time and, if necessary, adjust.



---

<b>A02056</b>	<b>Trace: Recording cycle too short</b>
<b>Reaction:</b>	NONE
<b>Acknowledge:</b>	NONE
<b>Cause:</b>	The selected recording cycle is shorter than the selected basis clock cycle 0 (p0110[0]). See also: p4720 (Trace recording cycle)
<b>Remedy:</b>	Increase the value for the trace cycle.

---

<b>A02057</b>	<b>Trace: Time slice clock cycle invalid</b>
<b>Reaction:</b>	NONE
<b>Acknowledge:</b>	NONE
<b>Cause:</b>	The time slice cycle selected does not match any of the existing time slices. See also: p4723 (Time slice cycle for trace)
<b>Remedy:</b>	Input an existing time slice cycle. The existing time slices can be read out via p7901. See also: r7901 (Time slice cycle times)

---

<b>A02060</b>	<b>Trace: Signal to be traced missing</b>
<b>Reaction:</b>	NONE
<b>Acknowledge:</b>	NONE
<b>Cause:</b>	- a signal to be traced was not specified. - the specified signals are not valid. See also: p4730 (Trace record signal 0), p4731 (Trace record signal 1), p4732 (Trace record signal 2), p4733 (Trace record signal 3)
<b>Remedy:</b>	- specify the signal to be traced. - check whether the relevant signal can be traced.

---

<b>A02061</b>	<b>Trace: Invalid signal</b>
<b>Reaction:</b>	NONE
<b>Acknowledge:</b>	NONE
<b>Cause:</b>	- the specified signal does not exist. - the specified signal can no longer be traced (recorded). See also: p4730 (Trace record signal 0), p4731 (Trace record signal 1), p4732 (Trace record signal 2), p4733 (Trace record signal 3)
<b>Remedy:</b>	- specify the signal to be traced. - check whether the relevant signal can be traced.

---

<b>A02062</b>	<b>Trace: Invalid trigger signal</b>
<b>Reaction:</b>	NONE
<b>Acknowledge:</b>	NONE
<b>Cause:</b>	- a trigger signal was not specified. - the specified signal does not exist. - the specified signal is not a fixed-point signal. - the specified signal cannot be used as trigger signal for the trace. See also: p4711 (Trace trigger signal)
<b>Remedy:</b>	Specify a valid trigger signal.

---

<b>A02063</b>	<b>Trace: Invalid data type</b>
<b>Reaction:</b>	NONE
<b>Acknowledge:</b>	NONE
<b>Cause:</b>	The specified data type to select a signal using a physical address is invalid. See also: p4711 (Trace trigger signal), p4730 (Trace record signal 0), p4731 (Trace record signal 1), p4732 (Trace record signal 2), p4733 (Trace record signal 3)
<b>Remedy:</b>	Use a valid data type.

<b>A02070</b>	<b>Trace: Parameter cannot be changed</b>
<b>Reaction:</b>	NONE
<b>Acknowledge:</b>	NONE
<b>Cause:</b>	The trace parameter settings cannot be changed when the trace is active. See also: p4700 (Trace control), p4710 (Trace trigger condition), p4711 (Trace trigger signal), p4712 (Trace trigger threshold), p4713 (Trace tolerance band trigger threshold), p4714 (Trace tolerance band trigger threshold), p4715 (Trace bit mask trigger, bit mask), p4716 (Trace, bit mask trigger, trigger condition), p4720 (Trace recording cycle), p4721 (Trace recording time), p4722 (Trace trigger delay), p4730 (Trace record signal 0), p4731 (Trace record signal 1), p4732 (Trace record signal 2), p4733 (Trace record signal 3), p4780 (Trace physical address signal 0), p4781 (Trace physical address signal 1), p4782 (Trace physical address signal 2), p4783 (Trace physical address signal 3), p4789 (Trace physical address trigger signal), p4795 (Trace memory bank changeover)
<b>Remedy:</b>	- stop the trace before parameterization. - if required, start the trace.
<b>A02075</b>	<b>Trace: Pretrigger time too long</b>
<b>Reaction:</b>	NONE
<b>Acknowledge:</b>	NONE
<b>Cause:</b>	The selected pretrigger time must be shorter than the recording time. See also: p4721 (Trace recording time), p4722 (Trace trigger delay)
<b>Remedy:</b>	Check the pretrigger time setting and change if necessary.
<b>A02099</b>	<b>Trace: Insufficient Control Unit memory</b>
<b>Reaction:</b>	NONE
<b>Acknowledge:</b>	NONE
<b>Cause:</b>	The memory space still available on the Control Unit is no longer sufficient for the trace function.
<b>Remedy:</b>	Reduce the memory required, e.g. as follows: - reduce the trace (record) time. - increase the trace clock cycle. - reduce the number of signals to be traced (recorded). See also: r4708 (Trace memory space required), r4799 (Trace memory location free)
<b>A02100</b>	<b>CU: Computation deadtime current controller too short</b>
<b>Reaction:</b>	NONE
<b>Acknowledge:</b>	NONE
<b>Cause:</b>	The value in p0118 produces a dead time of one clock cycle because it lies before the setpoint becomes available. A possible cause could be, for example, that the system characteristics no longer match those parameterized after a component has been replaced. Alarm value (r2134, floating point): The minimum value for p0118 where a deadtime no longer occurs.
<b>Remedy:</b>	- set p0118 to a value greater than or equal to the alarm value. - set p0117 to an automatic setting. - check the firmware releases of the components involved. See also: p0117 (Current controller computation deadtime mode), p0118 (Current controller computation deadtime)
<b>A02150</b>	<b>OA application cannot be loaded</b>
<b>Reaction:</b>	NONE
<b>Acknowledge:</b>	NONE
<b>Cause:</b>	The system was not able to load an OA application. Alarm value (r2124, interpret hexadecimal): Only for internal Siemens troubleshooting.
<b>Remedy:</b>	- carry-out a POWER ON (power off/on) for all components. - upgrade the firmware release. - contact the Hotline. See also: r4950 (OA application count), r4955 (OA application identifier), p4956 (OA application activation), r4957 (OA application version)

---

<b>F02151 (A)</b>	<b>OA application, internal software error</b>
<b>Reaction:</b>	A_INFEED: OFF2 (NONE, OFF1) SERVO: OFF2 (NONE, OFF1, OFF3) VECTOR: OFF2 (NONE, OFF1, OFF3)
<b>Acknowledge:</b>	IMMEDIATELY (POWER ON)
<b>Cause:</b>	An internal software error has occurred within an OA application. Fault value (r0949, interpret hexadecimal): Only for internal Siemens troubleshooting.
<b>Remedy:</b>	- carry-out a POWER ON (power off/on) for all components. - upgrade the firmware release. - contact the Hotline. - replace the Control Unit. See also: r4950 (OA application count), r4955 (OA application identifier), p4956 (OA application activation), r4957 (OA application version)
Reaction upon A:	NONE
Acknowledge upon A:	NONE

---

<b>F02152 (A)</b>	<b>OA application, insufficient memory</b>
<b>Reaction:</b>	OFF1
<b>Acknowledge:</b>	IMMEDIATELY (POWER ON)
<b>Cause:</b>	Two many functions, data sets or drives configured on this Control Unit. Fault value (r0949, decimal): Only for internal Siemens troubleshooting.
<b>Remedy:</b>	- change the configuration on this Control Unit. - use an additional Control Unit. See also: r4950 (OA application count), r4955 (OA application identifier), p4956 (OA application activation), r4957 (OA application version)
Reaction upon A:	NONE
Acknowledge upon A:	NONE

---

<b>F03500 (A)</b>	<b>TM: Initialization</b>
<b>Reaction:</b>	OFF1 (OFF2)
<b>Acknowledge:</b>	IMMEDIATELY (POWER ON)
<b>Cause:</b>	When initializing the Terminal Modules, the terminals of the Control Unit or the Terminal Board 30, an internal software error has occurred. Fault value (r0949, decimal): The thousands location = 1 ... 3: The component number (p0151) of the module involved is specified at the ones, tens and hundreds position.
<b>Remedy:</b>	- power-down the power supply for the Control Unit and power-up again. - check the DRIVE-CLiQ connection. - if required, replace the Terminal Module. The Terminal Module should be directly connected to a DRIVE-CLiQ socket of the Control Unit. If the fault occurs again, replace the Terminal Module.
Reaction upon A:	NONE
Acknowledge upon A:	NONE

---

<b>A03501</b>	<b>TM: Sampling time change</b>
<b>Reaction:</b>	NONE
<b>Acknowledge:</b>	NONE
<b>Cause:</b>	The sampling times of the inputs/outputs were changed. This change only becomes valid after the next boot.
<b>Remedy:</b>	Carry-out a POWER ON.

**F03505 (N, A)    TM: Analog input, wire breakage**

**Reaction:** OFF1 (OFF2)

**Acknowledge:** IMMEDIATELY (POWER ON)

**Cause:** The input current of the TM analog input has exceeded the threshold value parameterized in p4061[x]. This fault can only occur, if p4056[x] = 3 (4 ... 20 mA with monitoring) is set.  
 Index x = 0: Analog input 0 (X522.1 to .3)  
 Index x = 1: Analog input 1 (X522.4 to .5)  
 Fault value (r0949, decimal):  
 The component number (p0151) of the module involved is specified at the ones, tens and hundreds position. The thousands position specifies the analog input involved: 0: Analog input 0 (AI 0), 1: Analog input 1 (AI 1)

**Remedy:** Check the connection to the signal source for interruptions.  
 Check the magnitude of the impressed current - it is possible that the impressed signal is too low.  
 Please note that the input has a load resistor of 250 Ohm.  
 The input current measured by the TM can be read-out of r4052[x].

Reaction upon N: NONE  
 Acknowledge upon N: NONE  
 Reaction upon A: NONE  
 Acknowledge upon A: NONE

**A03550    TM: Speed setpoint filter natural frequency > Shannon frequency**

**Reaction:** NONE

**Acknowledge:** NONE

**Cause:** The natural filter frequency of the speed setpoint filter (p1417) is greater than the Shannon frequency. The Shannon frequency is calculated according to the following formula:  $0.5 / p0115[0]$   
 See also: p1417 (Speed setpoint filter 1 denominator natural frequency)

**Remedy:** Reduce the natural frequency of the speed setpoint filter (PT2 low pass) (p1417).

**F03590 (N, A)    TM: Module not ready**

**Reaction:** A\_INFEED: OFF2 (NONE)  
 SERVO: NONE (DCBRAKE, ENCODER, OFF1, OFF2, OFF3, STOP1, STOP2)  
 VECTOR: OFF2 (DCBRAKE, ENCODER, NONE, OFF1, OFF3, STOP1, STOP2)

**Acknowledge:** IMMEDIATELY (POWER ON)

**Cause:** The Terminal Module involved does not send a ready signal and no valid cyclic data.  
 Fault value (r0949, decimal):  
 Drive object number.

**Remedy:** - check the 24 V power supply.  
 - check the DRIVE-CLiQ connection.

Reaction upon N: NONE  
 Acknowledge upon N: NONE  
 Reaction upon A: NONE  
 Acknowledge upon A: NONE

**A05000 (N)    Power unit: Heatsink overtemperature**

**Reaction:** NONE

**Acknowledge:** NONE

**Cause:** The alarm threshold for overtemperature at the inverter heatsink has been reached. The response is set using p0290.  
 If the temperature of the heatsink increases by an additional 5 K, then fault F30004 is initiated.

**Remedy:** Check the following:  
 - is the ambient temperature within the defined limit values?  
 - have the load conditions and the load duty cycle been appropriately dimensioned?  
 - has the cooling failed?

Reaction upon N: NONE  
Acknowledge upon N: NONE

---

**A05001 (N) Power unit: Chip overtemperature**

**Reaction:** NONE

**Acknowledge:** NONE

**Cause:** Alarm threshold for overtemperature of the power semiconductor in the AC converter has been reached. The response is set using p0290.  
If the chip temperature increases by an additional 15 K, then fault F30025 is initiated.

**Remedy:** Check the following:  
- is the ambient temperature within the defined limit values?  
- have the load conditions and the load duty cycle been appropriately dimensioned?  
- has the cooling failed?  
- pulse frequency too high?  
See also: r0037 (Power unit temperatures), p0290 (Power unit overload response)

Reaction upon N: NONE  
Acknowledge upon N: NONE

---

**A05002 (N) Power unit: Air intake overtemperature**

**Reaction:** NONE

**Acknowledge:** NONE

**Cause:** The alarm threshold for the air intake overtemperature has been reached. For air-cooled power units, the threshold is 42 degrees Celcius (hysteresis 2 K). The response is set using p0290.  
If the air intake temperature increases by an additional 13 K, then fault F30035 is output.

**Remedy:** Check the following:  
- is the ambient temperature within the defined limit values?  
- has the fan failed? Check the direction of rotation.

Reaction upon N: NONE  
Acknowledge upon N: NONE

---

**A05003 (N) Power unit: Electronics board overtemperature**

**Reaction:** NONE

**Acknowledge:** NONE

**Cause:** The alarm threshold for the overtemperature of the electronics module has been reached. The response is set using p0290.  
If the temperature of the electronics module increases by an additional 5 K, then fault F30036 is initiated.

**Remedy:** Check the following:  
- is the ambient temperature within the defined limit values?  
- has the fan failed? Check the direction of rotation.

Reaction upon N: NONE  
Acknowledge upon N: NONE

---

**A05004 (N) Power unit: Rectifier overtemperature**

**Reaction:** NONE

**Acknowledge:** NONE

**Cause:** The alarm threshold for the overtemperature of the rectifier has been reached. The response is set using p0290.  
If the temperature of the rectifier increases by an additional 5 K, then fault F30037 is initiated.

**Remedy:** Check the following:  
- is the ambient temperature within the defined limit values?  
- have the load conditions and the load duty cycle been appropriately dimensioned?  
- has the fan failed? Check the direction of rotation.  
- has a phase of the line supply failed?  
- is an arm of the supply (incoming) rectifier defective?

Reaction upon N: NONE  
 Acknowledge upon N: NONE

---

**A05005 Cooling system: Cooling medium flow rate too low**

**Reaction:** NONE  
**Acknowledge:** NONE  
**Cause:** Cooling system: Alarm - flow rate has fallen below the alarm value  
**Remedy:**

---

**F05050 Parallel circuit: Pulse enable in spite of pulse inhibit**

**Reaction:** A\_INFEED: OFF2 (NONE, OFF1)  
 VECTOR: OFF2 (NONE, OFF1, OFF3, STOP1, STOP2)  
**Acknowledge:** IMMEDIATELY  
**Cause:** A power unit signals that the pulses are enabled although the pulses are inhibited.  
 Fault value (r0949, decimal):  
 Number of the power unit involved.  
**Remedy:** The power unit is defective and must be replaced.

---

**F05051 Parallel circuit: Power unit pulse enable missing**

**Reaction:** A\_INFEED: OFF2 (NONE, OFF1)  
 VECTOR: OFF2 (NONE, OFF1, OFF3, STOP1, STOP2)  
**Acknowledge:** IMMEDIATELY  
**Cause:** For one or several power units, the pulses were not able to be enabled.  
 Fault value (r0949, decimal):  
 Number of the power unit involved.  
**Remedy:** - acknowledge power unit faults that are still present.  
 - inhibit the pulses of the power unit involved (p7001).

---

**A05052 (F) Parallel circuit: Impermissible current dissymmetry**

**Reaction:** NONE  
**Acknowledge:** NONE  
**Cause:** The deviation of the individual currents of the power units exceeds the alarm threshold specified in p7010.  
 Alarm value (r2124, decimal):  
 1: Phase U.  
 2: Phase V.  
 3: Phase W.  
**Remedy:** - inhibit the pulses of the faulted power unit (p7001).  
 - check the connecting cables. Loose contacts can cause current spikes.  
 - the motor reactors are non-symmetrical or faulty and must be replaced.  
 - the CTs must be calibrated or replaced.  
 Reaction upon F: A\_INFEED: NONE (OFF1, OFF2)  
 VECTOR: NONE (OFF1, OFF2, OFF3, STOP1, STOP2)  
 Acknowledge upon F: IMMEDIATELY

---

**A05053 (F) Parallel circuit: Inadmissible DC link voltage dissymmetry**

**Reaction:** NONE  
**Acknowledge:** NONE  
**Cause:** The deviation of the DC link voltage measured values exceeds the alarm threshold specified in p7011.  
**Remedy:** - inhibit the pulses of the faulted power unit (p7001).  
 - check the DC link connecting cables.  
 - the DC link voltage measurement is incorrect and must be calibrated or renewed.  
 Reaction upon F: A\_INFEED: NONE (OFF1, OFF2)  
 VECTOR: NONE (OFF1, OFF2, OFF3, STOP1, STOP2)  
 Acknowledge upon F: IMMEDIATELY

<b>A05054</b>	<b>Parallel circuit: Power unit de-activated</b>
<b>Reaction:</b>	NONE
<b>Acknowledge:</b>	NONE
<b>Cause:</b>	For the drive object involved, fewer power unit components connected in parallel are active than exist in the target topology. Operation is only possible at reduced power (power de-rating).
<b>Remedy:</b>	Re-activate the de-activated power unit components. See also: p0125 (Activate/de-activate power unit components), p0895 (Activate/de-activate power unit components), p0897 (Parking axis selection)
<b>F05055</b>	<b>Power circuit: Power units with different code numbers</b>
<b>Reaction:</b>	NONE
<b>Acknowledge:</b>	IMMEDIATELY
<b>Cause:</b>	The code numbers of the power units do not match. Fault value (r0949, decimal): Parameter in which the first different power unit code number was detected.
<b>Remedy:</b>	For parallel circuit configurations, only power units with identical power unit data may be used.
<b>F05056</b>	<b>Parallel circuit: Power unit EPROM versions differ</b>
<b>Reaction:</b>	NONE
<b>Acknowledge:</b>	IMMEDIATELY
<b>Cause:</b>	The EEPROM versions of the power units do not match. Fault value (r0949, decimal): Parameter in which the first different version number was detected.
<b>Remedy:</b>	For parallel circuit configurations, only power units with identical EEPROM versions may be used.
<b>F05057</b>	<b>Parallel circuit: Power unit firmware versions differ</b>
<b>Reaction:</b>	NONE
<b>Acknowledge:</b>	IMMEDIATELY
<b>Cause:</b>	The firmware versions of the power units connected in parallel do not match. Fault value (r0949, decimal): Parameter in which the first different version number was detected.
<b>Remedy:</b>	For parallel circuit configurations, only power units with identical firmware versions may be used.
<b>F05058</b>	<b>Parallel circuit: VSM EEPROM versions differ</b>
<b>Reaction:</b>	NONE
<b>Acknowledge:</b>	IMMEDIATELY
<b>Cause:</b>	The EEPROM versions of the Voltage Sensing Modules (VSM) do not match. Fault value (r0949, decimal): Parameter in which the first different version number was detected.
<b>Remedy:</b>	For parallel circuit configurations, only Voltage Sensing Modules (VSM) with identical EEPROM versions may be used.
<b>F05059</b>	<b>Parallel circuit: VSM firmware versions differ</b>
<b>Reaction:</b>	NONE
<b>Acknowledge:</b>	IMMEDIATELY
<b>Cause:</b>	The firmware versions of the Voltage Sensing Modules (VSM) do not match. Fault value (r0949, decimal): Parameter in which the first different version number was detected.
<b>Remedy:</b>	For parallel circuit configurations, only Voltage Sensing Modules (VSM) with identical firmware versions may be used.
<b>F05060</b>	<b>Parallel circuit: Power unit firmware version does not match</b>
<b>Reaction:</b>	NONE
<b>Acknowledge:</b>	IMMEDIATELY
<b>Cause:</b>	Firmware from version V02.30.01.00 is required when connecting the power units in parallel.
<b>Remedy:</b>	Update the firmware of the power units (at least V02.30.01.00).

<b>F05061</b>	<b>Infeed, number of VSM</b>
<b>Reaction:</b>	NONE
<b>Acknowledge:</b>	IMMEDIATELY
<b>Cause:</b>	The number of active Voltage Sensing Modules (VSM) for the drive object infeed with chassis power units is not correct. For A_Infeed, each active power unit must be assigned an active VSM also for a parallel circuit configuration. For S_Infeed, the active drive object, must be assigned at least one active VSM. Fault value (r0949, decimal): Number of VSMs that are currently assigned to the drive object.
<b>Remedy:</b>	Adapts the number of active Voltage Sensing Modules (VSM).
<b>F06000</b>	<b>Infeed: Precharging monitoring time expired</b>
<b>Reaction:</b>	OFF2 (OFF1)
<b>Acknowledge:</b>	IMMEDIATELY
<b>Cause:</b>	After the line contactor closes the power unit does not signal the READY state within the monitoring time (p0857). The end of the DC link pre-charging was not detected due to one of the following reasons: - there is not line supply voltage. - the line contactor is not closed. - the line supply voltage is too low. - the power unit has detected an internal fault. - there is a DC link short-circuit. - the DC link has a ground fault. - the pre-charging resistors are overheated as there were too many pre-charging operations per time unit. - the pre-charging resistors are overheated as the DC link capacitance is too high (max. 20 mF). - line supply voltage incorrectly set. See also: p0857 (Power unit monitoring time)
<b>Remedy:</b>	- check the line supply voltage - check or energize the line contactor. - check and if required increase the monitoring time p0857. - if relevant, carefully note additional power unit fault messages. - check the DC link regarding short-circuit or ground fault. - wait until the pre-charging resistors have cooled down. - reduce the DC link capacitance by removing the power units or supplementary modules. - check the line supply voltage setting (p0210).
<b>F06010</b>	<b>Infeed: Power unit EP 24 V missing in operation</b>
<b>Reaction:</b>	OFF2 (OFF1)
<b>Acknowledge:</b>	IMMEDIATELY (POWER ON)
<b>Cause:</b>	In operation, withdraw the pulse enable at terminal EP at the Line Module (X21.3, X21.4).
<b>Remedy:</b>	- do not open the line breaker in operation - only when the pulses are inhibited. - check the wiring of the DP input (X21.3, X21.4) at the Line Module to exclude any poor contacts.
<b>F06050</b>	<b>Infeed: Smart Mode not supported</b>
<b>Reaction:</b>	OFF2
<b>Acknowledge:</b>	IMMEDIATELY (POWER ON)
<b>Cause:</b>	The power unit does not support the Smart Mode.
<b>Remedy:</b>	- set the sampling time p0115[0] >= 250 µs by setting the pre-setting (default) of the sampling time (p0112) to the factory setting. - de-activate the Smart Mode with p3400 and supply voltage p0210 <= 415 V. - upgrade the power unit software and/or hardware for the smart mode (r0192). See also: r0192 (Power unit firmware properties)



---

<b>F06100</b>	<b>Infeed: Shutdown due to line supply undervoltage condition</b>
<b>Reaction:</b>	OFF2 (OFF1)
<b>Acknowledge:</b>	IMMEDIATELY (POWER ON)
<b>Cause:</b>	The filtered (steady-state) value of the line supply voltage is less than the fault threshold (p0283). Alarm condition: $V_{rms} < p0283 * p0210$ . Fault value (r0949, floating point): Actual steady-state line supply voltage. See also: p0283 (Line supply undervoltage, shutdown (trip) threshold)
<b>Remedy:</b>	- check the line supply. - check the line supply voltage (p0210). - check the fault threshold (p0283).

---

<b>A06105 (F)</b>	<b>Infeed: Line supply undervoltage</b>
<b>Reaction:</b>	NONE
<b>Acknowledge:</b>	NONE
<b>Cause:</b>	The filtered (steady-state) value of line supply voltage is lower than the alarm threshold (p0282). Alarm condition: $V_{rms} < p0282 * p0210$ . Alarm value (r2124, floating point): Actual steady-state line supply voltage. See also: p0282 (Line supply undervoltage, alarm threshold)
<b>Remedy:</b>	- check the line supply. - check the line supply voltage (p0210). - check the alarm threshold (p0282).
Reaction upon F:	NONE (OFF1, OFF2)
Acknowledge upon F:	IMMEDIATELY (POWER ON)

---

<b>F06200</b>	<b>Infeed: Failure of one or several line phases</b>
<b>Reaction:</b>	OFF2 (OFF1)
<b>Acknowledge:</b>	IMMEDIATELY (POWER ON)
<b>Cause:</b>	Failure of one or several line phases. The fault can be output in two operating states: 1. During the power-on phase of the infeed unit. The measured line supply angle deviates from the regular characteristic for a 3-phase system - the PLL cannot be synchronized. The fault occurs immediately after power-up if, when operating with a VSM, the phase assignment L1, L2, L3 at the VSM differs from the phase assignment at the power unit. 2. While the infeed is operational. After a voltage dip has been detected (A06205) in one or several line phases a fault occurred within 100 ms (also refer to other relevant messages). Probable causes of the fault: - voltage dip on the line side or phase phase failure lasting longer than 10 ms. - overload condition on the load side with peak current. - commutating reactor missing.
<b>Remedy:</b>	- check the line supply and fuses. - check the connection and size (rating) of the line commutating reactor. - check and correct the phase assignment at the VSM and at the power unit. - check the load. See also: p3463 (Infeed, line angle change, phase failure detection)

<b>A06205 (F)</b>	<b>Infeed: Voltage dip in at least one line supply phase</b>
<b>Reaction:</b>	NONE
<b>Acknowledge:</b>	NONE
<b>Cause:</b>	Voltage dip or overvoltage in one or several line supply phases has been detected in operation. The pulses are then cancelled for 10 ms. The operating signal of the infeed unit in r0863.0 remains and the pulse inhibit due to the phase failure is displayed in r3405.2. Alarm value (r2124, decimal): Internal fault type of the line angle characteristic.
<b>Remedy:</b>	- check the line supply and fuses. - check the line supply quality and system fault level. - check the load. See also: r3405 (Status word infeed), p3463 (Infeed, line angle change, phase failure detection)
Reaction upon F:	NONE (OFF1, OFF2)
Acknowledge upon F:	IMMEDIATELY (POWER ON)
<b>F06210</b>	<b>Infeed: Summed current too high</b>
<b>Reaction:</b>	OFF2 (OFF1)
<b>Acknowledge:</b>	IMMEDIATELY (POWER ON)
<b>Cause:</b>	Smoothed sum of the phase currents ( $i_1 + i_2 + i_3$ ) greater than 4 % of the maximum power unit current (r0209). Possible causes: - the DC link has a ground fault that results in a high summed current (r0069.6). The DC component in the line currents can damage/destroy the power unit, commutating reactor or line filter! - the zero point calibration of the current measurement was not carried-out (p3491, A06602). - defective current measurement in the power unit. Fault value (r0949, floating point): Smoothed sum of the phase currents.
<b>Remedy:</b>	- check the DC link for a low-ohmic or high-ohmic ground fault and if one is present, remove. - increase the monitoring time of the current-offset measurement (p3491). - if required, replace the power unit.
<b>A06215 (F)</b>	<b>Infeed: Summed current high</b>
<b>Reaction:</b>	NONE
<b>Acknowledge:</b>	NONE
<b>Cause:</b>	Smoothed sum of the phase currents ( $i_1 + i_2 + i_3$ ) greater than 3 % of the maximum power unit current (r0209). Possible causes: - the DC link has a ground fault that results in a high summed current (r0069.6). The DC component in the line currents can damage/destroy the power unit, commutating reactor or line filter! - the zero point calibration of the current measurement was not carried-out (p3491, A06602). - defective current measurement in the power unit. Alarm value (r2124, floating point): Smoothed sum of the phase currents.
<b>Remedy:</b>	- check the DC link for a low-ohmic or high-ohmic ground fault and if one is present, remove. - increase the monitoring time of the current-offset measurement (p3491). - if required, replace the power unit.
Reaction upon F:	NONE (OFF1, OFF2)
Acknowledge upon F:	IMMEDIATELY (POWER ON)

<b>A06250 (F)</b>	<b>Infeed: Defective capacitor(s) in at least one phase of line filter</b>
<b>Reaction:</b>	NONE
<b>Acknowledge:</b>	NONE
<b>Cause:</b>	<p>A change in the line filter capacitance was detected in at least line phase.                      The voltages and phase currents of the line filter, measured using a Voltage Sensing Module (VSM), indicated a deviation of the filter capacitances from the value parameterized in p0221.                      A change or a defect of the line filter capacitors results in a shift of the resonant frequencies and can result in severe damage to the drive system.                      Alarm value (r2124, floating point):                      The calculated actual capacitance in <math>\mu\text{F}</math> (rounded-off to an integer number).                      The 1st decimal point specifies the number of the phase (1, 2, 3) where the capacitance deviates from the specified value.</p>
<b>Remedy:</b>	<ul style="list-style-type: none"> <li>- check the parameterized value of the filter capacitance (p0221).</li> <li>- check the correct wiring of the Voltage Sensing Module (VSM):                      Differential voltages u12 and u23 must be present at the 100 V/690 V inputs of the VSM; the phase currents of the line filter must be connected to the 10 V inputs through a current - voltage converter.</li> <li>- check the alarm limits for the permissible filter capacitance deviation (p3676).</li> <li>- check the normalization of the line supply voltage measurement using the VSM (p3660).</li> <li>- check the normalization of the filter current measurement using the VSM (p3670).</li> <li>- check the line filter capacitors and if required, replace the line filter.</li> </ul> <p>See also: p0221 (Infeed filter capacitance), p3660 (VSM input line supply voltage, voltage scaler), p3670 (VSM 10 V input CT gain), p3676 (VSM line filter capacitance alarm threshold)</p>
Reaction upon F:	NONE (OFF1, OFF2)
Acknowledge upon F:	IMMEDIATELY (POWER ON)
<b>F06300</b>	<b>Infeed: Line voltage too high at power on</b>
<b>Reaction:</b>	OFF2 (NONE, OFF1)
<b>Acknowledge:</b>	IMMEDIATELY (POWER ON)
<b>Cause:</b>	<p>The RMS line supply voltage <math>V_{\text{rms}}</math> was so high when powering-up that controlled operation is not possible without exceeding the permissible maximum voltage in the DC link (p0280).                      Fault condition: <math>V_{\text{rms}} * 1.5 &gt; p0280</math>.                      Fault value (r0949, floating point):                      Lowest possible controlled DC link voltage for the line supply voltage presently connected.                      See also: p0280 (DC link voltage maximum steady-state)</p>
<b>Remedy:</b>	<ul style="list-style-type: none"> <li>- check the line supply voltage</li> <li>- check the maximum DC link voltage and if required, increase (p0280).</li> <li>- check the line supply voltage and compare with the actual line supply voltage (p0210).</li> <li>- check whether the power unit is dimensioned for the line supply voltage actually being used.</li> </ul> <p>See also: p0210 (Drive unit line supply voltage), p0280 (DC link voltage maximum steady-state)</p>
<b>A06301 (F)</b>	<b>Infeed: Line supply overvoltage</b>
<b>Reaction:</b>	NONE
<b>Acknowledge:</b>	NONE
<b>Cause:</b>	<p>The filtered (steady-state) value of the rms line supply voltage <math>V_{\text{rms}}</math> is higher than the alarm threshold (p0281).                      Alarm condition: <math>V_{\text{rms}} &gt; p0281 * p0210</math>.                      Alarm value (r2124, floating point):                      Actual steady-state line supply voltage.                      See also: p0281 (Line supply overvoltage, warning threshold)</p>
<b>Remedy:</b>	<ul style="list-style-type: none"> <li>- check the line supply.</li> <li>- check the line supply voltage (p0210).</li> <li>- check the alarm threshold (p0281).</li> </ul> <p>See also: p0210 (Drive unit line supply voltage), p0281 (Line supply overvoltage, warning threshold)</p>
Reaction upon F:	NONE (OFF1, OFF2)
Acknowledge upon F:	IMMEDIATELY (POWER ON)

---

<b>F06310 (A)</b>	<b>Infeed: Supply voltage (p0210) incorrectly parameterized</b>
<b>Reaction:</b>	NONE (OFF1, OFF2)
<b>Acknowledge:</b>	IMMEDIATELY (POWER ON)
<b>Cause:</b>	After pre-charging was completed, the line supply voltage $V_{rms}$ was calculated using the measured DC link voltage. This voltage $V_{rms}$ is not within the tolerance range of the supply voltage. The following applies for the tolerance range: $85\% * p0210 < V_{rms} < 110\% * p0210$ . Alarm value (r2124, floating point): Line supply voltage $V_{rms}$ present. See also: p0210 (Drive unit line supply voltage)
<b>Remedy:</b>	- check the parameterized supply voltage and if required change (p0210). - check the line supply voltage. See also: p0210 (Drive unit line supply voltage)
Reaction upon A:	NONE
Acknowledge upon A:	NONE

---

<b>A06350 (F)</b>	<b>Infeed: Measured line frequency too high</b>
<b>Reaction:</b>	NONE
<b>Acknowledge:</b>	NONE
<b>Cause:</b>	The actual line frequency $f_{line}$ is higher than the parameterized alarm threshold ( $f_{line} > p0211 * p0284$ ). The alarm can be output in two operating states: 1. During the power-on phase of the infeed unit. Consequence: Synchronization of the infeed to the line supply is interrupted and is restarted. 2. While the infeed is operational. Consequence: The infeed remains in the operating (run) state and alarm A6350 is output. This signifies a critical operational fault. Alarm value (r2124, floating point): Actual line frequency determined. See also: p0284 (Line supply frequency exceeded, alarm threshold)
<b>Remedy:</b>	- check the parameterized line frequency and if required change (p0211). - check the alarm threshold (p0284). - check the line supply. - check the line supply quality. See also: p0211 (Rated line freq), p0284 (Line supply frequency exceeded, alarm threshold)
Reaction upon F:	NONE (OFF1, OFF2)
Acknowledge upon F:	IMMEDIATELY (POWER ON)

---

<b>A06351 (F)</b>	<b>Infeed: Measured line frequency too low</b>
<b>Reaction:</b>	NONE
<b>Acknowledge:</b>	NONE
<b>Cause:</b>	The actual line frequency $f_{line}$ is lower than the parameterized alarm threshold ( $f_{line} < p0211 * p0285$ ). The alarm can be output in two operating states: 1. During the power-on phase of the infeed unit. Consequence: Synchronization of the infeed to the line supply is interrupted and is restarted. 2. While the infeed is operational. Consequence: The infeed remains in the operating (run) state and alarm A06351 is output. This signifies a critical operational fault. Alarm value (r2124, floating point): Actual line frequency determined. See also: p0285 (Line supply frequency fallen below, alarm threshold)
<b>Remedy:</b>	- check the parameterized line frequency and if required change (p0211). - check the alarm threshold (p0285). - check the line supply. - check the line supply quality. See also: p0211 (Rated line freq), p0285 (Line supply frequency fallen below, alarm threshold)

Reaction upon F: NONE (OFF1, OFF2)  
 Acknowledge upon F: IMMEDIATELY (POWER ON)

**A06400 Infeed: Line supply data identification selected/active**

**Reaction:** NONE  
**Acknowledge:** NONE  
**Cause:** The line supply data identification is selected and active.  
 The line inductance and the DC link capacitance are measured at the next pulse enable.  
 SM150: The Active Line Module is synchronized the next time that the pulses are enabled and the identification mode, selected in p3410 is carried-out or the identification mode, displayed in r6442 is presently active. The INFEEED\_READY signal is not generated.  
 See also: p3410 (Infeed identification method)  
**Remedy:** No remedial action required.

**F06500 Infeed: Line synchronization not possible**

**Reaction:** OFF2 (OFF1)  
**Acknowledge:** IMMEDIATELY (POWER ON)  
**Cause:** The line synchronization is not possible within the monitoring time.  
 The infeed was re-synchronized to the line supply because it was interrupted due to a line frequency that was determined to be either too low or too high.  
 After 20 attempts, synchronization - and therefore also the power-on operation - were interrupted.  
**Remedy:**  
 - check the parameterized line frequency and if required change (p0211).  
 - check the fault thresholds (p0284, p0285).  
 - check the line supply.  
 - check the line supply quality.  
 See also: p0211 (Rated line freq), p0284 (Line supply frequency exceeded, alarm threshold), p0285 (Line supply frequency fallen below, alarm threshold)

**A06601 (F) Infeed: Current offset measurement interrupted**

**Reaction:** NONE  
**Acknowledge:** NONE  
**Cause:** Defective current measurement or a DC current is present during the offset measurement.  
 Alarm value (r2124, decimal):  
 1: Excessively high phase current has occurred during the current-offset calibration.  
 2: The measured current - offset is greater than the 3% of the maximum permissible converter current (e.g. due to a ground fault in the DC link).  
**Remedy:**  
 Re alarm value = 1:  
 - possible counter-measure if there is no line contactor: Power-up an adequately long time before OFF1 = 1.  
 Re alarm value = 2:  
 - defective current measurement or a DC current is present during the offset measurement.  
 - check the DC link for a ground fault.  
 Reaction upon F: NONE (OFF1, OFF2)  
 Acknowledge upon F: IMMEDIATELY (POWER ON)

**A06602 (F) Infeed: Current offset measurement not possible**

**Reaction:** NONE  
**Acknowledge:** NONE  
**Cause:** After an OFF1 = 1 no valid current offset measurement was able to be made within the monitoring time (p3491) before closing the line contactor. The current offset is set to 0.  
 See also: p3491 (Infeed I-offset measurement monitoring time)  
**Remedy:**  
 - check the DC link for a ground fault. A ground fault can destroy parts and components!  
 - Check the monitoring time setting and if required increase (p3491). At least 100 ms is required for a valid measurement (p3491 > 100 ms).  
 Notice:  
 If there is no valid measurement, then under certain circumstances the quality of the DC link control will be reduced.  
 See also: p3491 (Infeed I-offset measurement monitoring time)

Reaction upon F: NONE (OFF1, OFF2)  
 Acknowledge upon F: IMMEDIATELY (POWER ON)

---

**F06700 (A) Infeed: Switch line contactor for load condition**  
**Reaction:** NONE (OFF2)  
**Acknowledge:** IMMEDIATELY  
**Cause:** For an on command, the infeed line contactor should be switched under load.  
**Remedy:** - do not load the DC link if the infeed has not issued an operating signal (r0863.0 = 1).  
 - after the infeed has been powered-down, all power units connected to the DC link should be powered-down. To realize this, the operating signal of the infeed (r0863.0) must be suitable interconnected.

Reaction upon A: NONE  
 Acknowledge upon A: NONE

---

**A06800 (F) Infeed: Maximum steady-state DC link voltage reached**  
**Reaction:** NONE  
**Acknowledge:** NONE  
**Cause:** The DC link voltage setpoint has reached the maximum steady-state voltage parameterized in p0280. The DC link voltage is increased by the modulation depth reserve controller for the following reasons:  
 - modulation depth reserve is too low (p3480).  
 - line supply voltage is too high.  
 - supply voltage (p0210) parameterized to be too low.  
 - excessively high setpoint for the reactive line current.  
**Remedy:** - check the line supply voltage setting (p0210).  
 - check the line supply for an overvoltage condition.  
 - reduce the modulation depth reserve (p3480).  
 - reduce the reactive current setpoint.  
 See also: p0210 (Drive unit line supply voltage), p0280 (DC link voltage maximum steady-state), p3480 (Infeed modulation depth limit)

Reaction upon F: NONE (OFF1, OFF2)  
 Acknowledge upon F: IMMEDIATELY (POWER ON)

---

**A06900 (F) Braking Module: Fault (1 -> 0)**  
**Reaction:** NONE  
**Acknowledge:** NONE  
**Cause:** The Braking Module signals "Fault (1 -> 0)" via terminal X21.4. This signal is interconnected via binector input BI: p3866[0...7]. See also: p3866 (Braking Module fault)  
**Remedy:** - reduce the number of braking operations.  
 - check binector input BI: p3866[0...7] and the wiring to terminal X21.4 of the particular braking module.

Reaction upon F: NONE (OFF2)  
 Acknowledge upon F: IMMEDIATELY

---

**A06901 Braking Module: Pre-alarm I\*t shutdown**  
**Reaction:** NONE  
**Acknowledge:** NONE  
**Cause:** The Braking Module signals "Pre-alarm I\*t shutdown" via terminal X21.3. This signal is interconnected via binector input p3865[0...7]. The pre-alarm I\*t shutdown is only possible for Braking Modules, "booksize" type, "chassis" devices do not support this function.  
**Remedy:** - reduce the number of braking operations.  
 - check binector input BI: p3865[0...7] and the wiring to terminal X21.3 of the particular Braking Module.

<b>F07011</b>	<p><b>Drive: Motor overtemperature</b></p> <p><b>Reaction:</b> OFF2 (NONE, OFF1, OFF3, STOP1, STOP2)</p> <p><b>Acknowledge:</b> IMMEDIATELY</p> <p><b>Cause:</b> KTY: The motor temperature has exceeded the fault threshold (p0605) or the timer stage (p0606) after the alarm threshold was exceeded (p0604) has expired. VECTOR: The response parameterized in p0610 becomes active. PTC: The response threshold of 1650 Ohm was exceeded and the timer stage (p0606) has expired. VECTOR: The response parameterized in p0610 becomes active. Possible causes: - motor is overloaded. - motor ambient temperature too high. - wire breakage or sensor not connected Fault value (r0949, decimal), if SME is selected in p0601 (p0601=10): The number specifies the sensor channel that resulted in the alarm being output. See also: p0604 (Motor overtemperature alarm threshold), p0605 (Motor overtemperature fault threshold), p0606 (Motor overtemperature timer), p0610 (Response to motor overtemperature condition)</p> <p><b>Remedy:</b> - reduce the motor load. - check the ambient temperature. - check the wiring and sensor connector. See also: p0604 (Motor overtemperature alarm threshold), p0605 (Motor overtemperature fault threshold), p0606 (Motor overtemperature timer)</p>
<b>A07015</b>	<p><b>Drive: Motor temperature sensor alarm</b></p> <p><b>Reaction:</b> NONE</p> <p><b>Acknowledge:</b> NONE</p> <p><b>Cause:</b> An error was detected when evaluating the temperature sensor set in p0600 and p0601. With the fault, the time in p0607 is started. If the fault is still present after this time has expired, then fault F07016 is output; however, at the earliest, 1 s after alarm A07015. Possible causes: - wire breakage or sensor not connected (KTY: R &gt; 1630 Ohm). - measured resistance too low (PTC: R &lt; 20 Ohm, KTY: R &lt; 50 Ohm). Alarm value (r2124, decimal), if SME is selected in p0601 (p0601=10): The number specifies the sensor channel that resulted in the alarm being output.</p> <p><b>Remedy:</b> - check that the sensor is connected correctly. - check the parameterization (p0600, p0601). See also: r0035 (Motor temperature), p0600 (Motor temperature sensor for monitoring), p0601 (Motor temperature sensor type), p0607 (Temperature sensor fault timer)</p>
<b>F07016</b>	<p><b>Drive: Motor temperature sensor fault</b></p> <p><b>Reaction:</b> OFF1 (NONE, OFF2, OFF3, STOP1, STOP2)</p> <p><b>Acknowledge:</b> IMMEDIATELY</p> <p><b>Cause:</b> An error was detected when evaluating the temperature sensor set in p0600 and p0601. Possible causes: - wire breakage or sensor not connected (KTY: R &gt; 1630 Ohm). - measured resistance too low (PTC: R &lt; 20 Ohm, KTY: R &lt; 50 Ohm). Note: If alarm A07015 is present, the time in p0607 is started. If the fault is still present after this time has expired, then fault F07016 is output; however, at the earliest, 1 s after alarm A07015. Fault value (r0949, decimal), if SME is selected in p0601 (p0601=10): The number specifies the sensor channel that resulted in the alarm being output. See also: p0607 (Temperature sensor fault timer)</p> <p><b>Remedy:</b> - check that the sensor is connected correctly. - check the parameterization (p0600, p0601). - induction motors: De-activate temperature sensor fault (p0607 = 0). See also: r0035 (Motor temperature), p0600 (Motor temperature sensor for monitoring), p0601 (Motor temperature sensor type), p0607 (Temperature sensor fault timer)</p>

<b>F07080</b>	<b>Drive: Incorrect control parameter</b>
<b>Reaction:</b>	NONE
<b>Acknowledge:</b>	IMMEDIATELY (POWER ON)
<b>Cause:</b>	<p>The closed-loop control parameters have been parameterized incorrectly (e.g. p0356 = L_spread = 0).                      Fault value (r0949, decimal):                      The fault value includes the parameter number involved.                      The following parameter numbers only occur as fault values for vector drives:                      p0310, for synchronous motors: p0341, p0344, p0350, p0357                      The following parameter numbers do not occur as fault values for synchronous motors:                      p0354, p0358, p0360                      See also: p0310 (Rated motor frequency), p0311 (Rated motor speed), p0341 (Motor moment of inertia), p0344 (Motor weight), p0350 (Motor stator resistance, cold), p0354 (Motor rotor resistance cold / damping resistance d axis), p0356 (Motor stator leakage inductance), p0357 (Motor stator inductance, d axis), p0358 (Motor rotor leakage inductance / damping inductance, d axis), p0360 (Motor magnetizing inductance/magn. inductance, d axis saturated), p0400 (Enc type selection), p0640 (Current limit), p1082 (Maximum speed), p1300 (Open-loop/closed-loop control operating mode)</p>
<b>Remedy:</b>	<p>Modify the parameter indicated in the fault value (r0949) (e.g. p0640 = current limit &gt; 0).                      See also: p0311 (Rated motor speed), p0341 (Motor moment of inertia), p0344 (Motor weight), p0350 (Motor stator resistance, cold), p0354 (Motor rotor resistance cold / damping resistance d axis), p0356 (Motor stator leakage inductance), p0358 (Motor rotor leakage inductance / damping inductance, d axis), p0360 (Motor magnetizing inductance/magn. inductance, d axis saturated), p0400 (Enc type selection), p0640 (Current limit), p1082 (Maximum speed)</p>
<b>F07082</b>	<b>Macro: Execution not possible</b>
<b>Reaction:</b>	NONE
<b>Acknowledge:</b>	IMMEDIATELY
<b>Cause:</b>	<p>The macro cannot be executed.                      Fault value (r0949, interpret hexadecimal):                      The fault code is in byte 1, possibly supplementary information is in byte 2 and the high word contains the parameter number involved if this is available.                      Fault codes:                      Fault for the trigger parameter itself:                      -20: Called file is not valid for parameter 15.                      -21: Called file is not valid for parameter 700.                      -22: Called file is not valid for parameter 1000.                      -23: Called file is not valid for parameter 1500.                      -24: Data type of a TAG is incorrect (e.g.: Index, number or bit is not U16).                      Faults for the parameters to be set:                      -25: Error level has an undefined value.                      -26: Mode has an undefined value.                      -27: A value was entered as string in the tag value that is not "DEFAULT".                      -31: Entered drive object type unknown.                      -32: A device was not able to be found for the determined drive object number.                      -34: A trigger parameter was recursively called.                      -35: It is not permissible to write to the parameter via macro.                      -36: Check, writing to a parameter unsuccessful, parameter can only be read, not available, incorrect data type, value range or assignment incorrect.                      -37: Source parameter for a BICO interconnection was not able to be determined.                      -38: An index was set for a non-indexed parameter.                      -39: No index was set for an indexed parameter.                      -41: A bit operation is only permissible for parameters with the parameter format DISPLAY_BIN.                      -42: A value not equal to 0 or 1 was set for a BitOperation.                      -43: Reading the parameter to be changed by the BitOperation was unsuccessful.                      -51: Factory setting for DEVICE may only be executed on the DEVICE.                      -61: The setting of a value was unsuccessful.</p>
<b>Remedy:</b>	<p>- check the parameter involved.                      - check the macro file and BICO interconnection.                      See also: p0015 (Macro drive unit), p0700 (Macro Binector Input (BI)), p1000 (Macro Connector Inputs (CI) for speed setpoints), p1500 (Macro Connector Inputs (CI) for torque setpoints)</p>



<b>F07083</b>	<b>Macro: ACX file not found</b>
<b>Reaction:</b>	NONE
<b>Acknowledge:</b>	IMMEDIATELY
<b>Cause:</b>	The ACX file (macro) to be executed was not able to be found in the appropriate directory. Fault value (r0949, decimal): Parameter number with which the execution was started. See also: p0015 (Macro drive unit), p0700 (Macro Binector Input (BI)), p1000 (Macro Connector Inputs (CI) for speed setpoints), p1500 (Macro Connector Inputs (CI) for torque setpoints)
<b>Remedy:</b>	- check whether the file is saved in the appropriate directory on the CompactFlash card. Example: If p0015 is set to 1501, then the selected ACX file must be located in the following directory: ... /PMACROS/DEVICE/P15/PM001501.ACX
<b>F07084</b>	<b>Macro: Condition for WaitUntil not fulfilled</b>
<b>Reaction:</b>	NONE
<b>Acknowledge:</b>	IMMEDIATELY
<b>Cause:</b>	The wait condition set in the macro was not fulfilled in a certain number of attempts. Fault value (r0949, decimal): Parameter number for which the condition was set.
<b>Remedy:</b>	Check and correct the conditions for the WaitUntil loop.
<b>F07085</b>	<b>Drive: Open-loop/closed-loop control parameters changed</b>
<b>Reaction:</b>	NONE
<b>Acknowledge:</b>	IMMEDIATELY (POWER ON)
<b>Cause:</b>	Parameters of the open-loop/closed-loop control had to be changed as they exceeded dynamic limits as a result of other parameters. Fault value (r0949, decimal): The fault value includes the modified parameter number. See also: p0640 (Current limit), p1082 (Maximum speed), p1300 (Open-loop/closed-loop control operating mode), p1800 (Pulse frequency)
<b>Remedy:</b>	It is not necessary to change the parameters as they have already been correctly limited.
<b>F07086</b>	<b>Units changeover: Calculating parameter values after an int. system ref. value change unsuccessful</b>
<b>Reaction:</b>	NONE
<b>Acknowledge:</b>	IMMEDIATELY
<b>Cause:</b>	A reference parameter was changed in the system. This resulted in the fact that for the parameter involved, the selected value was not able to be written in the per unit notation (cause, e.g. the minimum or maximum limit was violated). The value of this parameter was set to default. Fault value (r0949, parameter): Parameter involved that was not able to be recalculated. See also: p0304 (Rated motor voltage), p0305 (Rated motor current), p0310 (Rated motor frequency), p0596 (Reference quantity, technological units), p2000 (Reference frequency), p2001 (Reference voltage), p2002 (Reference current), p2003 (Reference torque), r2004 (Reference power)
<b>Remedy:</b>	Check, and if required, correct the adapted parameter value. See also: p0304 (Rated motor voltage), p0305 (Rated motor current), p0310 (Rated motor frequency), p0596 (Reference quantity, technological units), p2000 (Reference frequency), p2001 (Reference voltage), p2002 (Reference current), p2003 (Reference torque), r2004 (Reference power)
<b>F07090</b>	<b>Drive: Upper torque limit less than the lower torque limit</b>
<b>Reaction:</b>	OFF2 (NONE, OFF1, OFF3)
<b>Acknowledge:</b>	IMMEDIATELY
<b>Cause:</b>	The upper torque limit is lower than the lower torque limit.
<b>Remedy:</b>	P1 must be >= P2 if parameter P1 is connected to p1522 and parameter P2 to p1523.

<b>F07100</b>	<b>Drive: Sampling times cannot be reset</b>
<b>Reaction:</b>	NONE
<b>Acknowledge:</b>	IMMEDIATELY
<b>Cause:</b>	When resetting drive parameter (p0976) sampling times cannot be reset using p0111, p0112, p0115. Fault value (r0949, decimal): Parameter whose setting prevents the sampling times being reset. See also: r0110 (DRIVE-CLiQ basis sampling times)
<b>Remedy:</b>	- continue to work with the set sampling times. - before resetting the drive parameters, set the basic clock cycle p0110[0] to the original value. See also: r0110 (DRIVE-CLiQ basis sampling times)
<b>F07110</b>	<b>Drive: Sampling times and basic clock cycle do not match</b>
<b>Reaction:</b>	NONE
<b>Acknowledge:</b>	IMMEDIATELY
<b>Cause:</b>	The parameterized sampling times do not match the basic clock cycle. Fault value (r0949, decimal): The fault value specifies the parameter involved. See also: r0110 (DRIVE-CLiQ basis sampling times), r0111 (DRIVE-CLiQ basis sampling time selection), p0115 (Sampling time for supplementary functions)
<b>Remedy:</b>	Enter the current controller sampling times so that they are identical to the basic clock cycle, e.g. by selecting p0112. Note which basic clock cycle is selected in p0111. The sampling times in p0115 can only be changed manually in the sampling times preset "Expert" (p0112). See also: r0110 (DRIVE-CLiQ basis sampling times), r0111 (DRIVE-CLiQ basis sampling time selection), p0112 (Sampling times pre-setting p0115), p0115 (Sampling time for supplementary functions)
<b>A07200</b>	<b>Drive: Master control ON/OFF1 command present</b>
<b>Reaction:</b>	NONE
<b>Acknowledge:</b>	NONE
<b>Cause:</b>	The ON/OFF1 command is not 0, either via binector input p0840 (current CDS) or in control word p3982 bit 0.
<b>Remedy:</b>	The signal at binector input p0840 (actual CDS) as well as p3982 bit 0 must be 0.
<b>F07210</b>	<b>Master control PC/AOP inhibited</b>
<b>Reaction:</b>	NONE
<b>Acknowledge:</b>	IMMEDIATELY
<b>Cause:</b>	The transfer of master control is disabled via binector input p3985.
<b>Remedy:</b>	Change the signal via binector input p3985.
<b>F07220 (N, A)</b>	<b>Drive: Control by PLC missing</b>
<b>Reaction:</b>	A_INFEED: OFF1 (NONE, OFF2) SERVO: OFF1 (NONE, OFF2, OFF3, STOP1, STOP2) VECTOR: OFF1 (NONE, OFF2, OFF3, STOP1, STOP2)
<b>Acknowledge:</b>	IMMEDIATELY
<b>Cause:</b>	The "control by PLC" signal was missing in operation. - interconnection of the binector input for "control by PLC" is incorrect (p0854). - the higher-level control has withdrawn the "control by PLC" signal. - data transfer via the fieldbus (master - drive) was interrupted.
<b>Remedy:</b>	- check the interconnection of the binector input for "control by PLC" (p0854). - check the "control by PLC" signal and, if required, switch-in. - check the data transfer via the fieldbus (master - drive). Note: If the drive should continue to operate after withdrawing "control by PLC" then fault response must be parameterized to NONE or the message type should be parameterized as alarm.
<b>Reaction upon N:</b>	NONE
<b>Acknowledge upon N:</b>	NONE
<b>Reaction upon A:</b>	NONE
<b>Acknowledge upon A:</b>	NONE

---

**F07300 (A) Drive: Line contactor feedback signal missing**

**Reaction:** OFF2 (NONE)  
**Acknowledge:** IMMEDIATELY  
**Cause:** - the line contactor was not able to be closed within the time in p0861.  
 - the line contactor was not able to be opened within the time in p0861.  
 - the line contactor has dropped-out in operation.  
 - the line contactor has closed although the drive converter is powered-down.  
**Remedy:** - check the setting of p0860.  
 - check the feedback circuit from the line contactor.  
 - increase the monitoring time in p0861.  
 See also: p0860 (Line cont. fdbk sig), p0861 (Line contactor monitoring time)  
 Reaction upon A: NONE  
 Acknowledge upon A: NONE

---

**F07311 Bypass motor switch**

**Reaction:** OFF2  
**Acknowledge:** IMMEDIATELY  
**Cause:** Fault value: Bit field BYPASS\_CONTACTOR\_ERROR\_STATE  
 Bit 1  
 BYPASS\_CONTACTOR\_ERR\_FBK\_ON\_MISSING  
 Switch "closed" feedback signal missing  
 Bit 2  
 BYPASS\_CONTACTOR\_ERR\_FBK\_OFF\_MISSING  
 Switch "opened" feedback signal missing  
 Bit 3  
 BYPASS\_CONTACTOR\_ERR\_TOO\_SLOW  
 Switch feedback signal too slow:  
 After switching, the system waits for the positive feedback signal. If the feedback signal is received later than the specified time, then a fault trip (shutdown) is issued.  
 Bit 6  
 BYPASS\_CONTACTOR\_ERR\_BYPASS\_INCONSISTENCY  
 Drive switch feedback signal is not consistent with the bypass state:  
 When powering-up or for STAGING, the drive switch is closed.  
 See also: p1260 (Bypass configuration), r1261 (Bypass control/status word), p1266 (Bypass, control command), p1267 (Bypass changeover source configuration), p1269 (Bypass switch feedback signal), p1274 (Bypass switch monitoring time)  
**Remedy:** - check the transfer of the feedback signal.  
 - check the switch

---

**F07312 Bypass line supply switch**

**Reaction:** OFF2  
**Acknowledge:** IMMEDIATELY  
**Cause:** Fault value: Bit field BYPASS\_CONTACTOR\_ERROR\_STATE  
 Bit 1  
 BYPASS\_CONTACTOR\_ERR\_FBK\_ON\_MISSING  
 Switch "closed" feedback signal missing  
 Bit 2  
 BYPASS\_CONTACTOR\_ERR\_FBK\_OFF\_MISSING  
 Switch "opened" feedback signal missing  
 Bit 3  
 BYPASS\_CONTACTOR\_ERR\_TOO\_SLOW  
 Switch feedback signal too slow:  
 After switching, the system waits for the positive feedback signal. If the feedback signal is received later than the specified time, then a fault trip (shutdown) is issued.  
 Bit 6  
 BYPASS\_CONTACTOR\_ERR\_BYPASS\_INCONSISTENCY

Line switch feedback signal is not consistent with the bypass state:

When powering-up or for STAGING, the line switch is closed without this having been requested from the bypass. See also: p1260 (Bypass configuration), r1261 (Bypass control/status word), p1266 (Bypass, control command), p1267 (Bypass changeover source configuration), p1269 (Bypass switch feedback signal), p1274 (Bypass switch monitoring time)

**Remedy:**

- check the transfer of the feedback signal.
- check the switch

**F07320 Drive: Automatic restart interrupted**

**Reaction:** OFF2

**Acknowledge:** IMMEDIATELY

**Cause:**

- The specified number of restart attempts (p1211) has been completely used up because within the monitoring time p1213 the alarms were not able to be acknowledged. The number of restart attempts (p1211) is decremented at each new start attempt.
- there is no active ON command.
- the monitoring time for the power unit (p0857) has expired.
- when exiting commissioning or at the end of the motor identification routine or the speed controller optimization, the drive unit is not automatically powered-up again.

Fault value (r0949, interpret hexadecimal):  
Only for internal Siemens troubleshooting.

**Remedy:**

- increase the number of restart attempts (p1211). The actual number of starting attempts is displayed in r1214.
- increase the delay time in p1212 and/or the monitoring time in p1213.
- issue an ON command (p0840).
- either increase or disable the monitoring time of the power unit (p0857).

**A07321 Drive: Automatic restart active**

**Reaction:** NONE

**Acknowledge:** NONE

**Cause:** The automatic restart (AR) is active. When the line supply returns and/or the causes of the existing faults are removed the drive is automatically restarted. The pulses are enabled and the motor starts to rotate.

**Remedy:**

- the automatic restart (AR) should, if required, be inhibited (p1210 = 0).
- an automatic restart can be directly interrupted by withdrawing the power-on command (BI: p0840).

**A07329 (N) Drive: kT estimator active without functioning compensation of the voltage emulation error**

**Reaction:** NONE

**Acknowledge:** NONE

**Cause:** The kT estimator is active (p1780.3 = 1) without a functioning compensation of the voltage emulation error in the drive converter. This means that the accuracy is severely restricted.  
Fault value (r0949, decimal):

- 1: The drive converter voltage emulation error, final value is 0 (p1952).
- 2: The drive converter voltage emulation error, current offset is 0 (p1953).
- 3: The compensation of the voltage emulation error is disabled (p1780.8 = 0).

**Remedy:** Re fault value 1, 2:

- carry-out an identification of the voltage emulation error in the drive converter (p1909.14 = 1, p1910 = 1).
- set the parameter to compensation the voltage emulation error in the drive converter (p1952, p1953).

Re fault value 3:

- enable the compensation of the voltage emulation error in the drive converter (p1780.8 = 1).

Reaction upon N: NONE

Acknowledge upon N: NONE

**F07330 Flying restart: Measured search current too low**

**Reaction:** OFF2 (NONE, OFF1)

**Acknowledge:** IMMEDIATELY

**Cause:** During a flying restart, it was identified that the search current reached is too low. It is possible that the motor is not connected.

**Remedy:** Check the motor feeder cables.

<b>F07331</b>	<b>FlyRestart: Not supported</b>
<b>Reaction:</b>	OFF2 (NONE, OFF1)
<b>Acknowledge:</b>	IMMEDIATELY
<b>Cause:</b>	It is not possible to power-up with the motor rotating (no flying restart). In the following cases, the "flying restart" function is not supported: Permanent-magnet and separately-excited synchronous motors (PEM, FEM): Operation with U/f characteristic. Permanent-magnet synchronous motor (PEM): Sensorless operation without a Voltage Sensing Module (VSM) being connected.
<b>Remedy:</b>	- de-activate the "flying restart" function (p1200 = 0). - change the open-loop/closed-loop control mode (p1300). - connect a Voltage Sensing Module (VSM) (voltage measurement).
<b>A07350 (F)</b>	<b>Drive: Measuring probe parameterized to a digital output</b>
<b>Reaction:</b>	NONE
<b>Acknowledge:</b>	NONE
<b>Cause:</b>	The measuring probe is connected to a bi-directional digital input/output and the terminal is set as output. Alarm value (r2124, decimal): 9: DI/DO 9 (X122.8) 10: DI/DO 10 (X122.10) 11: DI/DO 11 (X122.11) 13: DI/DO 13 (X132.8) 14: DI/DO 14 (X132.10) 15: DI/DO 15 (X132.11)
<b>Remedy:</b>	- set the terminal as input (p0728). - de-select the measuring probe (p0488, p0489, p0580).
Reaction upon F:	OFF1
Acknowledge upon F:	IMMEDIATELY
<b>A07400 (N)</b>	<b>Drive: DC link voltage maximum controller active</b>
<b>Reaction:</b>	NONE
<b>Acknowledge:</b>	NONE
<b>Cause:</b>	The DC link voltage controller has been activated because the upper switch-in threshold has been exceeded (r1242). The ramp-down times are automatically increased in order to maintain the DC link voltage (r0026) within the permissible limits. There is a system deviation between the setpoint and actual speeds. When the DC link voltage controller is switched-out (disabled), this is the reason that the ramp-function generator output is set to the speed actual value. See also: p1240 (Vdc controller or Vdc monitoring configuration)
<b>Remedy:</b>	If the controller is not to intervene: - increase the ramp-down times. - disable the Vdc max controller If the ramp-down times are not to be changed: - use a chopper or regenerative feedback unit
Reaction upon N:	NONE
Acknowledge upon N:	NONE
<b>A07401 (N)</b>	<b>Drive: DC link voltage maximum controller de-activated</b>
<b>Reaction:</b>	NONE
<b>Acknowledge:</b>	NONE
<b>Cause:</b>	The Vdc_max controller can no longer maintain the DC link voltage (r0026) below the limit value (r1242) and was therefore switched-out (disabled). - the line supply voltage is permanently higher than specified for the power unit. - the motor is permanently in the regenerative mode as a result of a load that is driving the motor.
<b>Remedy:</b>	- check whether the input voltage is within the permissible range. - check whether the load duty cycle and load limits are within the permissible limits.

Reaction upon N: NONE  
 Acknowledge upon N: NONE

---

**A07402 (N) Drive: DC link voltage minimum controller active**  
**Reaction:** NONE  
**Acknowledge:** NONE  
**Cause:** The DC link voltage controller has been activated as the lower switch-in threshold has been fallen below (r1246). The kinetic energy of the motor is used in order to buffer the DC link. This brakes the drive. See also: p1240 (Vdc controller or Vdc monitoring configuration)  
**Remedy:** The alarm disappears when power supply returns.  
 Reaction upon N: NONE  
 Acknowledge upon N: NONE

---

**F07403 Drive: Lower DC link voltage threshold reached**  
**Reaction:** OFF1 (NONE, OFF2, OFF3)  
**Acknowledge:** IMMEDIATELY  
**Cause:** The DC link voltage monitoring is active (p1240 = 2, 3) and the lower DC link voltage threshold (p1248) was reached in the "Operation" state.  
**Remedy:**  
 - check the line supply voltage.  
 - check the infeed module  
 - reduce the lower DC link threshold (p1248).  
 - switch-out (disable) the DC link voltage monitoring (p1240 = 0).

---

**F07404 Drive: Upper DC link voltage threshold reached**  
**Reaction:** OFF2 (NONE, OFF1, OFF3)  
**Acknowledge:** IMMEDIATELY  
**Cause:** The DC link voltage monitoring is active (p1240 = 1, 3) and the upper DC link voltage threshold (p1244) was reached in the "Operation" state.  
**Remedy:**  
 - check the line supply voltage.  
 - check the infeed module or the Braking Module.  
 - increase the upper DC link voltage threshold (p1244).  
 - switch-out (disable) the DC link voltage monitoring (p1240 = 0).

---

**F07405 (N, A) Drive: Kinetic buffering minimum speed not reached**  
**Reaction:** OFF2 (DCBRAKE, OFF1, OFF3, STOP1, STOP2)  
**Acknowledge:** IMMEDIATELY  
**Cause:** During kinetic buffering the speed fell below minimum speed (p1257) and the line supply did not return.  
**Remedy:** Check the speed threshold for the Vdc\_min controller (kinetic buffering) (p1257). See also: p1257 (Vdc\_min controller speed threshold)  
 Reaction upon N: NONE  
 Acknowledge upon N: NONE  
 Reaction upon A: NONE  
 Acknowledge upon A: NONE

---

**F07406 (N, A) Drive: Kinetic buffering maximum time exceeded**  
**Reaction:** OFF3 (DCBRAKE, OFF1, OFF2, STOP1, STOP2)  
**Acknowledge:** IMMEDIATELY  
**Cause:** The maximum buffer time (p1255) has been exceeded but the line supply has not returned.  
**Remedy:** Check the time threshold for Vdc-min controller (kinetic buffering) (p1255). See also: p1255 (Vdc\_min controller time threshold)  
 Reaction upon N: NONE  
 Acknowledge upon N: NONE

Reaction upon A: NONE  
 Acknowledge upon A: NONE

**A07409 Drive: U/f control, current limiting controller active**  
**Reaction:** NONE  
**Acknowledge:** NONE  
**Cause:** The current limiting controller of the U/f control was activated because the current limit was exceeded.  
**Remedy:** The alarm is automatically withdrawn when increasing the current limit (p0640), reducing the load or using a slower up ramp for the setpoint (reference) speed.

**F07410 Drive: Current controller output limited**  
**Reaction:** OFF2 (NONE, OFF1)  
**Acknowledge:** IMMEDIATELY  
**Cause:** The condition " $I_{act} = 0$  and  $U_q\_set\_1$  longer than 16 ms at its limit" is present and can be caused by the following:  
 - motor not connected or motor contactor open.  
 - no DC link voltage present.  
 - Motor Module defective.  
 - the "flying restart" function is not activated.  
**Remedy:**  
 - connect the motor or check the motor contactor.  
 - check the DC link voltage (r0070).  
 - check the Motor Module.  
 - activate the "flying restart" function (p1200).

**F07411 Drive: Flux controller output limited**  
**Reaction:** OFF2 (NONE, OFF1)  
**Acknowledge:** IMMEDIATELY  
**Cause:** The specified flux setpoint cannot be reached although 90% of the maximum current has been specified.  
 - incorrect motor data.  
 - motor data and motor configuration (star/delta) do not match.  
 - the current limit has been set too low for the motor.  
 - induction motor (sensorless, open-loop controlled) in I2t limiting.  
 - the Motor Module is too small.  
**Remedy:**  
 - correct the motor data.  
 - check the motor configuration.  
 - correct the current limits (p0640, p0323).  
 - reduce the induction motor load.  
 - if required, use a larger Motor Module.

**F07412 Drive: Commutation angle incorrect (motor model)**  
**Reaction:** ENCODER (NONE, OFF2)  
**Acknowledge:** IMMEDIATELY  
**Cause:** An incorrect commutation angle was detected, that can result in a positive coupling in the speed controller.  
 Servo:  
 Supplementary value 0: The comparison of the pole position angle from the encoder and the motor model resulted in an excessively high value (> 80 ° electrical).  
 Supplementary value 1: -  
 Vector:  
 Supplementary value 0: The comparison of the pole position angle from the encoder and the motor model resulted in an excessively high value (> 45 ° electrical).  
 Supplementary value 1: The change in the speed signal from the motor encoder has changed by > P0492 within a current controller clock cycle.

Possible causes:

- the motor encoder is incorrectly adjusted with respect to the magnet position.
- the motor encoder is damaged.
- the angular commutation offset is incorrectly set (p0431).
- data to calculate the motor model has been incorrectly set (p0356 (motor-stator leakage inductance) and/or p0350 (motor-stator resistance) and/or p0352 (cable resistance)).
- the changeover speed for the motor model is too low (p1752). The monitoring function only becomes effective above the changeover speed.
- the motor encoder speed signal is faulted.
- the control loop is instable due to incorrect parameterization.

- Remedy:**
- if the encoder mounting was changed - re-adjust the encoder.
  - replace the defective motor encoder.
  - correctly set the angular commutation offset (p0431).
  - correctly set the motor stator leakage inductance, motor-stator resistance and cable resistance (p0356, p0350, p0352).
  - increase the changeover speed for the motor model (p1752).

---

**F07413 Drive: Commutation angle incorrect (pole position identification)**

**Reaction:** ENCODER (NONE, OFF2)

**Acknowledge:** IMMEDIATELY

**Cause:** An incorrect commutation angle was detected, that can result in a positive coupling in the speed controller.

- within the pole position identification routine (p1982 = 2):  
A difference of > 45° electrical to the encoder angle was determined.
- for VECTOR, within the encoder adjustment (p1990 = 2):  
A difference of > 6° electrical to the encoder angle was determined.

- Remedy:**
- correctly set the angular commutation offset (p0431).
  - re-adjust the motor encoder after the encoder has been replaced.
  - replace the defective motor encoder.
  - check the pole position identification routine. If the pole position identification routine is not suitable for this motor type, then disable the plausibility check (p1982 = 0).

---

**F07414 Drive: Encoder serial number changed**

**Reaction:** ENCODER (NONE, OFF2)

**Acknowledge:** IMMEDIATELY

**Cause:** The serial number of the motor encoder of a synchronous motor has changed. The change was only checked for encoders with serial number (e.g. EnDat encoders) and build-in motors (e.g. p300 = 401) or third-party motors (p0300 = 2).

Cause 1:

The motor with integrated and adjusted encoder was replaced.

Cause 2:

The encoder was replaced.

Cause 3:

A third-party, build-in or linear motor was re-commissioned.

Cause 4:

The firmware was updated to a version that checks the encoder serial number.

**Remedy:**

Re causes 1, 4:

Accept the new serial number with p0440 = 1.

Re causes 2, 3:

Carry-out an automatic adjustment using the pole position identification routine. First, accept the serial number with p0440 = 1. Acknowledge the fault. Initiate the pole position identification routine with p1990 = 1. Then check that the pole position identification routine is correctly executed.

SERVO: If a pole position identification technique is selected in p1980, and if p0301 does not contain a motor type with an encoder adjusted in the factory, then p1990 is automatically activated.

or

Set the adjustment using parameter p0431. In this case, the new serial number is automatically accepted.

or

Mechanically adjust the encoder. Accept the new serial number with p0440 = 1.



<b>N07415 (F)</b>	<b>Drive: Angular commutation offset transfer running</b>
<b>Reaction:</b>	OFF2
<b>Acknowledge:</b>	NONE
<b>Cause:</b>	The angular commutation offset was automatically determined using $p1990 = 1$ . This fault causes the pulses to be cancelled - this is necessary to transfer the angular commutation offset to p0431. See also: p1990 (Angular commutation offset, commissioning support)
<b>Remedy:</b>	The fault can be acknowledged without any additional measures.
Reaction upon F:	OFF2
Acknowledge upon F:	IMMEDIATELY
<b>F07420</b>	<b>Drive: Current setpoint filter natural frequency &gt; Shannon frequency</b>
<b>Reaction:</b>	NONE (OFF1, OFF2, OFF3)
<b>Acknowledge:</b>	IMMEDIATELY (POWER ON)
<b>Cause:</b>	One of the filter natural frequencies is greater than the Shannon frequency. The Shannon frequency is calculated according to the following formula: $0.5 / p0115[0]$ Fault value (r0949, interpret hexadecimal): Bit 0: Filter 1 (p1658, p1660) Bit 1: Filter 2 (p1663, p1665) Bit 2: Filter 3 (p1668, p1670) Bit 3: Filter 4 (p1673, p1675) Bit 8 ... 15: Data set number (starting from zero).
<b>Remedy:</b>	- reduce the numerator or denominator natural frequency of the current setpoint filter involved. - reduce the current controller sampling time (p0115[0]). - switch-out the filter involved (p1656).
<b>F07421</b>	<b>Drive: Speed setpoint filter natural frequency &gt; Shannon frequency</b>
<b>Reaction:</b>	NONE (OFF1, OFF2, OFF3)
<b>Acknowledge:</b>	IMMEDIATELY (POWER ON)
<b>Cause:</b>	One of the filter natural frequencies is greater than the Shannon frequency. The Shannon frequency is calculated according to the following formula: $0.5 / p0115[1]$ Fault value (r0949, interpret hexadecimal): Bit 0: Filter 1 (p1417, p1419) Bit 1: Filter 2 (p1423, p1425) Bit 8 ... 15: Data set number (starting from zero).
<b>Remedy:</b>	- reduce the numerator or denominator natural frequency of the speed setpoint filter involved. - reduce the speed controller sampling time (p0115[1]). - switch-out the filter involved (p1414).
<b>F07422</b>	<b>Drive: Reference model natural frequency &gt; Shannon frequency</b>
<b>Reaction:</b>	NONE (OFF1, OFF2, OFF3)
<b>Acknowledge:</b>	IMMEDIATELY (POWER ON)
<b>Cause:</b>	The natural filter frequency of the PT2 element for the reference model (p1433) is greater than the Shannon frequency. The Shannon frequency is calculated according to the following formula: $0.5 / p0115[1]$
<b>Remedy:</b>	- reduce the natural frequency of PT2 element for reference model (p1433). - reduce the speed controller sampling time (p0115[1]).

<b>F07423</b>	<b>Drive: APC filter natural frequency &gt; Shannon frequency</b>
<b>Reaction:</b>	NONE (OFF1, OFF2, OFF3)
<b>Acknowledge:</b>	IMMEDIATELY (POWER ON)
<b>Cause:</b>	One of the filter natural frequencies is greater than the Shannon frequency. The Shannon frequency is calculated according to the following formula: $0.5 / (p0115[1] * x)$ Fault value (r0949, interpret hexadecimal): Bit 0: Filter 1.1 (p3711, p3713), x = 1 Bit 4: Filter 2.1 (p3721, p3723), x = p3706 Bit 5: Filter 2.2 (p3726, p3728), x = p3706 Bit 8: Filter 3.1 (p3731, p3733), x = p3707 Bit 9: Filter 3.2 (p3736, p3738), x = p3707 Bit 16 ... 32: Data set number (starting from zero)
<b>Remedy:</b>	- reduce the numerator or denominator natural frequency of the filter involved. - reduce the speed controller sampling time (p0115[1]) or the sub-sampling (p3706, p3707). - switch-out the filter involved (p3704).
<b>A07424</b>	<b>Drive: Operating condition for APC not valid</b>
<b>Reaction:</b>	NONE
<b>Acknowledge:</b>	NONE
<b>Cause:</b>	The APC function (Advanced Positioning Control) has identified an invalid operating condition. Alarm value (r2124, interpret hexadecimal): Bit 0 = 1: APC is operating without encoder (sensorless). Bit 1 = 1: The load measuring system for APC, selected using p3701, has a fault. The APC function is disabled. Bit 2 = 1: The load measuring system for APC, selected using p3701, has a fault. The pulse de-coupling is disabled, i.e. the speed of the motor measuring system is used as speed for the closed-loop motor speed control.
<b>Remedy:</b>	Re bit 0: Only use the APC function in operation with an encoder. Re Bit 1, 2: Check the load measuring system.
<b>F07429</b>	<b>Drive: DSC without encoder not possible</b>
<b>Reaction:</b>	OFF2
<b>Acknowledge:</b>	IMMEDIATELY (POWER ON)
<b>Cause:</b>	The function DSC (Dynamic Servo Control) was activated although there is no encoder. See also: p1191 (DSC position controller gain KPC)
<b>Remedy:</b>	If there is no encoder and CI: p1191 (DSC position controller gain) is interconnected, then connector input CI: p1191 must have a 0 signal.
<b>F07430</b>	<b>Drive: Changeover to open-loop torque controlled operation not possible</b>
<b>Reaction:</b>	OFF2 (NONE, OFF1, OFF3)
<b>Acknowledge:</b>	IMMEDIATELY
<b>Cause:</b>	For sensorless operation, the converter cannot change over to closed-loop torque-controlled operation (BI: p1501).
<b>Remedy:</b>	Do not attempt to cover over to closed-loop torque-controlled operation.
<b>F07431</b>	<b>Drive: Changeover to sensorless operation not possible</b>
<b>Reaction:</b>	OFF2 (OFF1)
<b>Acknowledge:</b>	IMMEDIATELY
<b>Cause:</b>	For closed-loop torque control, the converter cannot change over to sensorless operation (p1404).
<b>Remedy:</b>	Do not attempt to change over to sensorless operation.

<b>F07432</b>	<b>Drive: Synchronous motor without overvoltage protection</b>
<b>Reaction:</b>	OFF2 (OFF1)
<b>Acknowledge:</b>	IMMEDIATELY
<b>Cause:</b>	Under voltage conditions, a synchronous motor can generate an overvoltage condition that can destroy the drive system. Fault value (r0949, interpret hexadecimal): Associated Drive Data Set (DDS).
<b>Remedy:</b>	Overvoltage protection can be implemented in the following ways: - limit the maximum speed (p1082) without any additional protection. The maximum speed without protection is calculated as follows: Rotary motors: $p1082[\text{RPM}] \leq 9590/p0316[\text{Nm/A}]$ Linear motors: $p1082 [\text{m/min}] \leq 60257.45/p0316 [\text{N/A}]$ - use a voltage protection module (VPM) in conjunction with the function "safe standstill" (p9601, p9801). When a fault condition exists, the VPM short-circuits the motors. During the short-circuit, the pulses must be cancelled - this means that the terminals for the safe standstill must be connected to the VPM. When using a VPM, p0643 must be set to 1. - activating the internal voltage protection (IVP) with p1231 = 3. See also: p0643 (Overvoltage protection for synchronous motors), p1231 (Configuration, armature short-circuit)
<b>F07433</b>	<b>Drive: Closed-loop control with encoder is not possible as the encoder has not been unparked</b>
<b>Reaction:</b>	NONE (OFF1, OFF2, OFF3)
<b>Acknowledge:</b>	IMMEDIATELY
<b>Cause:</b>	The changeover to closed-loop control with encoder is not possible as the encoder has not been unparked.
<b>Remedy:</b>	- check whether the encoder firmware supports the "parking" function (r0481.6 = 1). - upgrade the firmware. Note: For long-stator motors (p3870.0 = 1), the following applies: The encoder must have completed the unparking procedure (r3875.0 = 1) before a changeover can be made to closed-loop control with encoder. The encoder is unparked with a 0/1 edge at BI: p3876 and remains unparked until a 0 signal is again present.
<b>F07434</b>	<b>Drive: It is not possible to change the direction using p1821 with the pulses enabled</b>
<b>Reaction:</b>	OFF2
<b>Acknowledge:</b>	IMMEDIATELY
<b>Cause:</b>	A drive data set was selected - with the pulses enabled - that has a different parameterized direction (p1821). It is only possible to change the motor direction using p1821 when the pulses are inhibited.
<b>Remedy:</b>	- change over the drive data set with the pulses inhibited. - ensure that the changeover to a drive data set does not result in the motor direction of rotation being reversed (i.e. for these drive data sets, the same value must be in p1821). See also: p1821 (Direction reversal)
<b>F07435 (N)</b>	<b>Drive: Setting the ramp-function generator for sensorless vector control</b>
<b>Reaction:</b>	OFF2 (DCBRAKE, NONE, OFF1, OFF3)
<b>Acknowledge:</b>	IMMEDIATELY
<b>Cause:</b>	Only for vector drives (refer to r0107): During operation with sensorless vector control (r1407 bit1), the ramp-function generator was held (p1141) or bypassed (p1122) so that an internal setting command of the ramp-function generator output caused the speed setpoint to be frozen or was not able to be implemented.
<b>Remedy:</b>	- de-activate the holding command for the ramp-function generator (p1141). - do not bypass the ramp-function generator (p1122). - suppress the fault message (p2101, p2119). This is necessary if the ramp-function generator is held using jogging and the speed setpoint is simultaneously inhibited (0898 bit 6). Note: For sensorless vector control it is not practical to read-in the main setpoint of the speed control via p1155 or p1160 (also refer to p0922). In this case, the main setpoint should be injected before the ramp-function generator (refer to p1070). The reason for this is that the ramp-function generator output is automatically set when transitioning from closed-loop speed controlled into open-loop speed controlled operation.
<b>Reaction upon N:</b>	NONE
<b>Acknowledge upon N:</b>	NONE

**F07450 LR: Standstill monitoring has responded**  
**Reaction:** OFF1 (OFF2, OFF3)  
**Acknowledge:** IMMEDIATELY  
**Cause:** After the standstill monitoring time (p2543) expired, the drive left the standstill window (p2542).  
 - position actual value inversion incorrectly set (p0410).  
 - standstill window set too small (p2542).  
 - standstill monitoring time set too low (p2543).  
 - position loop gain too low (p2538).  
 - position loop gain too high (instability/oscillation, p2538).  
 - mechanical overload.  
 - check the connecting cable, motor/drive converter (phase missing, interchange).  
 - when selecting motor identification, select tracking operation (BI: p2655[0] = 1 signal).  
 - when selecting function generator, select tracking operation (BI: p2655[0] = 1 signal) and de-activate position control (BI:p2550 = 0 signal).  
**Remedy:** Check the causes and resolve.

**F07451 LR: Position monitoring has responded**  
**Reaction:** OFF1 (OFF2, OFF3)  
**Acknowledge:** IMMEDIATELY  
**Cause:** When the position monitoring time (p2545) expired, the drive had still not reached the positioning window (p2544).  
 - positioning window parameterized too small (p2544).  
 - position monitoring time parameterized too short (p2545).  
 - position loop gain too low (p2538).  
 - position loop gain too high (instability/oscillation, p2538).  
 - drive mechanically locked.  
**Remedy:** Check the causes and resolve.

**F07452 (A) LR: Following error too high**  
**Reaction:** OFF1 (OFF2, OFF3)  
**Acknowledge:** IMMEDIATELY  
**Cause:** The difference between the position setpoint position actual value (following error dynamic model, r2563) is greater than the tolerance (p2546).  
 - the drive torque or accelerating capacity exceeded.  
 - position measuring system fault.  
 - position control sense incorrect.  
 - mechanical system locked.  
 - excessively high traversing velocity or excessively high position reference value (setpoint) differences  
**Remedy:** Check the causes and resolve.  
**Reaction upon A:** NONE  
**Acknowledge upon A:** NONE

**F07453 LR: Position actual value conditioning error**  
**Reaction:** OFF1 (OFF2, OFF3)  
**Acknowledge:** IMMEDIATELY  
**Cause:** An error has occurred during the position actual value conditioning.  
**Remedy:** Check the encoder for the position actual value conditioning.  
 See also: p2502 (LR encoder assignment)

**A07454 EPOS: Position actual value conditioning does not have a valid encoder**  
**Reaction:** NONE  
**Acknowledge:** NONE  
**Cause:** One of the following problems has occurred with the position actual value conditioning:  
 - an encoder is not assigned for the position actual value conditioning (p2502 = 0).  
 - an encoder is assigned, but no encoder data set (p0187 = 99 or p0188 = 99 or p0189 = 99).  
 - an encoder an an encoder data set have been assigned, however, the encoder data set does not contain any encoder data (p0400 = 0) or invalid data (e.g. p0408 = 0).

**Remedy:** Check the drive data sets, encoder data sets and encoder assignment.  
See also: p0187 (Encoder 1 encoder data set number), p0188 (Encoder 2 encoder data set number), p0189 (Encoder 3 encoder data set number), p0400 (Enc type selection), p2502 (LR encoder assignment)

**A07455 EPOS: Maximum velocity limited**

**Reaction:** NONE

**Acknowledge:** NONE

**Cause:** The maximum velocity (p2571) is too high to correctly calculate the modulo correction. Within the sampling time for positioning (p0115[5]), with the maximum velocity, a maximum of the half modulo length must be moved through. p2571 was limited to this value.

**Remedy:** - reduce the maximum velocity (p2571).  
- increase the sampling time for positioning (p0115[5]).

**A07456 EPOS: Setpoint velocity limited**

**Reaction:** NONE

**Acknowledge:** NONE

**Cause:** The actual setpoint velocity is greater than the parameterized maximum velocity (p2571) and is therefore limited.

**Remedy:** - check the entered setpoint velocity.  
- reduce the velocity override (CI: p2646).  
- increase the maximum velocity (p2571).

**A07457 EPOS: Combination of input signals illegal**

**Reaction:** NONE

**Acknowledge:** NONE

**Cause:** An illegal combination of input signals that are simultaneously set was identified.  
Alarm value (r2124, decimal):  
0: Jogging 1 and jogging 2 (p2589, p2590).  
1: Jogging 1 or jogging 2 and direct setpoint input/MDI (p2589, p2590, p2647).  
2: Jogging 1 or jogging 2 and start referencing (p2589, p2590, p2595).  
3: Jogging 1 or jogging 2 and activate traversing task (p2589, p2590, p2631).  
4: Direct setpoint input/MDI and starting referencing (p2647, p2595).  
5: Direct setpoint input/MDI and activate traversing task (p2647, p2631).  
6: Start referencing and activate traversing task (p2595, p2631).

**Remedy:** Check the appropriate input signals and correct.

**F07458 EPOS: Reference cam not found**

**Reaction:** OFF1 (OFF2, OFF3)

**Acknowledge:** IMMEDIATELY

**Cause:** After starting the search for reference, the axis moved through the maximum permissible distance to search for the reference cam without actually finding the reference cam.

**Remedy:** - check the "reference cam" binector input (BI: p2612).  
- check the maximum permissible distance to the reference cam (p2606).  
- if axis does not have any reference cam, then set p2607 to 0.  
See also: p2606 (EPOS search for reference, reference cam, maximum distance), p2607 (EPOS search for reference, reference cam present), p2612 (EPOS search for reference, reference cam)

**F07459 EPOS: No zero mark**

**Reaction:** OFF1 (OFF2, OFF3)

**Acknowledge:** IMMEDIATELY

**Cause:** After leaving the reference cam, the axis has traversed the maximum permissible distance between the reference cam and zero mark without finding the zero mark.

**Remedy:** - check the encoder regarding the zero mark  
- check the maximum permissible distance between the reference cam and zero mark (p2609).  
- use an external encoder zero mark (equivalent zero mark) (p0495).  
See also: p0495 (Equivalent zero mark, input terminal), p2609 (EPOS search for reference, max. distance ref. cam and zero mark)

<b>F07460</b>	<b>EPOS: End of reference cam not found</b>
<b>Reaction:</b>	OFF1 (OFF2, OFF3)
<b>Acknowledge:</b>	IMMEDIATELY
<b>Cause:</b>	During the search for reference, when the axis reached the zero mark it also reached the end of the traversing range without detecting an edge at the binector input "reference cam" (BI: p2612). Maximum traversing range: -2147483648 [LU] ... -2147483647 [LU]
<b>Remedy:</b>	- check the "reference cam" binector input (BI: p2612). - repeat the search for reference. See also: p2612 (EPOS search for reference, reference cam)
<b>A07461</b>	<b>EPOS: Reference point not set</b>
<b>Reaction:</b>	NONE
<b>Acknowledge:</b>	NONE
<b>Cause:</b>	When starting a traversing block, a reference point is not set (r2684.11 = 0).
<b>Remedy:</b>	Reference the system (search for reference, flying referencing, set reference point).
<b>A07462</b>	<b>EPOS: Selected traversing block number does not exist</b>
<b>Reaction:</b>	NONE
<b>Acknowledge:</b>	NONE
<b>Cause:</b>	A traversing block was selected using an edge of the binector input "activate traversing block (0 -> 1)" (BI: p2631) and is not available. Alarm value (r2124, decimal): Number of the selected traversing block that is also not available.
<b>Remedy:</b>	- correct the traversing program. - select an available traversing block number.
<b>F07464</b>	<b>EPOS: Traversing block is inconsistent</b>
<b>Reaction:</b>	OFF1 (OFF2, OFF3)
<b>Acknowledge:</b>	IMMEDIATELY
<b>Cause:</b>	The traversing block does not contain valid information. Alarm value (r2124, decimal): Number of the traversing block with invalid information.
<b>Remedy:</b>	Check the traversing block and where relevant, take into consideration alarms that are present.
<b>A07465</b>	<b>EPOS: Traversing block does not have a subsequent block</b>
<b>Reaction:</b>	NONE
<b>Acknowledge:</b>	NONE
<b>Cause:</b>	There is no subsequent block in the traversing block. Alarm value (r2124, decimal): Number of the traversing block with the missing subsequent block.
<b>Remedy:</b>	- parameterize this traversing block with the block change enable END. - parameterize additional traversing blocks with a higher block number and for the last block, using the block change enable END.
<b>A07466</b>	<b>EPOS: Traversing block number assigned a multiple number of times</b>
<b>Reaction:</b>	NONE
<b>Acknowledge:</b>	NONE
<b>Cause:</b>	The same traversing block number was assigned a multiple number of times. Alarm value (r2124, decimal): Number of the traversing block that was assigned a multiple number of times.
<b>Remedy:</b>	Correct the traversing blocks.

<b>A07467</b>	<b>EPOS: Traversing block has illegal task parameters</b>
<b>Reaction:</b>	NONE
<b>Acknowledge:</b>	NONE
<b>Cause:</b>	The task parameter in the traversing block contains an illegal value. Alarm value (r2124, decimal): Number of the traversing block with an illegal task parameter.
<b>Remedy:</b>	Correct the task parameter in the traversing block.
<b>A07468</b>	<b>EPOS: Traversing block jump destination does not exist</b>
<b>Reaction:</b>	NONE
<b>Acknowledge:</b>	NONE
<b>Cause:</b>	In a traversing block, a jump was programmed to a non-existent block. Alarm value (r2124, decimal): Number of the traversing block with a jump destination that does not exist.
<b>Remedy:</b>	- correct the traversing block. - add the missing traversing block.
<b>A07469</b>	<b>EPOS: Traversing block &lt; target position &lt; software limit switch minus</b>
<b>Reaction:</b>	NONE
<b>Acknowledge:</b>	NONE
<b>Cause:</b>	In the traversing block the specified absolute target position lies outside the range limited by the software limit switch minus. Alarm value (r2124, decimal): Number of the traversing block with illegal target position.
<b>Remedy:</b>	- correct the traversing block. - change software limit switch minus (CI: p2578, p2580).
<b>A07470</b>	<b>EPOS: Traversing block &gt; target position &gt; software limit switch plus</b>
<b>Reaction:</b>	NONE
<b>Acknowledge:</b>	NONE
<b>Cause:</b>	In the traversing block the specified absolute target position lies outside the range limited by the software limit switch plus. Alarm value (r2124, decimal): Number of the traversing block with illegal target position.
<b>Remedy:</b>	- correct the traversing block. - change software limit switch plus (CI: p2579, p2581).
<b>A07471</b>	<b>EPOS: Traversing block target position outside the modulo range</b>
<b>Reaction:</b>	NONE
<b>Acknowledge:</b>	NONE
<b>Cause:</b>	In the traversing block the target position lies outside the modulo range. Alarm value (r2124, decimal): Number of the traversing block with illegal target position.
<b>Remedy:</b>	- in the traversing block, correct the target position. - change the modulo range (p2576).
<b>A07472</b>	<b>EPOS: Traversing block ABS_POS/ABS_NEG not possible</b>
<b>Reaction:</b>	NONE
<b>Acknowledge:</b>	NONE
<b>Cause:</b>	In the traversing block the positioning mode ABS_POS or ABS_NEG were parameterized with the modulo correction not activated. Alarm value (r2124, decimal): Number of the traversing block with the illegal positioning mode.
<b>Remedy:</b>	Correct the traversing block.

<b>A07473 (F)</b>	<b>EPOS: Beginning of traversing range reached</b>
<b>Reaction:</b>	NONE
<b>Acknowledge:</b>	NONE
<b>Cause:</b>	When traversing, the axis has moved to the traversing range limit.
<b>Remedy:</b>	Move away in the positive direction.
Reaction upon F:	OFF1 (OFF2, OFF3)
Acknowledge upon F:	IMMEDIATELY
<b>A07474 (F)</b>	<b>EPOS: End of traversing range reached</b>
<b>Reaction:</b>	NONE
<b>Acknowledge:</b>	NONE
<b>Cause:</b>	When traversing, the axis has moved to the traversing range limit.
<b>Remedy:</b>	Move away in the negative direction.
Reaction upon F:	OFF1 (OFF2, OFF3)
Acknowledge upon F:	IMMEDIATELY
<b>F07475 (A)</b>	<b>EPOS: Target position &lt; start of traversing range</b>
<b>Reaction:</b>	OFF1 (OFF2, OFF3)
<b>Acknowledge:</b>	IMMEDIATELY
<b>Cause:</b>	The target position for relative traversing lies outside the traversing range.
<b>Remedy:</b>	Correct the target position.
Reaction upon A:	NONE
Acknowledge upon A:	NONE
<b>F07476 (A)</b>	<b>EPOS: Target position &gt; end of the traversing range</b>
<b>Reaction:</b>	OFF1 (OFF2, OFF3)
<b>Acknowledge:</b>	IMMEDIATELY
<b>Cause:</b>	The target position for relative traversing lies outside the traversing range.
<b>Remedy:</b>	Correct the target position.
Reaction upon A:	NONE
Acknowledge upon A:	NONE
<b>A07477 (F)</b>	<b>EPOS: Target position &lt; software limit switch minus</b>
<b>Reaction:</b>	NONE
<b>Acknowledge:</b>	NONE
<b>Cause:</b>	In the actual traversing operation, the target position is less than the software limit switch minus.
<b>Remedy:</b>	- correct the target position. - change software limit switch minus (CI: p2578, p2580). See also: p2578 (EPOS software limit switch minus signal source), p2580 (EPOS software limit switch minus), p2582 (EPOS software limit switch activation)
Reaction upon F:	OFF1 (OFF2, OFF3)
Acknowledge upon F:	IMMEDIATELY



<b>A07478 (F)</b>	<b>EPOS: Target position &gt; software limit switch plus</b>
<b>Reaction:</b>	NONE
<b>Acknowledge:</b>	NONE
<b>Cause:</b>	In the actual traversing operation, the target position is greater than the software limit switch plus.
<b>Remedy:</b>	- correct the target position. - change software limit switch plus (CI: p2579, p2581). See also: p2579 (EPOS software limit switch plus signal source), p2581 (EPOS software limit switch plus), p2582 (EPOS software limit switch activation)
Reaction upon F:	OFF1 (OFF2, OFF3)
Acknowledge upon F:	IMMEDIATELY
<b>A07479</b>	<b>EPOS: Software limit switch minus reached</b>
<b>Reaction:</b>	NONE
<b>Acknowledge:</b>	NONE
<b>Cause:</b>	The axis is at the position of the software limit switch minus. An active traversing block was interrupted.
<b>Remedy:</b>	- correct the target position. - change software limit switch minus (CI: p2578, p2580). See also: p2578 (EPOS software limit switch minus signal source), p2580 (EPOS software limit switch minus), p2582 (EPOS software limit switch activation)
<b>A07480</b>	<b>EPOS: Software limit switch plus reached</b>
<b>Reaction:</b>	NONE
<b>Acknowledge:</b>	NONE
<b>Cause:</b>	The axis is at the position of the software limit switch plus. An active traversing block was interrupted.
<b>Remedy:</b>	- correct the target position. - change software limit switch plus (CI: p2579, p2581). See also: p2579 (EPOS software limit switch plus signal source), p2581 (EPOS software limit switch plus), p2582 (EPOS software limit switch activation)
<b>F07481 (A)</b>	<b>EPOS: Axis position &lt; software limit switch minus</b>
<b>Reaction:</b>	OFF1 (OFF2, OFF3)
<b>Acknowledge:</b>	IMMEDIATELY
<b>Cause:</b>	The actual position of the axis is less than the position of the software limit switch minus.
<b>Remedy:</b>	- correct the target position. - change software limit switch minus (CI: p2578, p2580). See also: p2578 (EPOS software limit switch minus signal source), p2580 (EPOS software limit switch minus), p2582 (EPOS software limit switch activation)
Reaction upon A:	NONE
Acknowledge upon A:	NONE
<b>F07482 (A)</b>	<b>EPOS: Axis position &gt; software limit switch plus</b>
<b>Reaction:</b>	OFF1 (OFF2, OFF3)
<b>Acknowledge:</b>	IMMEDIATELY
<b>Cause:</b>	The actual position of the axis is greater than the position of the software limit switch plus.
<b>Remedy:</b>	- correct the target position. - change software limit switch plus (CI: p2579, p2581). See also: p2579 (EPOS software limit switch plus signal source), p2581 (EPOS software limit switch plus), p2582 (EPOS software limit switch activation)
Reaction upon A:	NONE
Acknowledge upon A:	NONE

<b>A07486</b>	<b>EPOS: Intermediate stop missing</b>
<b>Reaction:</b>	NONE
<b>Acknowledge:</b>	NONE
<b>Cause:</b>	In the modes "traversing blocks" or "direct setpoint input/MDI" at the start of motion, the binector input "no intermediate stop/intermediate stop" (BI: p2640) did not have a 1 signal.
<b>Remedy:</b>	Connect a 1 signal to the binector input "no intermediate stop/intermediate stop" (BI: p2640) and re-start motion.
<b>A07487</b>	<b>EPOS: Reject traversing task missing</b>
<b>Reaction:</b>	NONE
<b>Acknowledge:</b>	NONE
<b>Cause:</b>	In the modes "traversing blocks" or "direct setpoint input/MDI" at the start of motion, the binector input "do not reject traversing task/reject traversing task" (BI: p2641) does not have a 1 signal.
<b>Remedy:</b>	Connect a 1 signal to the binector input "do not reject traversing task/reject traversing task" (BI: p2641) and re-start motion.
<b>F07488</b>	<b>EPOS: Relative positioning not possible</b>
<b>Reaction:</b>	OFF1 (OFF2, OFF3)
<b>Acknowledge:</b>	IMMEDIATELY
<b>Cause:</b>	In the mode "direct setpoint input/MDI", for continuous transfer (p2649 = 1) relative positioning was selected (BI: p2648 = 0 signal).
<b>Remedy:</b>	Check the control.
<b>A07489</b>	<b>EPOS: Reference point correction (offset) outside the window</b>
<b>Reaction:</b>	NONE
<b>Acknowledge:</b>	NONE
<b>Cause:</b>	For the function "flying referencing" the difference between the measured position at the measuring probe and the reference point coordinate lies outside the parameterized window.
<b>Remedy:</b>	- check the mechanical system. - check the parameterization of the window (p2602).
<b>F07490</b>	<b>EPOS: Enable signal withdrawn while traversing</b>
<b>Reaction:</b>	OFF1 (OFF2, OFF3)
<b>Acknowledge:</b>	IMMEDIATELY
<b>Cause:</b>	- for a standard assignment, another fault may have occurred as a result of withdrawing the enable signals. - the drive is in the "power-on inhibit" state (for a standard assignment).
<b>Remedy:</b>	- set the enable signals or check the cause of the fault that first occurred and then result (for a standard assignment). - check the assignment to enable the basic positioning function.
<b>F07491 (A)</b>	<b>EPOS: STOP cam minus reached</b>
<b>Reaction:</b>	NONE
<b>Acknowledge:</b>	IMMEDIATELY
<b>Cause:</b>	A zero signal was detected at binector input BI: p2569, i.e. the STOP cam minus was reached.
<b>Remedy:</b>	Leave the STOP cam minus in the positive traversing direction and return the axis to the valid traversing range.
<b>Reaction upon A:</b>	NONE
<b>Acknowledge upon A:</b>	NONE
<b>F07492 (A)</b>	<b>EPOS: STOP cam plus reached</b>
<b>Reaction:</b>	NONE
<b>Acknowledge:</b>	IMMEDIATELY
<b>Cause:</b>	A zero signal was detected at binector input BI: p2570, i.e. the STOP cam plus was reached.
<b>Remedy:</b>	Leave the STOP cam plus in the negative traversing direction and return the axis to the valid traversing range.
<b>Reaction upon A:</b>	NONE
<b>Acknowledge upon A:</b>	NONE

<b>F07493</b>	<b>LR: Overflow of the value range for the position actual value</b>
<b>Reaction:</b>	OFF1 (OFF2, OFF3)
<b>Acknowledge:</b>	IMMEDIATELY
<b>Cause:</b>	The value range (-2147483648 ... 2147483647) for the position actual value representation was exceeded. When the overflow occurs, the status "referenced" or the status "adjustment absolute measuring system" is reset. Fault value (r0949, decimal): 1: r2521 has exceeded the value range for the position actual value display. 2: r483 has exceeded the value range for the position actual value display.
<b>Remedy:</b>	If required, reduce the traversing range or position resolution.
<b>F07494</b>	<b>LR: DDS changeover in operation</b>
<b>Reaction:</b>	OFF1 (OFF2, OFF3)
<b>Acknowledge:</b>	IMMEDIATELY
<b>Cause:</b>	A drive data set changeover (DDS) with a change of the mechanical relationships and the encoder assignment (p2502) was requested in operation.
<b>Remedy:</b>	To changeover the drive data set, initially, exit the "operation" mode.
<b>A07495 (F)</b>	<b>LR: Reference function interrupted</b>
<b>Reaction:</b>	NONE
<b>Acknowledge:</b>	NONE
<b>Cause:</b>	An activated reference function (reference mark search or measuring probe evaluation) was interrupted. - an encoder fault has occurred (Gn_ZSW.15 = 1). - position actual value was set during an activated reference function. - simultaneously activate reference mark search and measuring probe evaluation (BI: p2508 and BI: p2509 = 1 signal). - activated reference function (reference mark search or measuring probe evaluation) was de-activated (BI: p2508 and BI: p2509 = 0 signal).
<b>Remedy:</b>	- check the causes and resolve. - reset the control (BI: p2508 and BI: p2509 = 0 signal) and activate the requested function.
Reaction upon F:	OFF1 (OFF2, OFF3)
Acknowledge upon F:	IMMEDIATELY
<b>A07496</b>	<b>EPOS: Enable not possible</b>
<b>Reaction:</b>	NONE
<b>Acknowledge:</b>	NONE
<b>Cause:</b>	It is not possible to enable the basic positioner for the following reasons. Alarm value (r2124, decimal): 1: EPOS enable missing (BI: p2656). 2: Position actual value, valid feedback signal missing (BI: p2658). See also: p2656 (EPOS enable basic positioner), p2658 (EPOS pos. actual value valid, feedback signal)
<b>Remedy:</b>	Check the appropriate binector inputs and signals.
<b>A07497</b>	<b>LR: Position setting value activated</b>
<b>Reaction:</b>	NONE
<b>Acknowledge:</b>	NONE
<b>Cause:</b>	The position actual value is set to the value received via CI: p2515 while BI: p2514 = 1 signal. A possible system deviation cannot be corrected.
<b>Remedy:</b>	None necessary. The alarm automatically disappears with BI: p2514 = 0 signal.

<b>F07500</b>	<b>Drive: Power unit data set PDS not configured</b>
<b>Reaction:</b>	NONE
<b>Acknowledge:</b>	IMMEDIATELY
<b>Cause:</b>	Only for controlled line supply infeed/regenerative feedback units: The power unit data set was not configured - this means that a data set number was not entered into the drive data set. Fault value (r0949, decimal): Drive data set number of p0185.
<b>Remedy:</b>	The index of the power unit data set associated with the drive data set should be entered into p0185.
<b>F07501</b>	<b>Drive: Motor Data Set MDS not configured</b>
<b>Reaction:</b>	NONE
<b>Acknowledge:</b>	IMMEDIATELY
<b>Cause:</b>	Only for power units: The motor data set was not configured - this means that a data set number was not entered into the associated drive data set. Fault value (r0949, decimal): The fault value includes the drive data set number of p0186.
<b>Remedy:</b>	The index of the motor data set associated with the drive data set should be entered into p0186. See also: p0186 (Motor Data Sets (MDS) number)
<b>F07502</b>	<b>Drive: Encoder Data Set EDS not configured</b>
<b>Reaction:</b>	NONE
<b>Acknowledge:</b>	IMMEDIATELY
<b>Cause:</b>	Only for power units: The encoder data set was not configured - this means that a data set number was not entered into the associated drive data set. Fault value (r0949, decimal): The fault value includes the drive data set number of p0187, p0188 and p0189. The fault value is increased by 100 * encoder number (e.g. for p0189: Fault value 3xx with xx = data set number).
<b>Remedy:</b>	The index of the encoder data set associated with the drive data set should be entered into p0187 (1st encoder), p0188 (2nd encoder) and p0189 (3rd encoder).
<b>A07504</b>	<b>Drive: Motor data set is not assigned to a drive data set</b>
<b>Reaction:</b>	NONE
<b>Acknowledge:</b>	NONE
<b>Cause:</b>	A motor data set is not assigned to a drive object. All of the existing motor data sets in the drive data sets must be assigned using the MDS number (p0186[0...n]). Alarm value (r2124, decimal): Number of the motor data set that has not been assigned.
<b>Remedy:</b>	In the drive data sets, assign the non-assigned motor data set using the MDS number (p0186[0...n]). See also: p0186 (Motor Data Sets (MDS) number)
<b>F07510</b>	<b>Drive: Identical encoder in the drive data set</b>
<b>Reaction:</b>	NONE
<b>Acknowledge:</b>	IMMEDIATELY
<b>Cause:</b>	More than one encoder with identical component number is assigned to a single drive data set. In one drive data set, it is not permissible that identical encoders are operated together. Fault value (r0949, decimal): 1000 * first identical encoder + 100 * second identical encoder + drive data set. Example: Fault value = 1203 means: In drive data set 3, the first (p0187[3]) and second encoder (p0188[3]) are identical.
<b>Remedy:</b>	Assign the drive data set to different encoders. See also: p0141 (Encoder interface (Sensor Module) component number), p0187 (Encoder 1 encoder data set number), p0188 (Encoder 2 encoder data set number), p0189 (Encoder 3 encoder data set number)

<b>F07511</b>	<b>Drive: Encoder used a multiple number of times</b>
<b>Reaction:</b>	NONE
<b>Acknowledge:</b>	IMMEDIATELY
<b>Cause:</b>	Each encoder may only be assigned to one drive and within a drive must - in each drive data set - either always be encoder 1, always encoder 2 or always encoder 3. This unique assignment has been violated. Fault value (r0949, decimal): The two parameters in coded form, that refer to the same component number. First parameter: Index: First and second decimal place (99 for EDS, not assigned DDS) Parameter number: Third decimal place (1 for p0187, 2 for p0188, 3 for p0189, 4 for EDS not assigned DDS) Drive number: Fourth and fifth decimal place Second parameter: Index: Sixth and seventh decimal place (99 for EDS, not assigned DDS) Parameter number: Eighth decimal place (1 for p0187, 2 for p0188, 3 for p0189, 4 for EDS, not assigned DDS) Drive number: Ninth and tenth decimal place See also: p0141 (Encoder interface (Sensor Module) component number)
<b>Remedy:</b>	Correct the double use of a component number using the two parameters coded in the fault value.
<b>A07512</b>	<b>Drive: Encoder data set changeover cannot be parameterized</b>
<b>Reaction:</b>	NONE
<b>Acknowledge:</b>	NONE
<b>Cause:</b>	Using p0141, a changeover of the encoder data set is prepared that is illegal. In this firmware release, an encoder data set changeover is only permitted for the components in the actual topology. Commissioning can only be exited with the correct parameterization. Alarm value (r2124, decimal): Incorrect EDS data set number. See also: p0187 (Encoder 1 encoder data set number), p0188 (Encoder 2 encoder data set number), p0189 (Encoder 3 encoder data set number)
<b>Remedy:</b>	Every encoder data set must be assigned its own dedicated DRIVE-CLiQ socket. The component numbers of the encoder interfaces (p0141) must have different values within a drive object. The following must apply: p0141[0] not equal to p0141[1] not equal to ... not equal to p0141[n]
<b>A07514</b>	<b>Drive: Data structure does not correspond to the interface module</b>
<b>Reaction:</b>	NONE
<b>Acknowledge:</b>	NONE
<b>Cause:</b>	The interface mode "SIMODRIVE 611 universal" was set (p2038 = 1) and the data structure does not correspond to this mode. For the data structure, the following rule must be complied with. Within the group of 8 drive data sets, the assignment to the motor data set must be set the same: p0186[0] = p0186[1] = ... = p0186[7] p0186[8] = p0186[9] = ... = p0186[15] p0186[16] = p0186[17] = ... = p0186[23] p0186[24] = p0186[25] = ... = p0186[31] See also: p0180 (Number of Drive Data Sets (DDS)), p0186 (Motor Data Sets (MDS) number), p2038 (PROFIBUS STW/ZSW interface mode)
<b>Remedy:</b>	- structure the data according to the rules of the "SIMODRIVE 611 universal" interface mode. - check the interface mode (p2038).
<b>A07515</b>	<b>Drive: Power unit and motor incorrectly connected</b>
<b>Reaction:</b>	NONE
<b>Acknowledge:</b>	NONE
<b>Cause:</b>	A power unit (via PDS) was assigned to a motor (via MDS) in a drive data set that is not connected in the target topology. Alarm value (r2124, decimal): Number of the incorrectly parameterized drive data set.
<b>Remedy:</b>	- assign the drive data set to a combination of motor and power unit permitted by the target topology. - adapt the target topology. See also: p0121 (Power unit component number), p0131 (Motor component number), p0186 (Motor Data Sets (MDS) number)

<b>F07516</b>	<b>Drive: Re-commission the data set</b>
<b>Reaction:</b>	NONE
<b>Acknowledge:</b>	IMMEDIATELY
<b>Cause:</b>	The assignment between the drive data set and motor data set (p0186) or between the drive data set and the encoder data set was modified (p0187). This is the reason that the drive data set must re-commissioned. Fault value (r0949, decimal): Drive data set to be re-commissioned.
<b>Remedy:</b>	Commission the drive data set specified in the fault value (r0949).
<b>A07517</b>	<b>Drive: Encoder data set changeover incorrectly parameterized</b>
<b>Reaction:</b>	NONE
<b>Acknowledge:</b>	NONE
<b>Cause:</b>	An MDS cannot have different motor encoders in two different DDS. The following parameterization therefore results in an error: p0186[0] = 0 p0187[0] = 0 p0186[0] = 0 p0187[0] = 1 Alarm value (r2124, decimal): The lower 16 bits indicate the first DDS and the upper 16 bits indicate the second DDS.
<b>Remedy:</b>	If you wish to operate a motor once with one motor encoder and then another time with the other motor encoder, then you must set-up two different MDSs, in which the motor data are the same. Example: p0186[0] = 0 p0187[0] = 0 p0186[0] = 1 p0187[0] = 1
<b>F07518</b>	<b>Drive: Motor data set changeover incorrectly parameterized</b>
<b>Reaction:</b>	NONE
<b>Acknowledge:</b>	IMMEDIATELY
<b>Cause:</b>	The system has identified that two motor data sets were incorrectly parameterized. Parameter r0313 (calculated from p0314, p0310, p0311), r0315 and p1982 may only have different values if the motor data sets are assigned different motors. p0827 is used to assign the motors and/contactors. It is not possible to toggle between motor data sets. Alarm value (r2124, interpret hexadecimal): xxxxyyyy: xxxx: First DDS with assigned MDS, yyyy: Second DDS with assigned MDS
<b>Remedy:</b>	Correct the parameterization of the motor data sets.
<b>A07519</b>	<b>Drive: Motor cannot be changed over</b>
<b>Reaction:</b>	NONE
<b>Acknowledge:</b>	NONE
<b>Cause:</b>	With the setting p0833.1, a motor changeover via the application is selected. This is the reason that p0827 must have different values in the appropriate motor data set. Alarm value (r2124, interpret hexadecimal): xxxxyyyy: xxxx: First MDS, yyyy: Second MDS
<b>Remedy:</b>	- parameterize the appropriate motor data sets differently (p0827). - select the setting p0833.0 = 0 (motor changeover via the drive).
<b>A07530</b>	<b>Drive: Drive Data Set DDS not present</b>
<b>Reaction:</b>	NONE
<b>Acknowledge:</b>	NONE
<b>Cause:</b>	The selected drive data set is not available (p0837 > p0180). The drive data set was not changed-over. See also: p0180 (Number of Drive Data Sets (DDS)), p0820 (Drive data set selection DDS bit 0), p0821 (Drive data set selection DDS bit 1), p0822 (Drive data set selection DDS bit 2), p0823 (Drive data set selection DDS bit 3), p0824 (Drive data set selection DDS bit 4), r0837 (Drive Data Set DDS selected)
<b>Remedy:</b>	- select the existing drive data set. - set-up additional drive data sets.

---

<b>A07541</b>	<b>Drive: Data set changeover not possible</b>
<b>Reaction:</b>	NONE
<b>Acknowledge:</b>	NONE
<b>Cause:</b>	The selected drive data set changeover and the assigned motor changeover are not possible and are not carried-out. For synchronous motors, the motor contactor may only be switched for actual speeds less than the speed at the start of field weakening (r0063 < p0348). See also: r0063 (Actual speed, smoothed), p0348 (Speed at the start of field weakening Vdc = 600 V)
<b>Remedy:</b>	Reduce the speed below the speed at the start of field weakening.

---

<b>A07550 (F, N)</b>	<b>Drive: Not possible to reset encoder parameters</b>
<b>Reaction:</b>	NONE
<b>Acknowledge:</b>	NONE
<b>Cause:</b>	When carrying-out a factory setting (e.g. using p0970 = 1), it was not possible to reset the encoder parameters. The encoder parameters are directly read out of the encoder via DRIVE-CLiQ. Alarm value (r2124, decimal): Component number of the encoder involved.
<b>Remedy:</b>	- repeat the operation. - check the DRIVE-CLiQ connection.
Reaction upon F:	NONE (DCBRAKE, OFF1, OFF2, OFF3, STOP1, STOP2)
Acknowledge upon F:	IMMEDIATELY (POWER ON)
Reaction upon N:	NONE
Acknowledge upon N:	NONE

---

<b>F07551</b>	<b>Drive encoder: No commutation angle information</b>
<b>Reaction:</b>	OFF2 (DCBRAKE)
<b>Acknowledge:</b>	IMMEDIATELY (POWER ON)
<b>Cause:</b>	The angular commutation information is missing. This means that synchronous motors cannot be controlled (closed-loop control) Fault value (r0949, decimal): Low word: Drive data set number High word: Cause: 1: The motor encoder used does not supply an absolute commutation angle. 2: The selected ratio of the measuring gearbox does not match the motor pole pair number
<b>Remedy:</b>	Re cause 1: - check the encoder parameterization (p0404). - use an encoder with track C/D, EnDat interface of Hall sensors. - use an encoder with sinusoidal A/B track for which the motor pole pair number (p0313) is an integer multiple of the encoder pulse number (p0408). - activate the pole position identification routine (p1982 = 1). Re cause 2: - the quotient of the pole pair number divided by the measuring gearbox ratio must be an integer number: (p0314*p0433) / p0432. See also: p0402 (Gearbox type selection), p0404 (Encoder configuration effective), p0432 (Gearbox factor, encoder revolutions), p0433 (Gearbox factor, motor/load revolutions)

<b>F07552 (A)</b>	<b>Drive encoder: Encoder configuration not supported</b>
<b>Reaction:</b>	OFF2 (DCBRAKE, NONE, OFF1, OFF3, STOP1, STOP2)
<b>Acknowledge:</b>	IMMEDIATELY (POWER ON)
<b>Cause:</b>	The requested encoder configuration is not supported. Only bits may be requested in p0404 that are signaled as being supported by the encoder evaluation in r0456. Fault value (r0949, decimal): Low word low byte: Encoder data set number Low word high byte: Component number High word: The encoder evaluation does not support a function selected in p0404. 1: sin/cos encoder with absolute track (this is supported by SME25). 3: Squarewave encoder (this is supported by SMC30). 4: sin/cos encoder (this is supported by SMC20, SMI20, SME20, SME25). 12: sin/cos encoder with reference mark (this is supported by SME20). 15: Commutation with zero mark for separately-excited synchronous motors with VECTORMV. 23: Resolver (this is supported by SMC10, SMI10). 65535: Other function (compare r0456 and p0404). See also: p0404 (Encoder configuration effective), r0456 (Encoder configuration supported)
<b>Remedy:</b>	- check the encoder parameterization (p0400, p0404). - use the matching encoder evaluation (r0456).
Reaction upon A:	NONE
Acknowledge upon A:	NONE
<b>F07553 (A)</b>	<b>Drive encoder: Sensor Module configuration not supported</b>
<b>Reaction:</b>	OFF2 (DCBRAKE, NONE, OFF1, OFF3, STOP1, STOP2)
<b>Acknowledge:</b>	IMMEDIATELY (POWER ON)
<b>Cause:</b>	The Sensor Module does not support the requested configuration. Possible causes: - bits are set in p0430 (requested functions) that are not set in r0458 (supported functions). This does not apply for bit 19 (safety position actual value sensing), bit 29 (phase correction), bit 30 (amplitude correction) and bit 31 (offset correction). - p1982 > 0 (pole position identification requested), but r0458 bit 16 = 0 (pole position identification not supported). Fault value (r0949, decimal): Encoder data set number.
<b>Remedy:</b>	- check the encoder parameterization (p0430). - check the pole position identification routine (p1982). - use the matching encoder evaluation (r0458).
Reaction upon A:	NONE
Acknowledge upon A:	NONE
<b>F07555 (A)</b>	<b>Drive encoder: Configuration position tracking</b>
<b>Reaction:</b>	OFF2 (DCBRAKE, NONE, OFF1, OFF3, STOP1, STOP2)
<b>Acknowledge:</b>	IMMEDIATELY (POWER ON)
<b>Cause:</b>	The configuration of the position tracking is not supported. Position tracking can only be activated for absolute encoders. Fault value (r0949, decimal): Low word low byte: Encoder data set number Low word high byte: Component number See also: p0404 (Encoder configuration effective), p0411 (Measuring gearbox, configuration)
<b>Remedy:</b>	- use an absolute encoder. - de-select position tracking (p0411).
Reaction upon A:	NONE
Acknowledge upon A:	NONE



---

<b>F07560</b>	<b>Drive encoder: Number of pulses is not to the power of two</b>
<b>Reaction:</b>	OFF2 (DCBRAKE, NONE, OFF1, OFF3, STOP1, STOP2)
<b>Acknowledge:</b>	IMMEDIATELY (POWER ON)
<b>Cause:</b>	For rotary absolute encoders, the pulse number in p0408 must be to the power of two. Fault value (r0949, decimal): The fault value includes the encoder data set number involved.
<b>Remedy:</b>	- check the parameterization (p0408, p0404.1, r0458.5). - if required, upgrade the Sensor Module firmware.

---

<b>F07561</b>	<b>Drive encoder: Number of multiturn pulses is not to the power of two</b>
<b>Reaction:</b>	OFF2 (DCBRAKE, NONE, OFF1, OFF3, STOP1, STOP2)
<b>Acknowledge:</b>	IMMEDIATELY (POWER ON)
<b>Cause:</b>	The multi-turn resolution in p0421 must be to the power of two. Fault value (r0949, decimal): The fault value includes the encoder data set number involved.
<b>Remedy:</b>	- check the parameterization (p0421, p0404.1, r0458.5). - if required, upgrade the Sensor Module firmware.

---

<b>A07565 (F, N)</b>	<b>Drive: Encoder error in PROFIdrive encoder interface 1</b>
<b>Reaction:</b>	NONE
<b>Acknowledge:</b>	NONE
<b>Cause:</b>	An encoder error was signaled for encoder 1 via the PROFIdrive encoder interface (G1_ZSW.15). Alarm value (r2124, decimal): Error code from G1_XIST2, refer to the description regarding r0483.
<b>Remedy:</b>	Acknowledge the encoder error using the encoder control word (G1_STW.15 = 1).
Reaction upon F:	NONE (OFF1, OFF2, OFF3)
Acknowledge upon F:	IMMEDIATELY
Reaction upon N:	NONE
Acknowledge upon N:	NONE

---

<b>A07566 (F, N)</b>	<b>Drive: Encoder error in PROFIdrive encoder interface 2</b>
<b>Reaction:</b>	NONE
<b>Acknowledge:</b>	NONE
<b>Cause:</b>	An encoder error was signaled for encoder 2 via the PROFIdrive encoder interface (G2_ZSW.15). Alarm value (r2124, decimal): Error code from G2_XIST2, refer to the description regarding r0483.
<b>Remedy:</b>	Acknowledge the encoder error using the encoder control word (G2_STW.15 = 1).
Reaction upon F:	NONE (OFF1, OFF2, OFF3)
Acknowledge upon F:	IMMEDIATELY
Reaction upon N:	NONE
Acknowledge upon N:	NONE

<b>A07567 (F, N)</b>	<b>Drive: Encoder error in PROFIdrive encoder interface 32</b>
<b>Reaction:</b>	NONE
<b>Acknowledge:</b>	NONE
<b>Cause:</b>	An encoder error was signaled for encoder 3 via the PROFIdrive encoder interface (G3_ZSW.15). Alarm value (r2124, decimal): Error code from G3_XIST2, refer to the description regarding r0483.
<b>Remedy:</b>	Acknowledge the encoder error using the encoder control word (G3_STW.15 = 1).
Reaction upon F:	NONE (OFF1, OFF2, OFF3)
Acknowledge upon F:	IMMEDIATELY
Reaction upon N:	NONE
Acknowledge upon N:	NONE
<b>F07575</b>	<b>Drive: Motor encoder not ready</b>
<b>Reaction:</b>	OFF2
<b>Acknowledge:</b>	IMMEDIATELY
<b>Cause:</b>	The motor encoder signals that it is not ready. - initialization of encoder 1 (motor encoder) was unsuccessful. - the function "parking encoder" is active (selected using the encoder control word G1_STW.14 = 1). - the Sensor Module is defective.
<b>Remedy:</b>	Evaluate other queued faults via encoder 1.
<b>A07576</b>	<b>Drive: Sensorless operation active due to a fault</b>
<b>Reaction:</b>	NONE
<b>Acknowledge:</b>	NONE
<b>Cause:</b>	Sensorless control is active due to a fault (refer to r1407.13). The required response when an encoder fault occurs is parameterized in p0491. See also: p0491 (Motor encoder fault response ENCODER)
<b>Remedy:</b>	
<b>A07580 (F, N)</b>	<b>Drive: No Sensor Module with matching component number</b>
<b>Reaction:</b>	NONE
<b>Acknowledge:</b>	NONE
<b>Cause:</b>	A Sensor Module with the component number specified in p0141 was not found. Alarm value (r2124, decimal): Encoder data set involved (index of p0141).
<b>Remedy:</b>	Correct p0141.
Reaction upon F:	OFF1 (DCBRAKE, NONE, OFF2, OFF3, STOP1, STOP2)
Acknowledge upon F:	IMMEDIATELY (POWER ON)
Reaction upon N:	NONE
Acknowledge upon N:	NONE
<b>F07800</b>	<b>Drive: No power unit present</b>
<b>Reaction:</b>	NONE
<b>Acknowledge:</b>	IMMEDIATELY
<b>Cause:</b>	The power unit parameters cannot be read or no parameters are stored in the power unit. This fault also occurs if an incorrect topology was selected in the commissioning software and this parameterization is then downloaded into the CU. See also: r0200 (Power unit, actual code number)
<b>Remedy:</b>	Connect the data line to power unit and restart the Control Unit (POWER ON). Drive:

<b>F07801</b>	<b>Drive: Motor overcurrent</b>
<b>Reaction:</b>	OFF2 (NONE, OFF1, OFF3)
<b>Acknowledge:</b>	IMMEDIATELY
<b>Cause:</b>	The permissible motor limit current was exceeded. <ul style="list-style-type: none"> <li>- effective current limit set too low.</li> <li>- current controller not correctly set.</li> <li>- motor was braked with an excessively high stall torque correction factor.</li> <li>- U/f operation: Up ramp was set too short or the load is too high.</li> <li>- U/f operation: Short-circuit in the motor cable or ground fault.</li> <li>- U/f operation: Motor current does not match the current of Motor Module.</li> </ul> Note: Synchronous motor: Limit current= 1.3 * p0323 Induction motor: Limit current= 1.3 * r0209
<b>Remedy:</b>	<ul style="list-style-type: none"> <li>- check the current limits (p0323, p0640).</li> <li>- check the current controller (p1715, p1717).</li> <li>- reduce the stall torque correction factor (p0326).</li> <li>- increase the up ramp (p1318) or reduce the load.</li> <li>- check the motor and motor cables for short-circuit and ground fault.</li> <li>- check the Motor Module and motor combination.</li> </ul>
<b>F07802</b>	<b>Drive: Infeed or power unit not ready</b>
<b>Reaction:</b>	OFF2 (NONE)
<b>Acknowledge:</b>	IMMEDIATELY
<b>Cause:</b>	After an internal power-on command, the infeed or drive does not signal ready. <ul style="list-style-type: none"> <li>- monitoring time is too short.</li> <li>- DC link voltage is not present.</li> <li>- associated infeed or drive of the signaling component is defective.</li> <li>- supply voltage incorrectly set.</li> </ul>
<b>Remedy:</b>	<ul style="list-style-type: none"> <li>- increase the monitoring time (p0857).</li> <li>- ensure that there is a DC link voltage. Check the DC-link busbar. Enable the infeed.</li> <li>- replace the associated infeed or drive of the signaling component.</li> <li>- check the line supply voltage setting (p0210).</li> </ul> See also: p0857 (Power unit monitoring time)
<b>A07805 (N)</b>	<b>Drive: Power unit I2T overload</b>
<b>Reaction:</b>	NONE
<b>Acknowledge:</b>	NONE
<b>Cause:</b>	Alarm threshold for I2t overload (p0294) of the power unit exceeded. The response parameterized in p0290 becomes active. See also: p0290 (Power unit overload response)
<b>Remedy:</b>	<ul style="list-style-type: none"> <li>- reduce the continuous load.</li> <li>- adapt the load duty cycle.</li> <li>- check the assignment of the rated currents of the motor and Motor Module.</li> </ul>
Reaction upon N:	NONE
Acknowledge upon N:	NONE
<b>F07810</b>	<b>Drive: Power unit EEPROM without rated data</b>
<b>Reaction:</b>	NONE
<b>Acknowledge:</b>	IMMEDIATELY
<b>Cause:</b>	No rated data are stored in the power unit EEPROM. See also: p0205 (Power unit application), r0206 (Rated power unit power), r0207 (Rated power unit current), r0208 (Rated power unit line supply voltage), r0209 (Power unit, maximum current)
<b>Remedy:</b>	Replace the power unit or inform Siemens Customer Service.

<b>F07815</b>	<b>Drive: Power unit has been changed</b>
<b>Reaction:</b>	NONE
<b>Acknowledge:</b>	IMMEDIATELY
<b>Cause:</b>	The code number of the actual power unit does not match the saved number. Fault value (r0949, decimal): Number of the incorrect parameter. See also: r0200 (Power unit, actual code number), p0201 (Power unit code number)
<b>Remedy:</b>	Connect the original power unit and power-up the Control Unit again (POWER ON) or set p0201 to r0200 and exit commissioning with p0010 = 0. For infeeds, the following applies: Commutating reactors or line filters must be used that are clearly specified for the new power unit. A line supply and DC link identification routine (p3410 = 5) must then be carried-out. It is not possible to change the power unit without re-commissioning the system if the type of infeed (A_Infeed, B_Infeed, S_Infeed), the type of construction/design (Booksize, Chassis) or the voltage class differ between the old and new power units. For inverters, the following applies: If the new power unit is accepted, then if required, the current limit p0640 can be reduced by a lower maximum current of the power unit (r0209) (torque limits stay the same). If not only the power unit is changed, but also the motor, then the motor must be re-commissioning (e.g. using p0010 = 1). This is also necessary if motor data is still to be downloaded via DRIVE-CLiQ. See also: r0200 (Power unit, actual code number)
<b>A07820</b>	<b>Drive: Temperature sensor not connected</b>
<b>Reaction:</b>	NONE
<b>Acknowledge:</b>	NONE
<b>Cause:</b>	The temperature sensor for motor temperature monitoring, specified in p0600, is not available. - parameter download with "incorrect" setting. - module with sensor evaluation has been, in the meantime, been removed.
<b>Remedy:</b>	- connect the module with temperature sensor. - set the available temperature sensor (p0600, p0601). See also: p0600 (Motor temperature sensor for monitoring), p0601 (Motor temperature sensor type)
<b>A07825 (N)</b>	<b>Drive: Simulation operation activated</b>
<b>Reaction:</b>	NONE
<b>Acknowledge:</b>	NONE
<b>Cause:</b>	The simulation mode is activated. The drive can only be powered-up if the DC link voltage is less than 40 V.
<b>Remedy:</b>	The alarm automatically disappears if simulation operation is de-activated with p1272 = 0.
Reaction upon N:	NONE
Acknowledge upon N:	NONE
<b>F07826</b>	<b>Drive: Simulation operation with DC link voltage too high</b>
<b>Reaction:</b>	OFF2
<b>Acknowledge:</b>	IMMEDIATELY
<b>Cause:</b>	The simulation mode is activated and the DC link voltage is greater than the permissible value of 40 V.
<b>Remedy:</b>	- switch-out (disable) simulation operation (p1272 = 0) and acknowledge the fault. - reduce the input voltage in order to reach a DC link voltage below 40 V.
<b>F07840</b>	<b>Drive: Infeed operation missing</b>
<b>Reaction:</b>	OFF2 (NONE)
<b>Acknowledge:</b>	IMMEDIATELY
<b>Cause:</b>	The signal "infeed operation" is not present although the enable signals for the drive have been present for longer than the parameterized monitoring time (p0857). - infeed not operational. - interconnection of the binector input for the ready signal is either incorrect or missing (p0864). - infeed is presently carrying-out a line supply identification routine.

**Remedy:**

- bring the infeed into an operational state.
- check the interconnection of the binector input for the signal "infeed operation" (p0864).
- increase the monitoring time (p0857).
- wait until the infeed has completed the line supply identification routine.

See also: p0857 (Power unit monitoring time), p0864 (Infeed operation)

**F07841 Drive: Infeed operation withdrawn**

**Reaction:** OFF2 (NONE, OFF1, OFF3)

**Acknowledge:** IMMEDIATELY

**Cause:**

The signal "infeed operation" was withdrawn in operation.

- interconnection of the binector input for the signal "infeed operation" is either incorrect or missing (p0864).
- the enable signals of the infeed were disabled.
- due to a fault, the infeed withdraws the signal "infeed operation".

**Remedy:**

- check the interconnection of the binector input for the signal "infeed operation" (p0864).
- check the enable signals of the infeed and if required, enable.
- remove and acknowledge an infeed fault.

Note:

If this drive is intended to back-up the DC link regeneratively, then the fault response must be parameterized for NONE so that the drive can continue to operate even after the infeed fails.

**A07850 (F) External alarm 1**

**Reaction:** NONE

**Acknowledge:** NONE

**Cause:**

The BICO signal for "external alarm 1" was triggered.  
 The condition for this external alarm is fulfilled.  
 See also: p2112 (External alarm 1)

**Remedy:** Eliminate the causes of this alarm.

Reaction upon F: A\_INFEED: NONE (OFF1, OFF2)  
 SERVO: NONE (DCBRAKE, OFF1, OFF2, OFF3, STOP1, STOP2)  
 VECTOR: NONE (DCBRAKE, OFF1, OFF2, OFF3, STOP1, STOP2)

Acknowledge upon F: IMMEDIATELY (POWER ON)

**A07851 (F) External alarm 2**

**Reaction:** NONE

**Acknowledge:** NONE

**Cause:**

The BICO signal for "external alarm 2" was triggered.  
 The condition for this external alarm is fulfilled.  
 See also: p2116 (External alarm 2)

**Remedy:** Eliminate the causes of this alarm.

Reaction upon F: A\_INFEED: NONE (OFF1, OFF2)  
 SERVO: NONE (DCBRAKE, OFF1, OFF2, OFF3, STOP1, STOP2)  
 VECTOR: NONE (DCBRAKE, OFF1, OFF2, OFF3, STOP1, STOP2)

Acknowledge upon F: IMMEDIATELY (POWER ON)

**A07852 (F) External alarm 3**

**Reaction:** NONE

**Acknowledge:** NONE

**Cause:**

The BICO signal for "external alarm 3" was triggered.  
 The condition for this external alarm is fulfilled.  
 See also: p2117 (External alarm 3)

**Remedy:** Eliminate the causes of this alarm.

Reaction upon F: A\_INFEED: NONE (OFF1, OFF2)  
 SERVO: NONE (DCBRAKE, OFF1, OFF2, OFF3, STOP1, STOP2)  
 VECTOR: NONE (DCBRAKE, OFF1, OFF2, OFF3, STOP1, STOP2)

Acknowledge upon F: IMMEDIATELY (POWER ON)

<b>F07860 (A)</b>	<b>External fault 1</b>
<b>Reaction:</b>	A_INFEED: OFF2 (NONE, OFF1) SERVO: OFF2 (DCBRAKE, NONE, OFF1, OFF3, STOP1, STOP2) VECTOR: OFF2 (DCBRAKE, NONE, OFF1, OFF3, STOP1, STOP2)
<b>Acknowledge:</b>	IMMEDIATELY (POWER ON)
<b>Cause:</b>	The BICO signal "external fault 1" was triggered. See also: p2106 (External fault 1)
<b>Remedy:</b>	Eliminate the causes of this fault.
Reaction upon A:	NONE
Acknowledge upon A:	NONE
<b>F07861 (A)</b>	<b>External fault 2</b>
<b>Reaction:</b>	A_INFEED: OFF2 (NONE, OFF1) SERVO: OFF2 (DCBRAKE, NONE, OFF1, OFF3, STOP1, STOP2) VECTOR: OFF2 (DCBRAKE, NONE, OFF1, OFF3, STOP1, STOP2)
<b>Acknowledge:</b>	IMMEDIATELY (POWER ON)
<b>Cause:</b>	The BICO signal "external fault 2" was triggered. See also: p2107 (External fault 2)
<b>Remedy:</b>	Eliminate the causes of this fault.
Reaction upon A:	NONE
Acknowledge upon A:	NONE
<b>F07862 (A)</b>	<b>External fault 3</b>
<b>Reaction:</b>	A_INFEED: OFF2 (NONE, OFF1) SERVO: OFF2 (DCBRAKE, NONE, OFF1, OFF3, STOP1, STOP2) VECTOR: OFF2 (DCBRAKE, NONE, OFF1, OFF3, STOP1, STOP2)
<b>Acknowledge:</b>	IMMEDIATELY (POWER ON)
<b>Cause:</b>	The BICO signal "external fault 3" was triggered. See also: p2108 (External fault 3), p3111 (External fault 3, enable), p3112 (External fault 3 enable negated)
<b>Remedy:</b>	Eliminate the causes of this fault.
Reaction upon A:	NONE
Acknowledge upon A:	NONE
<b>F07900 (N, A)</b>	<b>Drive: Motor locked/speed controller at its limit</b>
<b>Reaction:</b>	OFF2 (NONE, OFF1, OFF3, STOP1, STOP2)
<b>Acknowledge:</b>	IMMEDIATELY
<b>Cause:</b>	Motor has been operating at the torque limit longer than the time specified in p2177 and below the speed threshold set in p2175. This signal can also be initiated if the speed actual value is oscillating and the speed controller output repeatedly goes to its limit. See also: p2175 (Motor locked speed threshold), p2177 (Motor locked delay time)
<b>Remedy:</b>	<ul style="list-style-type: none"> <li>- check that the motor can freely rotate.</li> <li>- check the torque limit: For a positive direction of rotation r1538, for a negative direction of rotation r1539.</li> <li>- check the parameter, message "Motor locked" and if required, correct (p2175, p2177).</li> <li>- check the inversion of the actual value (p0410).</li> <li>- check the motor encoder connection.</li> <li>- check the encoder pulse number (p0408).</li> <li>- for SERVO with sensorless operation and motors with low power ratings (&lt; 300 W), increase the pulse frequency (p1800).</li> </ul>
Reaction upon N:	NONE
Acknowledge upon N:	NONE

Reaction upon A: NONE  
 Acknowledge upon A: NONE

---

**F07901 Drive: Motor overspeed**

**Reaction:** OFF2 (OFF1)  
**Acknowledge:** IMMEDIATELY  
**Cause:** The maximum permissible speed was either positively or negatively exceeded.  
 The maximum permissible positive speed is formed as follows: Minimum(p1082, Cl: p1085) + p2162. The maximum permissible negative speed is formed as follows: Maximum(-p1082, Cl: 1088) - p2162.  
**Remedy:** For a positive direction of rotation:  
 - check r1084 and if required, correct p1082, Cl:p1085 and p2162.  
 For a negative direction of rotation:  
 - check r1087 and if required, correct p1082, Cl:p1088 and p2162.

---

**F07902 (N, A) Drive: Motor stalled**

**Reaction:** OFF2 (NONE, OFF1, OFF3, STOP1, STOP2)  
**Acknowledge:** IMMEDIATELY  
**Cause:** For a vector drive the system has identified that the motor has stall for a time longer than is set in p2178.  
 Fault value (r0949, decimal):  
 1: Stall detection using r1408.11 (p1744).  
 2: Stall detection using r1408.12 (p1745).  
 3: Stall detection using r0056.11 (only for separately excited synchronous motors).  
 See also: p1744 (Motor model speed threshold stall detection), p2178 (Motor stalled delay time)  
**Remedy:** For closed-loop speed and torque control with speed encoder, the following applies:  
 - check the speed signal (interrupted cable, polarity, pulse number).  
 If there is no fault, then the fault tolerance can be increased (p1744).  
 For closed-loop speed and torque control without speed encoder, the following applies:  
 - check whether the drive stalls due to the load if the speed setpoint is still zero. If yes, then increase the current setpoint using p1610.  
 - if the motor excitation (magnetizing) time (r0346) was significantly reduced, then it should be increased again.  
 - check the current limits (p0640, r0067). If these are too low, then the drive cannot be magnetized.  
 - check the current controller (p1715, p1717) and the speed adaptation controller (p1764, p1767). If the dynamic response was significantly reduced, then this should be increased again.  
 If there is no fault, then the fault tolerance (p1745) or the delay time (p2178) can be increased.  
 For separately-excited synchronous motors (closed-loop control with speed encoder), the following applies:  
 - check the speed signal (interrupted cable, polarity, pulse number).  
 - ensure the correct motor parameterization (rating plate and equivalent circuit diagram parameters).  
 - check the excitation equipment and the interface to the closed-loop control.  
 - encoder the highest possible dynamic response of the closed-loop excitation current control.  
 - check the speed control for any tendency to oscillate and if resonance effects occur, use a bandstop filter.  
 - do not exceed the maximum speed (p2162).  
 If there is no fault, then the delay time can be increased (p2178).

Reaction upon N: NONE  
 Acknowledge upon N: NONE  
 Reaction upon A: NONE  
 Acknowledge upon A: NONE

**A07903 Drive: Motor speed deviation**

**Reaction:** NONE

**Acknowledge:** NONE

**Cause:** The absolute value of the speed difference from the two setpoints (p2151, p2154) and the speed actual value (r2169) exceeds the tolerance threshold (p2163) longer than tolerated (p2164, p2166).  
The alarm is only enabled for p2149.0 = 1.  
Possible causes could be:

- the load torque is greater than the torque setpoint.
- when accelerating, the torque/current/power limit is reached. If the limits are not sufficient, then it is possible that the drive has been dimensioned too small.
- the speed controller is inhibited (refer to p0856; refer to Kp/Tn adaptation of the speed controller).
- for closed-loop torque control, the speed setpoint does not track the speed actual value.
- for active Vdc controller.
- the encoder pulse number was incorrectly parameterized (p0408).

The signal is not generated if the ramp-function generator tracking prevents the setpoint and actual speed from drifting (moving) apart.  
Only for vector drives:  
For U/f control, the overload condition is detected as the I<sub>max</sub> controller is active.  
See also: p2149 (Monitoring, configuration)

**Remedy:**

- increase p2163 and/or p2166.
- increase the torque/current/power limits.
- enable the speed controller.
- for closed-loop torque control: The speed setpoint should track the speed actual value.
- correct the encoder pulse number in p0408 or mount the correct tachometer.

**A07904 (N) External armature short-circuit: Contactor feedback signal "closed" missing**

**Reaction:** NONE

**Acknowledge:** NONE

**Cause:** When closing, the contactor feedback signal (p1235) did not issue the signal "closed" (r1239.1 = 1) within the monitoring time (p1236).

**Remedy:**

- check that the contactor feedback signal is correctly connected (p1235).
- check the logic of the contactor feedback signal (r1239.1 = 1: "closed", r1239.1 = 0: "open").
- increase the monitoring time (p1236).
- if required, set the external armature short-circuit without contactor feedback signal (p1231=2).

Reaction upon N: NONE  
Acknowledge upon N: NONE

**F07905 (N, A) External armature short-circuit: Contactor feedback signal "open" missing**

**Reaction:** OFF2 (NONE)

**Acknowledge:** IMMEDIATELY

**Cause:** When opening, the contactor feedback signal (p1235) did not issue the signal "open" (r1239.1 = 0) within the monitoring time (p1236).

**Remedy:**

- check that the contactor feedback signal is correctly connected (p1235).
- check the logic of the contactor feedback signal (r1239.1 = 1: "closed", r1239.1 = 0: "open").
- increase the monitoring time (p1236).
- if required, set the external armature short-circuit without contactor feedback signal (p1231=2).

Reaction upon N: NONE  
Acknowledge upon N: NONE  
Reaction upon A: NONE  
Acknowledge upon A: NONE



<b>F07906</b>	<b>Armature short-circuit: Parameterization error</b>
<b>Reaction:</b>	OFF2
<b>Acknowledge:</b>	IMMEDIATELY
<b>Cause:</b>	<p>The armature short-circuit is incorrectly parameterized.</p> <p>Fault value (r0949, decimal):</p> <p>Low word: Motor data set number</p> <p>High word: Cause:</p> <p>1: A permanent-magnet synchronous motor has not been selected.</p> <p>101: External armature short-circuit: Output (r1239.0) not connected-up.</p> <p>102: External armature short-circuit with contactor feedback signal: no feedback signal connected (BI:p1235)</p> <p>103: External armature short-circuit without contactor feedback signal: Delay time when opening (p1237) is 0.</p> <p>201: Internal voltage protection: The maximum output current of the motor module (r0289) is less than 1.8* of the motor short-circuit current (r0331).</p> <p>202: Internal voltage protection: A booksize motor module is not being used.</p> <p>203: Internal voltage protection: The motor short-circuit current (p0320) is greater than the maximum motor current (p0323).</p>
<b>Remedy:</b>	<p>Re cause 1:</p> <ul style="list-style-type: none"> <li>- an armature short-circuit is only permissible for permanent-magnetic synchronous motors. The highest position of the motor type in p0300 must either be 2 or 4.</li> </ul> <p>Re cause 101:</p> <ul style="list-style-type: none"> <li>- the contactor for the external armature short-circuit configuration should be controlled using output signal r1239.0. The signal can, e.g. be connected to an output terminal BI: p0738. Before this fault can be acknowledged, parameter p1231 must be set again.</li> </ul> <p>Re cause 102:</p> <ul style="list-style-type: none"> <li>- if the external armature short-circuit with contactor feedback signal (p1231=1) is selected, this feedback signal must be connected to an input terminal (e.g. r722.x) and then connected to BI:p1235.</li> <li>- alternatively, the external armature short-circuit without contactor feedback signal (p1231=2) can be selected.</li> </ul> <p>Re cause 103:</p> <ul style="list-style-type: none"> <li>- if the external armature short-circuit without contactor feedback signal (p1231=2) is selected, then a delay time must be parameterized in p1237. This time must always be greater than the actual contactor opening time, as otherwise the motor module would be short-circuited!</li> </ul> <p>Re cause 201:</p> <ul style="list-style-type: none"> <li>- a Motor Module with a higher maximum current or a motor with a lower short-circuit current must be used. The maximum Motor Module current must be 1.8 * higher than the short-circuit current of the motor.</li> </ul> <p>Re cause 202:</p> <ul style="list-style-type: none"> <li>- a Booksize Motor Module must be used for the internal voltage protection.</li> </ul> <p>Re cause 203:</p> <ul style="list-style-type: none"> <li>- for internal voltage protection, only short-circuit proof motors may be used.</li> </ul>
<b>F07907</b>	<b>Internal voltage protection: Motor terminals are not at zero potential after pulse cancellation</b>
<b>Reaction:</b>	NONE
<b>Acknowledge:</b>	IMMEDIATELY
<b>Cause:</b>	<ul style="list-style-type: none"> <li>- when the internal voltage protection is active (p1231 = 3), after pulse cancellation, all of the motor terminals are at half of the DC link voltage (without an internal voltage protection, the motor terminals are at zero potential)!</li> <li>- in order to ensure safe function of IVP when the power fails, an external 24 V power supply (UPS) must be used for all of the components.</li> </ul>
<b>Remedy:</b>	<p>None necessary.</p> <p>This a note for the user.</p>

<b>A07910 (N)</b>	<b>Drive: Motor overtemperature</b>
<b>Reaction:</b>	NONE
<b>Acknowledge:</b>	NONE
<b>Cause:</b>	<p>KTY: The motor temperature has exceeded the alarm threshold (p0604). VECTOR: The response parameterized in p0610 becomes active.</p> <p>PTC: The response threshold of 1650 Ohm was exceeded. Alarm value (r2124, decimal): SME not selected in p0601: 1: No output current reduction. 1: Output current reduction active. SME selected in p0601 (p0601=10) The number specifies the sensor channel that resulted in the alarm being output. See also: p0604 (Motor overtemperature alarm threshold), p0610 (Response to motor overtemperature condition)</p>
<b>Remedy:</b>	<ul style="list-style-type: none"> <li>- check the motor load.</li> <li>- check the motor ambient temperature.</li> </ul>
Reaction upon N:	NONE
Acknowledge upon N:	NONE
<b>F07913</b>	<b>Excitation current outside the tolerance range</b>
<b>Reaction:</b>	OFF2
<b>Acknowledge:</b>	IMMEDIATELY
<b>Cause:</b>	<p>The difference between the excitation current actual value and setpoint has exceeded the tolerance: <math>\text{abs}(r1641 - r1626) &gt; p3201 + p3202</math> The cause of this fault is again reset for <math>\text{abs}(r1641 - r1626) &lt; p3201</math>.</p>
<b>Remedy:</b>	<ul style="list-style-type: none"> <li>- check the parameterization (p1640, p3201, p3202).</li> <li>- check the interfaces to the excitation equipment (r1626, p1640).</li> <li>- check the excitation equipment.</li> </ul>
<b>F07914</b>	<b>Flux out of tolerance</b>
<b>Reaction:</b>	OFF2
<b>Acknowledge:</b>	IMMEDIATELY
<b>Cause:</b>	<p>The difference between the flux actual value and setpoint has exceeded the tolerance: <math>\text{abs}(r0084 - r1598) &gt; p3204 + p3205</math> The cause of this fault is again reset for <math>\text{abs}(r0084 - r1598) &lt; p3204</math>.</p>
<b>Remedy:</b>	<ul style="list-style-type: none"> <li>- check the parameterization (p3204, p3205).</li> <li>- check the interfaces to the excitation equipment (r1626, p1640).</li> <li>- check the excitation equipment.</li> <li>- check the flux control (p1592, p1592, p1597).</li> <li>- check the control for oscillation and take the appropriate counter measures (e.g. optimize the speed control loop, parameterize a bandstop filter).</li> </ul>
<b>A07918 (N)</b>	<b>Three-phase setpoint generator operation selected/active</b>
<b>Reaction:</b>	NONE
<b>Acknowledge:</b>	NONE
<b>Cause:</b>	<p>Only for separately excited synchronous motors (p0300 = 5): The actual open-loop/closed-loop control mode is I/f control (open-loop) with a fixed current (p1300 = 18). The speed is entered via the setpoint channel and the current setpoint is given by the minimum current (p1620). It must be ensured that in this mode, the control dynamic performance is very limited. This is the reason that longer ramp-up times should be set for the setpoint speed than for normal operation. See also: p1620 (Stator current, minimum)</p>
<b>Remedy:</b>	<p>Select another open-loop/closed-loop control mode See also: p1300 (Open-loop/closed-loop control operating mode)</p>
Reaction upon N:	NONE
Acknowledge upon N:	NONE

---

**A07920**      **Drive: Torque too low**  
**Reaction:**      NONE  
**Acknowledge:**      NONE  
**Cause:**      The torque deviates from the torque/speed envelope characteristic in the negative direction (too low).  
                     See also: p2181 (Load monitoring, response)  
**Remedy:**      Adapt the load.

---

**A07921**      **Drive: Torque too high**  
**Reaction:**      NONE  
**Acknowledge:**      NONE  
**Cause:**      The torque deviates from the torque/speed envelope characteristic in the positive direction (too high).  
**Remedy:**      Adapt the load.

---

**A07922**      **Drive: Torque outside the tolerance**  
**Reaction:**      NONE  
**Acknowledge:**      NONE  
**Cause:**      The torque deviates from the torque/speed envelope characteristic.  
**Remedy:**      Adapt the load.

---

**F07923**      **Drive: Torque too low**  
**Reaction:**      OFF1 (NONE, OFF2, OFF3)  
**Acknowledge:**      IMMEDIATELY  
**Cause:**      The torque deviates from the torque/speed envelope characteristic in the negative direction (too low).  
**Remedy:**      Adapt the load.

---

**F07924**      **Drive: Torque too high**  
**Reaction:**      OFF1 (NONE, OFF2, OFF3)  
**Acknowledge:**      IMMEDIATELY  
**Cause:**      The torque deviates from the torque/speed envelope characteristic in the positive direction (too high).  
**Remedy:**      Adapt the load.

---

**F07925**      **Drive: Torque outside the tolerance**  
**Reaction:**      OFF1 (NONE, OFF2, OFF3)  
**Acknowledge:**      IMMEDIATELY  
**Cause:**      The torque deviates from the torque/speed envelope characteristic.  
**Remedy:**      Adapt the load.

---

**A07926**      **Drive: Envelope curve, parameter invalid**  
**Reaction:**      NONE  
**Acknowledge:**      NONE  
**Cause:**      Invalid parameter values were entered for the envelope characteristic of the load monitoring.  
                     The following rules apply for the speed thresholds:  
                     p2182 < p2183 < p2184  
                     The following rules apply for the torque thresholds:  
                     p2185 > p2186  
                     p2187 > p2188  
                     p2189 > p2190  
                     Alarm value (r2124, decimal):  
                     Number of the parameter with the invalid value.  
**Remedy:**      Set the parameters for the load monitoring according to the applicable rules.

<b>F07930</b>	<b>Drive: Braking signal error</b>
<b>Reaction:</b>	OFF1 (NONE, OFF2, OFF3)
<b>Acknowledge:</b>	IMMEDIATELY
<b>Cause:</b>	<p>The Control Unit has detected a braking signal error.</p> <ul style="list-style-type: none"> <li>- no motor holding brake connected.</li> <li>- motor holding brake type incorrectly parameterized.</li> <li>- the motor holding brake control on the Motor Module is faulty.</li> <li>- a DRIVE-CLiQ communications error has occurred between the Control Unit and the Motor Module involved.</li> </ul> <p>Fault value (r0949, decimal):</p> <p>10: No brake connected or fault in the Motor Module brake control circuit ("open brake" operation).            11: Defect in the brake control circuit of the Motor Module ("brake open" operation).            20: Short-circuit in the brake winding or fault in the brake control circuit of the Motor Module ("brake open" state).            30: No brake connected, short-circuit in the brake winding or fault in the Motor Module brake control circuit ("close brake" operation).            31: Defect in the brake control circuit of the Motor Module ("close brake" operation).            40: Defect in the brake control circuit of the Motor Module ("brake closed" state).            50: Defect in the brake control circuit of the Motor Module or communications fault between the Control Unit and the Motor Module (braking signal diagnostics).</p> <p>See also: p1278 (Motor holding brake type)</p>
<b>Remedy:</b>	<ul style="list-style-type: none"> <li>- check the motor holding brake connection.</li> <li>- check the motor holding brake type.</li> <li>- check the function of the motor holding brake.</li> <li>- check whether there is a DRIVE-CLiQ communications error between the Control Unit and the Motor Module involved and if required, carry-out a diagnostics routine for the faults identified.</li> <li>- check the electrical cabinet design and cable routing for EMC compliance</li> <li>- replace the Motor Module involved.</li> <li>- if a motor holding brake has still not been connected, then the brake control can be disabled with p1215 = 0 in order to suppress the fault (e.g. for a rotating measurement (p1960)).</li> </ul> <p>Operation with Safe Brake Module:</p> <ul style="list-style-type: none"> <li>- check the Safe Brake Modules connection.</li> <li>- replace the Safe Brake Module.</li> </ul>
<b>A07931</b>	<b>Brake does not open</b>
<b>Reaction:</b>	NONE
<b>Acknowledge:</b>	NONE
<b>Cause:</b>	<p>This alarm is output for r1229.4 = 1.</p> <p>See also: p1216 (Motor holding brake, opening time), r1229 (Motor holding brake status word)</p>
<b>Remedy:</b>	<ul style="list-style-type: none"> <li>- check the functionality of the motor holding brake.</li> <li>- check the feedback signal (p1223).</li> </ul>
<b>A07932</b>	<b>Brake does not close</b>
<b>Reaction:</b>	NONE
<b>Acknowledge:</b>	NONE
<b>Cause:</b>	<p>This alarm is output for r1229.5 = 1.</p> <p>See also: p1217 (Motor holding brake closing time), r1229 (Motor holding brake status word)</p>
<b>Remedy:</b>	<ul style="list-style-type: none"> <li>- check the functionality of the motor holding brake.</li> <li>- check the feedback signal (p1222).</li> </ul>
<b>F07935 (N)</b>	<b>Drv: Motor holding brake detected</b>
<b>Reaction:</b>	NONE (OFF1, OFF2, OFF3)
<b>Acknowledge:</b>	IMMEDIATELY
<b>Cause:</b>	<p>A motor with integrated motor holding brake was detected where the braking signal has not been configured (p1215 = 0). The braking signal configuration was then set to "motor holding brake the same as sequence control" (p1215 = 1).</p>
<b>Remedy:</b>	<p>None necessary.</p> <p>See also: p1215 (Motor holding brake configuration)</p>
Reaction upon N:	NONE
Acknowledge upon N:	NONE

<b>F07940</b>	<b>Sync-line supply - drive: Synchronization error</b>
<b>Reaction:</b>	OFF2
<b>Acknowledge:</b>	IMMEDIATELY
<b>Cause:</b>	After synchronization has been completed, the phase difference (r3808) is greater than the threshold value, phase synchronism (p3813). OFF1 or OFF3 response, while the closed-loop phase control is active (r3819.6 = 1) or synchronism reached (r3819.2 = 1). Enable signal withdrawn (p3802 = 0), while the closed-loop phase control was active (r3819.6 = 1).
<b>Remedy:</b>	If required increase the threshold value phase synchronism (p3813) for synchronizing the line supply to the drive. Before OFF1 or OFF3, complete synchronizing (r03819.0 = 0). Before withdrawing the enable signal (p3802 = 0), reach synchronism (r3819.2 = 1). See also: p3813 (Sync line-drive phase synchronism threshold value)
<b>A07941</b>	<b>Sync-line supply - drive: Target frequency not permissible</b>
<b>Reaction:</b>	NONE
<b>Acknowledge:</b>	NONE
<b>Cause:</b>	The target frequency is outside the permissible value range. Alarm value (r2124, decimal): 1084: Target frequency greater than the positive speed limit, $f_{sync} > f_{max}$ (r1084). 1087: Target frequency less than the negative speed limit, $f_{sync} < f_{min}$ (r1087).
<b>Remedy:</b>	Fulfill the target frequency conditions for the synchronization line supply - drive. See also: r1084 (Speed limit positive effective), r1087 (Speed limit negative effective)
<b>A07942</b>	<b>Sync-line supply - drive: Setpoint frequency is completely different than the target frequency</b>
<b>Reaction:</b>	NONE
<b>Acknowledge:</b>	NONE
<b>Cause:</b>	There is a considerable difference between the setpoint frequency and the target frequency ( $f_{set} \ll f_{target}$ ). The deviation that can be tolerated is set in p3806.
<b>Remedy:</b>	The alarm automatically disappears after the difference that can be tolerated (p3806) between the setpoint and target frequencies is reached. See also: p3806 (Sync line-drive frequency difference threshold value)
<b>A07943</b>	<b>Sync-line supply - drive: Synchronization not permitted</b>
<b>Reaction:</b>	NONE
<b>Acknowledge:</b>	NONE
<b>Cause:</b>	Synchronization not permitted. Alarm value (r2124, decimal): 1300: The control mode (p1300) has not been set to sensorless closed-loop speed control or U/f characteristic. 1910: Motor data identification activated. 1960: Speed controller optimization activated. 1990: Encoder adjustment activated. 3801: Voltage Sensing Module (VSM) not found. 3845: Friction characteristic plot activated.
<b>Remedy:</b>	Fulfill the conditions for the synchronization line supply - drive. Re alarm value = 1300: Set the control mode (p1300) to sensorless closed-loop speed control (p1300 = 20) or U/f characteristic (p1300 = 0 ... 19). Re alarm value = 1910: Exit the motor data identification routine (p1910). Re alarm value = 1960: Exit the speed controller optimization routine (p1960). Re alarm value = 1990: Exit the encoder adjustment (p1990). Re alarm value = 3801: Connect-up a Voltage Sensing Module (VSM) and when connecting to an adjacent drive object ensure that the drive objects have the same basis clock cycle. Re alarm value = 3845: Exit the friction characteristic plot (p3845).

<b>F07950 (A)</b>	<b>Drive: Incorrect motor parameter</b>
<b>Reaction:</b>	NONE
<b>Acknowledge:</b>	IMMEDIATELY
<b>Cause:</b>	The motor parameters were incorrectly entered while commissioning (e.g. p0300 = 0, no motor selected) Fault value (r0949, decimal): The fault value includes the parameter number involved. The following parameter numbers only occur as fault values for induction motors: p0304, p0310, p0320 The following parameter numbers only occur as fault values for synchronous motors: p0314; only for vector drives: p0305, p0307; only for servo drives: p0316, p0322, p0323; only for linear drives: p0315 See also: p0300 (Mot type selection), p0301 (Motor code number selection), p0304 (Rated motor voltage), p0305 (Rated motor current), p0307 (Rated motor power), p0310 (Rated motor frequency), p0311 (Rated motor speed), p0314 (Motor pole pair number), p0315 (Motor pole pair width), p0316 (Motor torque constant), p0320 (Motor rated magnetization current/short-circuit current), p0322 (Maximum motor speed), p0323 (Maximum motor current)
<b>Remedy:</b>	Compare the motor data with the rating plate data and if required, correct. See also: p0300 (Mot type selection), p0301 (Motor code number selection), p0304 (Rated motor voltage), p0305 (Rated motor current), p0307 (Rated motor power), p0310 (Rated motor frequency), p0311 (Rated motor speed), p0314 (Motor pole pair number), p0316 (Motor torque constant), p0320 (Motor rated magnetization current/short-circuit current), p0322 (Maximum motor speed), p0323 (Maximum motor current)
Reaction upon A:	NONE
Acknowledge upon A:	NONE

<b>F07955</b>	<b>Drive: Motor has been changed</b>
<b>Reaction:</b>	NONE
<b>Acknowledge:</b>	IMMEDIATELY
<b>Cause:</b>	The code number of the actual motor with DRIVE-CLiQ does not match the saved number. Fault value (r0949, decimal): Number of the incorrect parameter. See also: p0301 (Motor code number selection), r0302 (Motor code number of motor with DRIVE-CLiQ)
<b>Remedy:</b>	Connect the original motor, power-up the Control Unit again (POWER ON) and exit the quick commissioning by setting p0010 to 0. Or set p0300 = 10000 (load the motor parameter with DRIVE-CLiQ) and re-commission. Quick commissioning (p0010 = 1) is automatically exited with p3900 > 0. If quick commissioning was exited by setting p0010 to 0, then an automatic controller calculation (p0340 = 1) is not carried-out.

<b>F07956</b>	<b>Drive: Motor code does not match the list (catalog) motor</b>
<b>Reaction:</b>	NONE
<b>Acknowledge:</b>	IMMEDIATELY
<b>Cause:</b>	The motor code of the actual motor with DRIVE-CLiQ does not match the possible list motor types (refer to the selection, p0300). Fault value (r0949, decimal): Motor code of the motor with DRIVE-CLiQ
<b>Remedy:</b>	Use a motor with DRIVE-CLiQ and the matching motor code. The first three digits of the motor code generally correspond to the matching list motor type.

<b>A07960</b>	<b>Drive: Incorrect friction characteristic</b>
<b>Reaction:</b>	NONE
<b>Acknowledge:</b>	NONE
<b>Cause:</b>	<p>The friction characteristic is incorrect.</p> <p>Alarm value (r2124, decimal): 1538: The friction torque is greater than the maximum from the upper effective torque limit (p1538) and zero. This is the reason that the output of the friction characteristic (r3841) is limited to this value.</p> <p>1539: The friction torque is less than the minimum from the lower effective torque limit (p1539) and zero. This is the reason that the output of the friction characteristic (r3841) is limited to this value.</p> <p>3820 ... 3829: Incorrect parameter number. The speeds entered in the parameters for the friction characteristic do not correspond to the following condition: <math>0.0 &lt; p3820 &lt; p3821 &lt; \dots &lt; p3829 \leq p0322</math> or <math>p1082</math>, if <math>p0322 = 0</math> Therefore the output of the friction characteristic (r3841) is set to zero.</p> <p>3830 ... 3839: Incorrect parameter number. The torques entered in the parameters for the friction characteristic do not correspond to the following condition: <math>0 \leq p3830, p3831 \dots p3839 \leq p0333</math> Therefore the output of the friction characteristic (r3841) is set to zero. See also: r3840 (Friction characteristic, status word)</p>
<b>Remedy:</b>	<p>Fulfill the conditions for the friction characteristic.</p> <p>Re alarm value = 1538: Check the upper effective torque limit (e.g. in the field weakening range).</p> <p>Re alarm value = 1539: Check the lower effective torque limit (e.g. in the field weakening range).</p> <p>Re alarm value = 3820 ... 3839: Fulfill the conditions to set the parameters of the friction characteristic. If the motor data (e.g. the maximum speed p0322) are changed during commissioning (p0010 = 1, 3), then the technological limits and threshold values, dependent on this, must be re-calculated by selecting p0340= 5).</p>
<b>A07961</b>	<b>Drive: Friction characteristic plot activated</b>
<b>Reaction:</b>	NONE
<b>Acknowledge:</b>	NONE
<b>Cause:</b>	<p>The automatic friction characteristic plot is activated.</p> <p>The friction characteristic is plotted at the next power-on command.</p>
<b>Remedy:</b>	<p>None necessary.</p> <p>The alarm disappears automatically after the friction characteristic plot has been successfully completed or the plot is de-activated (p3845 = 0).</p>

---

<b>F07963</b>	<b>Drive: Friction characteristic plot interrupted</b>
<b>Reaction:</b>	OFF1
<b>Acknowledge:</b>	IMMEDIATELY
<b>Cause:</b>	<p>The condition to plot the friction characteristic are not fulfilled.</p> <p>Fault value (r0949, decimal):</p> <p>0046: Missing enable signals (r0046).</p> <p>0840: OFF1 (p0840) is selected before the friction characteristic has been completely plotted.</p> <p>1082: The highest speed value to be approached (p3829) is greater than the maximum speed (p1082).</p> <p>1110: Friction characteristic plot, negative direction of rotation has be selected (p3845) and the negative direction of rotation is inhibited (p1110).</p> <p>1111: Friction characteristic plot, positive direction of rotation has be selected (p3845) and the positive direction of rotation is inhibited (p1111).</p> <p>1198: Friction characteristic plot selected (p3845 &gt; 0) and the negative direction of rotation (p1110) and positive (p1111) are inhibited (r1198).</p> <p>1300: The control mode (p1300) has not been set to closed-loop speed control.</p> <p>1755: For sensorless closed-loop control (p1300 = 20), the lowest speed value to be approached (p3820) is less than or equal to the changeover speed, open-loop controlled operation (p1755).</p> <p>1910: Motor data identification activated.</p> <p>1960: Speed controller optimization activated.</p> <p>3820 - 3829: Speed (p382x) cannot be approached.</p> <p>3840: Friction characteristic incorrect.</p> <p>3845: Friction characteristic plot de-selected.</p>
<b>Remedy:</b>	<p>Fulfill the conditions to plot the friction characteristic.</p> <p>Re fault value = 0046: Establish missing enable signals.</p> <p>Re fault value = 0840: Select OFF1 (p0840) only after the friction characteristic plot has been completed.</p> <p>Re fault value = 1082: Select the highest speed value to be approached (p3829) less than or equal to the maximum speed (p1082).</p> <p>Re fault value = 1110: Select the frequency characteristic plot, positive direction of rotation (p3845).</p> <p>Re fault value = 1111: Select the frequency characteristic plot, negative direction of rotation (p3845).</p> <p>Re fault value = 1198: Enable the permitted direction of rotation (p1110, p1111, r1198).</p> <p>Re fault value = 1300: Set the control mode (p1300) on the closed-loop speed control (p1300 = 20, 21).</p> <p>Re fault value = 1755: For sensorless closed-loop speed control (p1300 = 20) select the lowest speed value to be approached (p3820) greater than the changeover speed of open-loop controlled operation (p1755).</p> <p>Re fault value = 1910: Exit the motor data identification routine (p1910).</p> <p>Re fault value = 1960: Exist the speed controller optimization routine (p1960).</p> <p>Re fault value 3820 - 3829: - check the load at speed p382x. - check the speed signal (r0063) for oscillation at speed p382x. If required, check the speed controller settings.</p> <p>Re fault value = 3840: Make the friction characteristic error-free (p3820 - p3829, p3830 - p3839, p3840).</p> <p>Re fault value = 3845: Activate the friction characteristic plot (p3845).</p>

---

<b>F07966</b>	<b>Drive: Check the commutation angle</b>
<b>Reaction:</b>	OFF2 (NONE)
<b>Acknowledge:</b>	IMMEDIATELY
<b>Cause:</b>	The speed actual value was inverted and the associated angular commutation offset is not equal to zero and is therefore possibly incorrect.
<b>Remedy:</b>	Angular commutation offset after the actual value inversion or determine it again (p1990=1).



<b>F07967</b>	<b>Drive: Automatic encoder adjustment incorrect</b>
<b>Reaction:</b>	OFF2 (NONE, OFF1)
<b>Acknowledge:</b>	IMMEDIATELY
<b>Cause:</b>	A fault has occurred during the automatic encoder adjustment or the pole position identification. Only for internal Siemens troubleshooting.
<b>Remedy:</b>	Carry-out a POWER ON.
<b>F07968</b>	<b>Drive: Lq-Ld measurement incorrect</b>
<b>Reaction:</b>	OFF2
<b>Acknowledge:</b>	IMMEDIATELY
<b>Cause:</b>	A fault has occurred during the Lq-Ld measurement. Fault value (r0949, decimal): 10: Stage 1: The ratio between the measured current and zero current is too low. 12: Stage 1: The maximum current was exceeded. 15: Second harmonic too low. 16: Drive converter too small for the measuring technique. 17: Abort due to pulse inhibit.
<b>Remedy:</b>	Re fault value = 10: Check whether the motor is correctly connected. Replace the Motor Module involved. De-activate traversing (p1909). Re fault value = 12: Check whether motor data have been correctly entered. De-activate traversing (p1909). Re fault value = 16: De-activate traversing (p1909). Re fault value = 17: Repeat traversing.
<b>F07969</b>	<b>Drive: Incorrect pole position identification</b>
<b>Reaction:</b>	OFF2
<b>Acknowledge:</b>	IMMEDIATELY
<b>Cause:</b>	A fault has occurred during the pole position identification routine. Fault value (r0949, decimal): 1: Current controller limited 2: Motor shaft locked. 4: Encoder speed signal not plausible. 10: Stage 1: The ratio between the measured current and zero current is too low. 11: Stage 2: The ratio between the measured current and zero current is too low. 12: Stage 1: The maximum current was exceeded. 13: Stage 2: The maximum current was exceeded. 14: Current difference to determine the +d axis too low. 15: Second harmonic too low. 16: Drive converter too small for the measuring technique. 17: Abort due to pulse inhibit. 18: First harmonic too low. 20: Pole position identification requested with the motor shaft rotating and activated flying restart function.
<b>Remedy:</b>	Re fault value = 1: Check whether the motor is correctly connected. Check whether motor data have been correctly entered. Replace the Motor Module involved. Re fault value = 2: Open the motor holding brake (p1215) and bring the motor into a no-load condition. Re fault value = 4: Check whether the encoder pulse number (p0408) and gearbox factor (p0432, p0433) are correct. Check whether the motor pole pair number is correct (p0314). Re fault value = 10: When selecting p1980 = 4: Increase the value for p0325. When selecting p1980 = 1: Increase the value for p0329. Check whether the motor is correctly connected.

Replace the Motor Module involved.  
 Re fault value = 11:  
 Increase the value for p0329.  
 Check whether the motor is correctly connected.  
 Replace the Motor Module involved.  
 Re fault value = 12:  
 When selecting p1980 = 4: Reduce the value for p0325.  
 When selecting p1980 = 1: Reduce the value for p0329.  
 Check whether motor data have been correctly entered.  
 Re fault value = 13:  
 Reduce the value for p0329.  
 Check whether motor data have been correctly entered.  
 Re fault value = 14:  
 Increase the value for p0329.  
 Re fault value = 15:  
 Increase the value for p0325.  
 Motor not sufficiently anisotropic, change the technique (p1980==1 or 10).  
 Re fault value = 16:  
 De-activate traversing/moving (p1982).  
 Re fault value = 17:  
 Repeat traversing.  
 Re fault value 18:  
 Increase the value for p0329.  
 Saturation not sufficient, change the technique (p1980==10).  
 Re fault value = 20:  
 Before carrying-out a pole position identification routine ensure that the motor shaft is absolutely stationary (zero speed).

---

<b>F07970</b>	<b>Drive: Automatic encoder adjustment incorrect</b>
<b>Reaction:</b>	OFF2
<b>Acknowledge:</b>	IMMEDIATELY
<b>Cause:</b>	<p>A fault has occurred during the automatic encoder adjustment.                      Fault value (r0949, decimal):                      1: Current controller limited                      2: Motor shaft locked.                      4: Encoder speed signal not plausible.                      10: Stage 1: The ratio between the measured current and zero current is too low.                      11: Stage 2: The ratio between the measured current and zero current is too low.                      12: Stage 1: The maximum current was exceeded.                      13: Stage 2: The maximum current was exceeded.                      14: Current difference to determine the +d axis too low.                      15: Second harmonic too low.                      16: Drive converter too small for the measuring technique.                      17: Abort due to pulse inhibit.</p>
<b>Remedy:</b>	<p>Re fault value = 1:                      Check whether the motor is correctly connected.                      Check whether motor data have been correctly entered.                      Replace the Motor Module involved.                      Re fault value = 2:                      Open the motor holding brake (p1215) and bring the motor into a no-load condition.                      Re fault value = 4:                      Check whether the speed actual value inversion is correct (p0410.0).                      Check whether the motor is correctly connected.                      Check whether the encoder pulse number (p0408) and gearbox factor (p0432, p0433) are correct.                      Check whether the motor pole pair number is correct (p0314).                      Re fault value = 10:                      Increase the value for p0325.                      Check whether the motor is correctly connected.                      Replace the Motor Module involved.                      Re fault value = 11:                      Increase the value for p0329.                      Check whether the motor is correctly connected.</p>

Replace the Motor Module involved.  
 Re fault value = 12:  
 Reduce the value for p0325.  
 Check whether motor data have been correctly entered.  
 Re fault value = 13:  
 Reduce the value for p0329.  
 Check whether motor data have been correctly entered.  
 Re fault value = 14:  
 Increase the value for p0329.  
 Re fault value = 15:  
 Increase the value for p0325.  
 Re fault value = 16:  
 De-activate traversing/moving (p1982).  
 Re fault value = 17:  
 Repeat traversing.

---

**A07971 (N) Drive: Automatic encoder adjustment activated**

**Reaction:** NONE

**Acknowledge:** NONE

**Cause:** The automatic encoder adjustment is activated (p1990 = 1).  
 The automatic encoder adjustment is carried-out with the next power-on command.  
**SERVO:**  
 If a pole position identification technique is selected in p1980, and if p0301 does not contain a motor type with an encoder adjusted in the factory, p1990 is automatically activated if fault F07414 is output.  
 See also: p1990 (Angular commutation offset, commissioning support)

**Remedy:** None necessary.  
 The alarm automatically disappears after the encoder has been successfully adjusted or for the setting p1990 = 0.

Reaction upon N: NONE

Acknowledge upon N: NONE

---

**A07980 Drive: Rotating measurement activated**

**Reaction:** NONE

**Acknowledge:** NONE

**Cause:** The rotating measurement (automatic speed controller optimization) is activated.  
 The rotating measurement is carried-out at the next power-on command.  
 See also: p1960 (Rotating measurement selection)

**Remedy:** None necessary.  
 The alarm disappears automatically after the speed controller optimization has been successfully completed or for the setting p1900 = 0.

---

**A07981 Drive: Enable signals for the rotating measurement missing**

**Reaction:** NONE

**Acknowledge:** NONE

**Cause:** The rotating measurement cannot be started due to missing enable signals.

**Remedy:** - acknowledge faults that are present.  
 - establish missing enable signals.  
 See also: r0002 (Control Unit operating display), r0046 (Infeed missing enable signals)

---

**F07982 Drive: Rotating measurement encoder test**

**Reaction:** OFF1 (NONE, OFF2)

**Acknowledge:** IMMEDIATELY

**Cause:** A fault has occurred during the encoder test.  
 Fault value (r0949, decimal):  
 1: The speed did not reach a steady-state condition.  
 2: The speed setpoint was not able to be approached as the minimum limiting is active.  
 3: The speed setpoint was not able to be approached as the suppression (skip) bandwidth is active.  
 4: The speed setpoint was not able to be approached as the maximum limiting is active.  
 5: The encoder does not supply a signal.  
 6: Incorrect polarity.  
 7: Incorrect pulse number.  
 8: Encoder signal faults.  
 9: Voltage Sensing Module (VSM) incorrectly connected.

**Remedy:** Re fault value = 1:  
 - check the motor parameters.  
 - carry-out a motor data identification routine (p1910).  
 - if required, reduce the dynamic factor (p1967 < 25 %).  
 Re fault value = 2:  
 Adapt the speed setpoint (p1965) or minimum limiting (p1080).  
 Re fault value = 3:  
 Adapt the speed setpoint (p1965) or suppression (skip) bandwidths (p1091 ... p1094, p1101).  
 Re fault value = 4:  
 Adapt the speed setpoint (p1965) or maximum limiting (p1082, p1083 and p1086).  
 Re fault value = 5:  
 Check the encoder connection. If required, replace the encoder.  
 Re fault value = 6:  
 Check the connection assignment of the encoder cable. Adapt the polarity (p0410).  
 Re fault value = 7:  
 Adapt the pulse number (p0408).  
 Re fault value = 8:  
 Check the encoder connection and encoder cable. It is possible that there is a problem associated with the ground connection.  
 Re fault value = 9:  
 Check the connections of the Voltage Sensing Module (VSM).  
**Note:**  
 The encoder test can be switched-out (disabled) using p1959.0.  
 See also: p1959 (Rotating measurement configuration)

---

**F07983 Drive: Rotating measurement saturation characteristic**

**Reaction:** OFF1 (NONE, OFF2)

**Acknowledge:** IMMEDIATELY

**Cause:** A fault has occurred while determining the saturation characteristic.  
 Fault value (r0949, decimal):  
 1: The speed did not reach a steady-state condition.  
 2: The rotor flux did not reach a steady-state condition.  
 3: The adaptation circuit did not reach a steady-state condition.  
 4: The adaptation circuit was not enabled.  
 5: Field weakening active.  
 6: The speed setpoint was not able to be approached as the minimum limiting is active.  
 7: The speed setpoint was not able to be approached as the suppression (skip) bandwidth is active.  
 8: The speed setpoint was not able to be approached as the maximum limiting is active.  
 9: Several values of the determined saturation characteristic are not plausible.  
 10: Saturation characteristic could not be sensibly determined because load torque too large.

**Remedy:**

Re fault value = 1:  
 - the total drive moment of inertia is far higher than that of the motor (refer to p0341, p0342).  
 De-select rotating measurement (p1960), enter the moment of inertia p342, re-calculate the speed controller p0340 = 4 and repeat the measurement.

Re fault value = 1 ... 4:  
 - check the motor parameters (rating plate data).  
 - carry-out a motor data identification routine (p1910).  
 - if required, reduce the dynamic factor (p1967 < 25 %).

Re fault value = 5:  
 The speed setpoint (p1961) is too high. Reduce the speed.

Re fault value = 6:  
 Adapt the speed setpoint (p1961) or minimum limiting (p1080).

Re fault value = 7:  
 Adapt the speed setpoint (p1961) or suppression (skip) bandwidths (p1091 ... p1094, p1101).

Re fault value = 8:  
 Adapt the speed setpoint (p1961) or maximum limiting (p1082, p1083 and p1086).

Re fault value = 9, 10:  
 The measurement was carried-out at an operating point where the load torque is too high. Select a more suitable operating point, either by changing the speed setpoint (p1961) or by reducing the load torque. The load torque may not be varied while making measurements.

Note:  
 The saturation characteristic identification routine can be disabled using p1959.1.  
 See also: p1959 (Rotating measurement configuration)

---

**F07984 Drive: Speed controller optimization, moment of inertia**

**Reaction:** OFF1 (NONE, OFF2)

**Acknowledge:** IMMEDIATELY

**Cause:** A fault has occurred while identifying the moment of inertia.  
 Fault value (r0949, decimal):

- 1: The speed did not reach a steady-state condition.
- 2: The speed setpoint was not able to be approached as the minimum limiting is active.
- 3: The speed setpoint was not able to be approached as the suppression (skip) bandwidth is active.
- 4: The speed setpoint was not able to be approached as the maximum limiting is active.
- 5: It is not possible to increase the speed by 10% as the minimum limiting is active.
- 6: It is not possible to increase the speed by 10% as the suppression (skip) bandwidth is active.
- 7: It is not possible to increase the speed by 10% as the maximum limiting is active.
- 8: The torque difference after the speed setpoint step is too low in order to be able to still reliably identify the moment of inertia.
- 9: Too few data to be able to reliably identify the moment of inertia.
- 10: After the setpoint step, the speed either changed too little or in the incorrect direction.
- 11: The identified moment of inertia is not plausible.

**Remedy:**

Re fault value = 1:  
 - check the motor parameters (rating plate data).  
 - carry-out a motor data identification routine (p1910).  
 - if required, reduce the dynamic factor (p1967 < 25 %).

Re fault value = 2, 5:  
 Adapt the speed setpoint (p1965) or minimum limiting (p1080).

Re fault value = 3, 6:  
 Adapt the speed setpoint (p1965) or suppression (skip) bandwidths (p1091 ... p1094, p1101).

Re fault value = 4, 7:  
 Adapt the speed setpoint (p1965) or maximum limiting (p1082, p1083 and p1086).

Re fault value = 8:  
 Adapt the moment of inertia (p0341, p0342).

Note:  
 The moment of inertia identification routine can be disabled using p1959.2.  
 See also: p1959 (Rotating measurement configuration)

---

**F07985 Drive: Speed controller optimization (oscillation test)**

**Reaction:** OFF1 (NONE, OFF2)

**Acknowledge:** IMMEDIATELY

**Cause:** A fault has occurred during the vibration test.  
 Fault value (r0949, decimal):  
 1: The speed did not reach a steady-state condition.  
 2: The speed setpoint was not able to be approached as the minimum limiting is active.  
 3: The speed setpoint was not able to be approached as the suppression (skip) bandwidth is active.  
 4: The speed setpoint was not able to be approached as the maximum limiting is active.  
 5: Torque limits too low for a torque step.  
 6: No suitable speed controller setting was found.

**Remedy:** Re fault value = 1:  
 - check the motor parameters.  
 - carry-out a motor data identification routine (p1910).  
 - if required, reduce the dynamic factor (p1967 < 25 %).  
 Re fault value = 2:  
 Adapt the speed setpoint (p1965) or minimum limiting (p1080).  
 Re fault value = 3:  
 Adapt the speed setpoint (p1965) or suppression (skip) bandwidths (p1091 ... p1094, p1101).  
 Re fault value = 4:  
 Adapt the speed setpoint (p1965) or maximum limiting (p1082, p1083 and p1086).  
 Re fault value = 5:  
 Increase the torque limits (e.g. p1520, p1521).  
 Re fault value = 6:  
 Reduce the dynamic factor (p1967).  
 Note:  
 The speed controller vibration test can be disabled using p1959.4.  
 See also: p1959 (Rotating measurement configuration)

---

**F07986 Drive: Rotating measurement ramp-function generator**

**Reaction:** OFF1 (NONE, OFF2)

**Acknowledge:** IMMEDIATELY

**Cause:** During the rotating measurements, problems with the ramp-function generator occurred.  
 Fault value (r0949, decimal):  
 1: The positive and negative direction of rotation is inhibited.

**Remedy:** Re fault value = 1:  
 Enable the direction of rotation (p1110 or p1111).

---

**A07987 Drive: Rotating measurement, no encoder available**

**Reaction:** NONE

**Acknowledge:** NONE

**Cause:** No encoder available. The rotating measurement was carried-out without encoder (sensorless).  
 Alarm value (r2124, decimal):  
 1: An encoder is not connected.  
 2: It involves a SINAMICS G drive unit that only supports sensorless closed-loop control.

**Remedy:** Re alarm value = 1:  
 Connect-up the encoder.  
 Re alarm value = 2:  
 None necessary.

---

**F07988 Drive: Rotating measurement, no configuration selected**

**Reaction:** OFF2 (NONE, OFF1)

**Acknowledge:** IMMEDIATELY

**Cause:** When configuring the rotating measurement (p1959), no function was selected.

**Remedy:** Select at least one function for automatic optimization of the speed controller (p1959).  
 See also: p1959 (Rotating measurement configuration)

<b>F07990</b>	<b>Drive: Incorrect motor data identification</b>
<b>Reaction:</b>	OFF2 (NONE, OFF1)
<b>Acknowledge:</b>	IMMEDIATELY
<b>Cause:</b>	<p>A fault has occurred during the identification routine.</p> <p>Fault value (r0949, decimal):</p> <ol style="list-style-type: none"> <li>1: Current limit value reached.</li> <li>2: Identified stator resistance lies outside the expected range 0.1 ... 100 % of Zn.</li> <li>3: Identified rotor resistance lies outside the expected range 0.1 ... 100 % of Zn.</li> <li>4: Identified stator reactance lies outside the expected range 50 ... 500 % of Zn.</li> <li>5: Identified magnetizing reactance lies outside the expected range 50 ... 500 % of Zn.</li> <li>6: Identified rotor time constant lies outside the expected range 10 ms ... 5 s.</li> <li>7: Identified total leakage reactance lies outside the expected range 4 ... 50 % of Zn.</li> <li>8: Identified stator leakage reactance lies outside the expected range 2 ... 50 % of Zn.</li> <li>9: Identified rotor leakage reactance lies outside the expected range 2 ... 50 % of Zn.</li> <li>10: Motor has been incorrectly connected.</li> <li>11: Motor shaft rotates.</li> <li>20: Identified threshold voltage of the semiconductor devices lies outside the expected range 0 ... 10 V.</li> <li>30: Current controller in voltage limiting.</li> <li>40: At least one identification contains errors. The identified parameters are not saved to prevent inconsistencies.</li> <li>50: With the selected current controller sampling rate, the pulse frequency cannot be implemented.</li> </ol> <p>Note:</p> <p>Percentage values are referred to the rated motor impedance:  <math>Z_n = V_{mot,nom} / \sqrt{3} / I_{mot,nom}</math></p> <ol style="list-style-type: none"> <li>101: Voltage amplitude even at 30% maximum current amplitude is too low to measure the inductance.</li> <li>102, 104: Voltage limiting while measuring the inductance.</li> <li>103: Maximum frequency exceeded during the rotating inductance measurement.</li> <li>110: Motor not finely synchronized before the rotating measurement.</li> <li>120: Error when evaluating the magnetizing inductance.</li> <li>125: Cable resistance greater than the total resistance.</li> <li>126: Series inductance greater than the total leakage inductance.</li> <li>127: Identified leakage inductance negative.</li> <li>128: Identified stator resistance negative.</li> <li>129: Identified rotor resistance negative.</li> <li>130: Drive data set changeover during the motor data identification routine.</li> <li>140: The setpoint channel inhibits both directions of rotation.</li> <li>160: Accelerating time when determining the moment of inertia or reluctance torque too short.</li> <li>173: Internal problem.</li> <li>180: Identification speed (maximum speed, rated speed, <math>0.9 * p0348</math>) less than p1755.</li> <li>190: Speed setpoint not equal to zero.</li> <li>191: An actual speed of zero is not reached.</li> <li>192: Speed setpoint not reached.</li> <li>200, 201: Not possible to identify the voltage emulation error characteristic of the drive converter (p1952, p1953).</li> </ol>
<b>Remedy:</b>	<p>Re fault value = 0:  Check whether the motor is correctly connected. Observe the configuration (star-delta).</p> <p>Re fault value = 1 ... 40:  - check whether the motor data have been correctly entered into p0300, p0304 - p0311.  - is there an appropriate relationship between the motor power rating and that of the Motor Module? The ratio of the Motor Module to the rated motor current should not be less than 0.5 and should not be greater than 4.  - check the motor configuration (star-delta).</p> <p>Re fault value = 4, 7:  Check whether inductances are correctly entered in p0233 and p0353.</p> <p>Re fault value = 50:  Reduce the current controller sampling rate.</p> <p>Re fault value = 101:  Increase current limit (p0640).  Check the current controller gain (p1715).  Reduce the current controller sampling time (p0115).  It may be impossible to completely identify the L characteristic, as the required current amplitude is too high.  Suppress measurement (p1909, p1959).</p> <p>Re fault value = 102, 104:  Reduce the current limit (p0640).  Check the current controller P gain.</p>

Suppress measurement (p1909, p1959).  
 Re fault value = 103:  
 Increase the external moment of inertia (if possible).  
 Reduce the current controller sampling time (p0115).  
 Suppress measurement (p1909, p1959).  
 Re fault value 110:  
 Before the rotating measurement, traverse the motor over the zero mark.  
 Re fault value 120:  
 Check the current controller P gain (p1715) and if required, reduce.  
 Increase the pulse frequency (p1800).  
 Re fault 125:  
 Reduce the cable resistance (p0352).  
 Re fault 126:  
 Reduce the series inductance (p0353).  
 Re fault 127, 128, 129:  
 It is possible that the current controller is oscillating. Reduce p1715 before the next measurement.  
 Re fault 130:  
 Do not initiate a drive data set changeover during the motor identification routine.  
 Re fault value 140:  
 Before the measurement, enable at least one direction of rotation (value of p1110 = 0 or value of p1111 = 0 or p1959.14 = 1 or p1959.15 = 1).  
 Re fault value = 160:  
 Extend the accelerating time when determining the moment of inertia and reluctance torque, e.g. by increasing the maximum speed (p1082), increasing the moment of inertia or reducing the maximum current (p0640).  
 Increase the speed controller P-gain (p1460).  
 Suppress measurement (p1959).  
 Re fault value 173:  
 -  
 Re fault value 180:  
 Increase the maximum speed (p1082).  
 Reduce p1755.  
 Suppress measurement (p1909, p1959).  
 Re fault value 190:  
 Set the speed setpoint to zero.  
 Re fault value 191:  
 Do not start the motor data identification routine while the motor is still rotating.  
 Re fault value = 192:  
 Check the closed-loop speed control (the motor rotor may be locked or the closed-loop speed control is not functioning).  
 Ensure that the enable signals are present during the measurement.  
 Remove any pulling loads from the motor.  
 Increase the maximum current (p0640).  
 Reduce the maximum speed (p1082).  
 Suppress measurement (p1959).  
 Re fault value = 200, 201:  
 - set the pulse frequency to 0.5 \* current controller frequency (e.g. 4 kHz for a current controller clock cycle of 125 us).  
 - reduce the cable length between the Motor Module and the motor.  
 - read-out measured values (r1950, r1951) and therefore determine suitable values for p1952, p1953 according to your own estimation.

---

<b>A07991 (N)</b>	<b>Drive: Motor data identification activated</b>
<b>Reaction:</b>	NONE
<b>Acknowledge:</b>	NONE
<b>Cause:</b>	The motor data identification routine is activated. The motor data identification routine is carried-out at the next power-on command. See also: p1910 (Motor data identification routine, stationary (standstill))
<b>Remedy:</b>	None necessary. The alarm automatically disappears after the motor data identification routine has been successfully completed or for the setting p1910 = 0 or p1960 = 0.
Reaction upon N:	NONE
Acknowledge upon N:	NONE



---

<b>F07993</b>	<b>Drive: Incorrect direction of rotation of the field or encoder actual value inversion</b>
<b>Reaction:</b>	OFF2 (NONE)
<b>Acknowledge:</b>	IMMEDIATELY
<b>Cause:</b>	Either the direction of the rotating field or the encoder actual value has an incorrect sign. The motor data identification automatically changed the actual value inversion (p0410) in order to correct the control sense. This can result in a direction of rotation change. To acknowledge this fault, the correctness of the direction of rotation must first be acknowledged with p1910 = -2.
<b>Remedy:</b>	Check the direction of rotation, also for the position controller, if one is being used. If the direction of rotation is correct, the following applies: No additional measures are required (except p1910 = -2 and acknowledge fault). If the direction of rotation is incorrect, the following applies: To change the direction of rotation, two phases must be interchanged and the motor identification routine must be repeated.

---

<b>F07995</b>	<b>Drive: Pole position identification not successful</b>
<b>Reaction:</b>	OFF2
<b>Acknowledge:</b>	IMMEDIATELY
<b>Cause:</b>	The pole position identification routine was unsuccessful. Fault value (r0949, decimal): 1: No current is established. 2: The starting current is not zero. 3: The selected maximum distance was exceeded (p1981). 4x: The measuring signal does not permit a clear evaluation. 5: The maximum current was exceeded during the measurement. 6: The current measurement must be re-calibrated. 7x: The Sensor Module does not support the pole position identification routine. 70 ... 79: Only for internal Siemens troubleshooting. 8: The pole position identification routine current required is greater than the maximum current. 9: The set pole position identification routine current is zero. 10: Data set changeover during the pole position identification 100: Motion-based pole position identification, 1st and 2nd measurement different. Motor locked or current (p1993) too low. 101: Motion-based position position identification, insufficient motion, motor locked or current (p1993) too low. 102: Motion-based pole position identification, brake is being used and is closed. The motion-based position position identification in conjunction with the brake is not permitted. 103: Motion-based pole position identification without encoder. 104: Motion-based pole position identification, speed actual value not zero after stabilizing time. Note: x = 0 ... 9
<b>Remedy:</b>	Re fault value = 1: Check the motor connection and DC link voltage. For the following parameters, set practical values that are not zero (p0325, p0329). Re fault value = 3: Increase the maximum distance (p1981). Reduce the currents for the pole position identification routine (p0325, p0329). Stop the motor in order to carry-out the pole position identification routine. Re fault value = 40 ... 49: Increase the currents for the pole position identification routine (p0325, p0329). Stop the motor in order to carry-out the pole position identification routine. Select another technique for pole position identification routine (p1980). Use another motor, absolute encoder or Hall sensors. Re fault value = 5: Reduce the currents for the pole position identification routine (p0325, p0329). Re fault value = 6: Re-calibrate the Motor Module. Re fault value = 7x: Upgrade the software in the Sensor Module. Re fault value = 8: Reduce the currents for the pole position identification routine (p0329, p0325, p1993). The power unit cannot provide the necessary pole position identification routine current (p0209 < p0329, p0325, p1993), replace the power unit by a power unit with a higher maximum current.

Re fault value = 9:  
 Enter a value not equal to zero in the pole position identification routine current (p0329, p0325, p1993).  
 Re fault value = 10:  
 Do not initiate a data set changeover during the pole position identification.  
 Re fault value = 100, 101:  
 Check and ensure that the motor is free to move.  
 Increase the current for motion-based pole position identification (p1993).  
 Re fault value = 102:  
 If the motor is to be operated with a brake: Select a different technique to identify the pole position (p1980).  
 If the motor can be operated without a brake: Open the brake (p1215 = 2).  
 Re fault value = 103:  
 The motion-based pole position identification can only be carried-out using an encoder. Connect an encoder or select another technique for pole position identification routine (p1980).  
 Re fault value = 104:  
 Pole position identification, increase the smoothing time, motion-based (p1997).  
 Pole position identification, increase the rise time, motion-based (p1994).  
 Pole position identification, check the gain, motion-based (p1995).  
 Pole position identification, check the integral time, motion-based (p1996).

---

**F07996 Drive: Pole position identification routine not carried-out**  
**Reaction:** ENCODER (OFF2)  
**Acknowledge:** IMMEDIATELY  
**Cause:** The drive was changed over, flying, from sensorless operation to operation with encoder without having previously carried-out a pole position identification for the encoder. p1404 is then at a value between zero and the maximum speed and the pulses in the speed range above p1404 were enabled without a pole position identification routine having been previously carried-out in operation with encoder.  
**Remedy:** For a flying changeover between operation with and without encoder with pole position identification after POWER ON or commissioning (p0010 not equal to zero) enable the pulses once at zero speed. This means that the pole position identification routine is carried-out and the result is available for operation.

---

**F08000 (N, A) TB: +/-15 V power supply faulted**  
**Reaction:** A\_INFEED: NONE (OFF1, OFF2)  
 SERVO: NONE (DCBRAKE, OFF1, OFF2, OFF3, STOP1, STOP2)  
 VECTOR: NONE (DCBRAKE, OFF1, OFF2, OFF3, STOP1, STOP2)  
**Acknowledge:** IMMEDIATELY (POWER ON)  
**Cause:** Terminal Board 30 detects an incorrect internal power supply voltage.  
 Fault value (r0949, decimal):  
 0: Error when testing the monitoring circuit.  
 1: Fault in normal operation.  
**Remedy:**  
 - replace Terminal Board 30.  
 - replace Control Unit.  
 Reaction upon N: NONE  
 Acknowledge upon N: NONE  
 Reaction upon A: NONE  
 Acknowledge upon A: NONE

---

**F08010 (N, A) TB: Analog-digital converter**  
**Reaction:** A\_INFEED: NONE (OFF1, OFF2)  
 SERVO: NONE (DCBRAKE, OFF1, OFF2, OFF3, STOP1, STOP2)  
 VECTOR: OFF1 (DCBRAKE, NONE, OFF2, OFF3, STOP1, STOP2)  
**Acknowledge:** IMMEDIATELY (POWER ON)  
**Cause:** The analog/digital converter on Terminal Board 30 has not supplied any converted data.  
**Remedy:**  
 - check the power supply.  
 - replace Terminal Board 30.  
 Reaction upon N: NONE  
 Acknowledge upon N: NONE

Reaction upon A: NONE  
Acknowledge upon A: NONE

---

**F08500 (A)      COMM BOARD: Monitoring time, configuration expired**

**Reaction:** A\_INFEED: OFF1 (OFF2)  
SERVO: OFF1 (OFF2, OFF3)  
VECTOR: OFF1 (OFF2, OFF3)

**Acknowledge:** IMMEDIATELY

**Cause:** The monitoring time for the configuration has expired.  
Fault value (r0949, decimal):  
0: The transfer of the send-configuration data has been exceeded (time).  
1: The transfer of the receive-configuration data has been exceeded (time).

**Remedy:** Check communication line.

Reaction upon A: NONE  
Acknowledge upon A: NONE

---

**F08501 (A)      COMM BOARD: Monitoring time, process data expired**

**Reaction:** A\_INFEED: OFF1 (OFF2)  
SERVO: OFF1 (OFF2, OFF3)  
VECTOR: OFF1 (OFF2, OFF3)

**Acknowledge:** IMMEDIATELY

**Cause:** The set monitoring time expired while transferring process data via COMM BOARD.  
See also: p2040 (COMM INT monitoring time)

**Remedy:** - check communications link.  
- check the set monitoring time if the error persists.  
See also: p2040 (COMM INT monitoring time)

Reaction upon A: NONE  
Acknowledge upon A: NONE

---

**F08502 (A)      COMM BOARD: Monitoring time, sign-of-life expired**

**Reaction:** A\_INFEED: OFF1 (OFF2)  
SERVO: OFF1 (OFF2, OFF3)  
VECTOR: OFF1 (OFF2, OFF3)

**Acknowledge:** IMMEDIATELY

**Cause:** The monitoring time for the sign-of-life counter has expired.

**Remedy:** Check communication line.

Reaction upon A: NONE  
Acknowledge upon A: NONE

---

**A08504 (F)      COMM BOARD: Internal cyclic data transfer error**

**Reaction:** NONE

**Acknowledge:** NONE

**Cause:** The cyclic actual and/or setpoint values were not transferred within the specified times.  
Alarm value (r2124, decimal):  
Only for internal Siemens troubleshooting.

**Remedy:** Check the parameterizing telegram (Ti, To, Tdp, etc.).

Reaction upon F: A\_INFEED: NONE (OFF1, OFF2)  
SERVO: NONE (OFF1, OFF2, OFF3)  
VECTOR: NONE (OFF1, OFF2, OFF3)

Acknowledge upon F: IMMEDIATELY

<b>F08510 (A)</b>	<b>COMM BOARD: Send configuration data invalid</b>
<b>Reaction:</b>	A_INFEED: OFF1 (OFF2) SERVO: OFF1 (OFF2, OFF3) VECTOR: OFF1 (OFF2, OFF3)
<b>Acknowledge:</b>	IMMEDIATELY
<b>Cause:</b>	COMM BOARD did not accept the send-configuration data. Fault value (r0949, decimal): Return value of the send-configuration data check.
<b>Remedy:</b>	Check the send configuration data.
Reaction upon A:	NONE
Acknowledge upon A:	NONE
<b>A08511 (F)</b>	<b>COMM BOARD: Receive configuration data invalid</b>
<b>Reaction:</b>	NONE
<b>Acknowledge:</b>	NONE
<b>Cause:</b>	The drive unit did not accept the receive-configuration data. Alarm value (r2124, decimal): Return value of the receive-configuration data check. 0: Configuration accepted. 1: Connection established to more drive objects than configured in the device. The drive objects for process data exchange and their sequence was defined using p0978. 2: Too many data words for input or output to a drive object. A max. of 16 words is permitted for SERVO and VECTOR; max. 5 words, for A_INFEED, TB30, TM31 and CU320. 3: Uneven number of bytes for input or output. 4: Setting data for synchronization not accepted. 5: Drive still not in cyclic operation. 6: Buffer system not accepted. 7: Cyclic channel length too short for this setting. 8: Cyclic channel address not initialized. 9: 3-buffer system not permitted. 10: DRIVE-CLiQ fault. 11: CU link fault. 12: CX32 not in cyclic operation.
<b>Remedy:</b>	Check the receive configuration data. Re alarm value = 1: Check the list of the drive objects with process data exchange (p0978). With p0978[x] = 0, all of the following drive objects in the list are excluded from the process data exchange.
Reaction upon F:	A_INFEED: NONE (OFF1, OFF2) SERVO: NONE (OFF1, OFF2, OFF3) VECTOR: NONE (OFF1, OFF2, OFF3)
Acknowledge upon F:	IMMEDIATELY
<b>A08520 (F)</b>	<b>COMM BOARD: Non-cyclic channel error</b>
<b>Reaction:</b>	NONE
<b>Acknowledge:</b>	NONE
<b>Cause:</b>	The memory or the buffer status of the non-cyclic channel has an error. Alarm value (r2124, decimal): 0: Error in the buffer status. 1: Error in the memory.
<b>Remedy:</b>	Check communication line.
Reaction upon F:	A_INFEED: NONE (OFF1, OFF2) SERVO: NONE (OFF1, OFF2, OFF3) VECTOR: NONE (OFF1, OFF2, OFF3)
Acknowledge upon F:	IMMEDIATELY

<b>A08530 (F)</b>	<b>COMM BOARD: Message channel error</b>
<b>Reaction:</b>	NONE
<b>Acknowledge:</b>	NONE
<b>Cause:</b>	The memory or the buffer status of the message channel has an error. Alarm value (r2124, decimal): 0: Error in the buffer status., 1: Error in the memory.
<b>Remedy:</b>	Check communication line.
<b>Reaction upon F:</b>	A_INFEED: NONE (OFF1, OFF2) SERVO: NONE (OFF1, OFF2, OFF3) VECTOR: NONE (OFF1, OFF2, OFF3)
<b>Acknowledge upon F:</b>	IMMEDIATELY
<b>F08700 (A)</b>	<b>CBC: Communications error</b>
<b>Reaction:</b>	A_INFEED: NONE SERVO: OFF3 (NONE, OFF1, OFF2) VECTOR: OFF3 (NONE, OFF1, OFF2)
<b>Acknowledge:</b>	IMMEDIATELY
<b>Cause:</b>	A CAN communications error has occurred. Fault value (r0949, decimal): 1: The error counter for the send telegrams has exceeded the BUS OFF value 255. The bus disables the CAN controller. - bus cable interrupted. - bus cable not connected. - incorrect baud rate. - incorrect bit timing. 2: The master no longer interrogated the CAN node status longer than for its "life time". The "life time" is obtained from the "guard time" (p8604[0]) multiplied by the "life time factor" (p8604[1]). - bus cable interrupted. - bus cable not connected. - incorrect baud rate. - incorrect bit timing. - master fault.
<b>Remedy:</b>	Note: The fault response can be set as required using p8641. See also: p8604 (CBC node guarding), p8641 (CBC abort connection option code) - check the bus cable - check the baud rate (p8622). - check the bit timing (p8623). - check the master. See also: p8622 (CBC baud rate), p8623 (CBC bit timing selection)
<b>Reaction upon A:</b>	NONE
<b>Acknowledge upon A:</b>	NONE
<b>F08701</b>	<b>CBC: NMT state change</b>
<b>Reaction:</b>	A_INFEED: OFF2 SERVO: OFF3 VECTOR: OFF3
<b>Acknowledge:</b>	IMMEDIATELY
<b>Cause:</b>	A CANopen NMT state transition from "operational" to "pre-operational" or after "stopped". Fault value (r0949, decimal): 1: CANopen NMT state transition from "operational" to "pre-operational". 2: CANopen NMT state transition from "operational" to "stopped". Note: In the NMT state "pre-operational", process data cannot be transferred and in the NMT state "stopped", no process data and no service data can be transferred.
<b>Remedy:</b>	None necessary. Acknowledge the fault and continue operation.

<b>A08751</b>	<b>CBC: Telegram loss</b>
<b>Reaction:</b>	NONE
<b>Acknowledge:</b>	NONE
<b>Cause:</b>	The CAN controller has lost a receive message (telegram).
<b>Remedy:</b>	Reduce the cycle times of the receive messages.
<b>A08752</b>	<b>CBC: Error counter for error passive exceeded</b>
<b>Reaction:</b>	NONE
<b>Acknowledge:</b>	NONE
<b>Cause:</b>	The error counter for the send or receive telegrams has exceeded the value 127.
<b>Remedy:</b>	<ul style="list-style-type: none"> <li>- check the bus cable</li> <li>- set a higher baud rate (p8622).</li> <li>- check the bit timing and if required optimize (p8623).</li> </ul> See also: p8622 (CBC baud rate), p8623 (CBC bit timing selection)
<b>A08753</b>	<b>CBC: Message buffer overflow</b>
<b>Reaction:</b>	NONE
<b>Acknowledge:</b>	NONE
<b>Cause:</b>	A message buffer overflow. Alarm value (r2124, decimal): 1: Non-cyclic send buffer (SDO response buffer) overflow. 2: Non-cyclic receive buffer (SDO receive buffer) overflow. 3: Cyclic send buffer (PDO send buffer) overflow.
<b>Remedy:</b>	Check the bus cable. Set a higher baud rate (p8622). Check the bit timing and if required optimize (p8623). Re alarm value = 2: - reduce the cycle times of the SDO receive messages. See also: p8622 (CBC baud rate), p8623 (CBC bit timing selection)
<b>A08754</b>	<b>CBC: Incorrect communications mode</b>
<b>Reaction:</b>	NONE
<b>Acknowledge:</b>	NONE
<b>Cause:</b>	In the "operational" mode, an attempt was made to change parameters p8700 ... p8737.
<b>Remedy:</b>	Change into the "pre-operational" or "stopped" mode.
<b>A08755</b>	<b>CBC: Obj cannot be mapped</b>
<b>Reaction:</b>	NONE
<b>Acknowledge:</b>	NONE
<b>Cause:</b>	The CANopen object is not provided for the Process Data Object (PDO) Mapping.
<b>Remedy:</b>	Use a CANopen object intended for the PDO mapping or enter 0. The following objects can be mapped in the Receive Process Data Object (RPDO) or Transmit Process Data Object (TPDO): - RPDO: 6040 hex, 6060 hex, 60FF hex, 6071 hex. - TPDO: 6041 hex, 6061 hex, 6063 hex, 6069 hex, 606B hex, 606C hex, 6074 hex. Note: As long as A08755 is present, the COB-ID cannot be set to valid.
<b>A08756</b>	<b>CBC: Number of mapped bytes exceeded</b>
<b>Reaction:</b>	NONE
<b>Acknowledge:</b>	NONE
<b>Cause:</b>	The number of bytes of the mapped objects exceeds the telegram size for net data. A maximum of 8 bytes is permissible.

**Remedy:** Map fewer objects or objects with a smaller data type.  
 See also: p8710 (CBC receive mapping for RPDO 1), p8711 (CBC receive mapping for RPDO 2), p8712 (CBC receive mapping for RPDO 3), p8713 (CBC receive mapping for RPDO 4), p8714 (CBC receive mapping for RPDO 5), p8715 (CBC receive mapping for RPDO 6), p8716 (CBC receive mapping for RPDO 7), p8717 (CBC receive mapping for RPDO 8), p8730 (CBC send mapping for TPDO 1), p8731 (CBC send mapping for TPDO 2), p8732 (CBC send mapping for TPDO 3), p8733 (CBC send mapping for TPDO 4), p8734 (CBC send mapping for TPDO 5), p8735 (CBC send mapping for TPDO 6), p8736 (CBC send mapping for TPDO 7), p8737 (CBC send mapping for TPDO 8)

---

**A08757 CBC: Set COB-ID invalid**

**Reaction:** NONE

**Acknowledge:** NONE

**Cause:** For online operation, the appropriate COB-ID must be set invalid before mapping.

Example:

Mapping for RPDO 1 should be changed (p8710[0]).

--> set p8700[0] = C00006E0 hex (invalid COB-ID)

--> set p8710[0] as required.

--> p8700[0] enter a valid COB-ID

**Remedy:** Set the COB-ID to invalid.

---

**A08758 CBC: Number of PDO channels too low**

**Reaction:** NONE

**Acknowledge:** NONE

**Cause:** The number of PDO channels in p8740 has either been set to 0 or too low.

See also: p8740 (CBC channel assignment)

**Remedy:** The number of channels set in p8740 must be greater than or equal to the number of PDOs.

There are 2 possibilities:

Increase the number of channels in p8740 and confirm the selection using p8741.

Reduce the number of PDOs by setting the COB-ID to invalid.

See also: p8740 (CBC channel assignment), p8741 (CBC PDO configuration acknowledgement)

---

**A08759 CBC: PDO COB-ID already available**

**Reaction:** NONE

**Acknowledge:** NONE

**Cause:** An existing PDO COB-ID was allocated.

**Remedy:** Select another PDO COB-ID.

---

**A13000 License not adequate**

**Reaction:** NONE

**Acknowledge:** NONE

**Cause:** - for the drive unit, the options that require a license are being used but the licenses are not sufficient.

- an error occurred when checking the existing licenses.

Alarm value (r2124, decimal):

0:

The existing license is not sufficient.

1:

An adequate license was not able to be determined as the CompactFlash card with the required licensing data was withdrawn in operation.

2:

An adequate license was not able to be determined, as an error occurred when reading-out the required licensing data from the CompactFlash card.

3:

An adequate license was not able to be determined as there is a checksum error in the license key.

4:

An internal error occurred when checking the license.

**Remedy:**

- Alarm value 0:  
Additional licenses are required and these must be activated (p9920, p9921).
- Alarm value 1:  
With the system powered-down, re-insert the CompactFlash card that matches the system.
- Alarm value 2:  
Enter and activate the license key (p9920, p9921).
- Alarm value 3:  
Compare the license key (p9920) entered with the license key on the certificate of license.  
Re-enter the license key and activate (p9920, p9921).
- Alarm value 4:  
  - carry-out a POWER ON.
  - upgrade the firmware release.
  - contact the Hotline.

---

**A13001 Error in license checksum**

**Reaction:** NONE  
**Acknowledge:** NONE  
**Cause:** When checking the checksum of the license key, an error was detected.  
**Remedy:** Compare the license key (p9920) entered with the license key on the certificate of license.  
 Re-enter the license key and activate (p9920, p9921).

---

**F30001 Power unit: Overcurrent**

**Reaction:** OFF2  
**Acknowledge:** IMMEDIATELY  
**Cause:** The power unit has detected an overcurrent condition.  
 - closed-loop control is incorrectly parameterized.  
 - motor has a short-circuit or fault to ground (frame).  
 - U/f operation: Up ramp set too low.  
 - U/f operation: Rated motor current is significantly greater than that of the Motor Module.  
 - infeed: High discharge and post-charging current for line supply voltage interruptions.  
 - infeed: High post-charging currents for overload when motoring and DC link voltage dip.  
 - infeed: Short-circuit currents at power-on due to the missing commutating reactor.  
 - power cables are not correctly connected.  
 - power cables exceed the maximum permissible length.  
 - power unit defective.  
 Fault value (r0949):  
 Bit 0: Phase U.  
 Bit 1: Phase V.  
 Bit 2: Phase W.

**Remedy:**

- check the motor data - if required, carry-out commissioning.
- check the motor circuit configuration (star-delta).
- U/f operation: Increase up ramp.
- U/f operation: Check the assignment of the rated currents of the motor and Motor Module.
- infeed: Check the line supply quality.
- infeed: Reduce the load when motoring.
- infeed: Correct connection of the line commutating reactor.
- check the power cable connections.
- check the power cables for short-circuit or ground fault.
- check the length of the power cables.
- replace power unit.



<b>F30002</b>	<b>Power unit: DC link overvoltage</b>
<b>Reaction:</b>	OFF2
<b>Acknowledge:</b>	IMMEDIATELY
<b>Cause:</b>	<p>The power unit has detected an overvoltage condition in the DC link.</p> <ul style="list-style-type: none"> <li>- motor regenerates too much energy.</li> <li>- line supply voltage too high.</li> <li>- when operating with a VSM, the phase assignment L1, L2, L3 at the VSM differs from the phase assignment at the power unit.</li> </ul> <p>Fault value (r0949, decimal): DC link voltage [1 bit = 100 mV]. For SINAMICS GM/SM, the following applies: Fault value (r0949, decimal): 32: Overvoltage in the negative partial DC link (VdcP) 64: Overvoltage in the positive partial DC link (VdcN) 96: Overvoltage in both partial -DC links</p>
<b>Remedy:</b>	<ul style="list-style-type: none"> <li>- increase the ramp-down time.</li> <li>- activate the DC link voltage controller.</li> <li>- use a brake resistor or Active Line Module.</li> <li>- increase the current limit of the infeed or use a larger module (for the Active Line Module).</li> <li>- check the line supply voltage.</li> <li>- check and correct the phase assignment at the VSM and at the power unit.</li> </ul> <p>See also: p0210 (Drive unit line supply voltage), p1240 (Vdc controller or Vdc monitoring configuration)</p>
<b>F30003</b>	<b>Power unit: DC link undervoltage</b>
<b>Reaction:</b>	OFF2
<b>Acknowledge:</b>	IMMEDIATELY
<b>Cause:</b>	<p>The power unit has detected an undervoltage condition in the DC link.</p> <ul style="list-style-type: none"> <li>- line supply failure</li> <li>- line supply voltage below the permissible value.</li> <li>- line supply infeed failed or faulted.</li> </ul> <p>Note: The monitoring threshold for the DC link undervoltage is the minimum of the following values: - 85% of the unit supply voltage (p0210). - lowest permissible lower DC link voltage of the power units (descriptive data).</p>
<b>Remedy:</b>	<ul style="list-style-type: none"> <li>- check the line supply voltage</li> <li>- check the line supply infeed and if necessary observe the fault messages of the line supply infeed.</li> </ul> <p>Note: The ready signal of the infeed r0863 must be connected to the associated inputs p0864 of the drives. See also: p0210 (Drive unit line supply voltage)</p>
<b>F30004</b>	<b>Power unit: Overtemperature heatsink AC inverter</b>
<b>Reaction:</b>	OFF2
<b>Acknowledge:</b>	IMMEDIATELY
<b>Cause:</b>	<p>The temperature of the power unit heatsink has exceeded the permissible limit value.</p> <ul style="list-style-type: none"> <li>- insufficient cooling, fan failure.</li> <li>- overload</li> <li>- ambient temperature too high.</li> <li>- pulse frequency too high.</li> </ul> <p>Fault value (r0949): Temperature [1 bit = 0.01 °C].</p>
<b>Remedy:</b>	<ul style="list-style-type: none"> <li>- check whether the fan is running.</li> <li>- check the fan elements</li> <li>- check whether the ambient temperature is in the permissible range.</li> <li>- check the motor load.</li> <li>- reduce the pulse frequency if this is higher than the rated pulse frequency.</li> </ul> <p>Notice: This fault can only be acknowledged after this alarm threshold for alarm A05000 has been fallen below. See also: p1800 (Pulse frequency)</p>

<b>F30005</b>	<b>Power unit: I2T overload</b>
<b>Reaction:</b>	OFF2
<b>Acknowledge:</b>	IMMEDIATELY
<b>Cause:</b>	The power unit was overloaded (r0036 = 100 %). - the permissible rated power unit current was exceeded for an inadmissibly long time. - the permissible load duty cycle was not maintained. Fault value (r0949, decimal): I2t [100 % = 16384].
<b>Remedy:</b>	- reduce the continuous load. - adapt the load duty cycle. - check the motor and power unit rated currents. See also: r0036 (Power unit overload I2t), r0206 (Rated power unit power), p0307 (Rated motor power)
<b>F30006</b>	<b>Power unit: Thyristor Control Board</b>
<b>Reaction:</b>	OFF2
<b>Acknowledge:</b>	IMMEDIATELY
<b>Cause:</b>	The thyristor control board of the Basic Line Module signals a fault. - there is not line supply voltage. - the line contactor is not closed. - the line supply voltage is too low. - line supply frequency outside the permissible range (45 ... 66 Hz). - there is a DC link short-circuit. - there is a DC link short-circuit (during the pre-charging phase). - power supply thyristor control board outside the nominal range (5 ... 18 V) and supply voltage >30 V. - there is an internal fault in the thyristor control board.
<b>Remedy:</b>	The faults are saved in the TCB and are acknowledged by switching-out the TCB supply voltage for at least 10 s! - check the line supply voltage - check or energize the line contactor. - check the monitoring time and, if required, increase (p0857). - if required, observe additional power unit messages/signals. - check the DC link regarding short-circuit or ground fault. - observe the LED fault display of the thyristor control board.
<b>F30008</b>	<b>Power unit: Sign-of-life error, cyclic data</b>
<b>Reaction:</b>	A_INFEED: NONE (OFF1, OFF2) SERVO: NONE (OFF1, OFF2, OFF3) VECTOR: NONE (OFF1, OFF2, OFF3)
<b>Acknowledge:</b>	IMMEDIATELY
<b>Cause:</b>	A DRIVE-CLiQ communications error has occurred between the Control Unit and the power unit involved. The cyclic setpoint telegrams of the Control Unit were not received on time by the power unit for at least two clock cycles within a time interval of 20 ms.
<b>Remedy:</b>	- check the electrical cabinet design and cable routing for EMC compliance.
<b>A30010 (F)</b>	<b>Power unit: Sign-of-life error, cyclic data</b>
<b>Reaction:</b>	NONE
<b>Acknowledge:</b>	NONE
<b>Cause:</b>	A DRIVE-CLiQ communications error has occurred between the Control Unit and the power unit involved. The cyclic setpoint telegrams of the Control Unit were not received on time by the power unit for at least one clock cycle.
<b>Remedy:</b>	- check the electrical cabinet design and cable routing for EMC compliance.
<b>Reaction upon F:</b>	A_INFEED: NONE (OFF1, OFF2) SERVO: NONE (OFF1, OFF2, OFF3) VECTOR: NONE (OFF1, OFF2, OFF3)
<b>Acknowledge upon F:</b>	IMMEDIATELY (POWER ON)

---

**F30011 Power unit: Line phase failure in main circuit**

**Reaction:** OFF2 (OFF1)  
**Acknowledge:** IMMEDIATELY  
**Cause:** A line phase failure was detected at the power unit.  
 - the fuse of a phase of a main circuit has ruptured.  
 - the DC link voltage ripple has exceeded the permissible limit value.  
**Remedy:** Check the fuses in the main circuit.

---

**F30012 Power unit: Temperature sensor heatsink wire breakage**

**Reaction:** OFF1 (OFF2)  
**Acknowledge:** IMMEDIATELY  
**Cause:** The connection to one of the heatsink temperature sensors in the power unit is interrupted.  
 Fault value (r0949, interpret hexadecimal):  
 Bit 0: Module slot (electronics slot)  
 Bit 1: Air intake  
 Bit 2: Inverter 1  
 Bit 3: Inverter 2  
 Bit 4: Inverter 3  
 Bit 5: Inverter 4  
 Bit 6: Inverter 5  
 Bit 7: Inverter 6  
 Bit 8: Rectifier 1  
 Bit 9: Rectifier 2  
 See also: r0949 (Fault value)  
**Remedy:** Contact the manufacturer.

---

**F30013 Power unit: Temperature sensor heatsink short-circuit**

**Reaction:** OFF1 (OFF2)  
**Acknowledge:** IMMEDIATELY  
**Cause:** The heatsink temperature sensor in the Motor Module is short-circuited.  
 Fault value (r0949, interpret hexadecimal):  
 Bit 0: Module slot (electronics slot)  
 Bit 1: Air intake  
 Bit 2: Inverter 1  
 Bit 3: Inverter 2  
 Bit 4: Inverter 3  
 Bit 5: Inverter 4  
 Bit 6: Inverter 5  
 Bit 7: Inverter 6  
 Bit 8: Rectifier 1  
 Bit 9: Rectifier 2  
**Remedy:** Contact the manufacturer.

---

**A30016 Power unit: Load supply switched-out**

**Reaction:** NONE  
**Acknowledge:** NONE  
**Cause:** The following applies for CU31x and CUA31:  
 The DC link voltage is too low.  
 Fault value (r0949, decimal):  
 DC link voltage in [V].  
**Remedy:** The following applies for CU31x and CUA31:  
 Under certain circumstances, the AC line supply is not switched-in.

<b>F30017</b>	<b>Power unit: Hardware current limit has responded too often</b>
<b>Reaction:</b>	OFF2
<b>Acknowledge:</b>	IMMEDIATELY
<b>Cause:</b>	<p>The hardware current limitation in the relevant phase (see A30031, A30032, A30033) has responded too often. The number of times the limit has been exceeded depends on the design and type of power unit.</p> <p>For infeed units, the following applies:</p> <ul style="list-style-type: none"> <li>- closed-loop control is incorrectly parameterized.</li> <li>- load on the infeed is too high.</li> <li>- Voltage Sensing Module incorrectly connected.</li> <li>- commutating reactor missing or the incorrect type.</li> <li>- power unit defective.</li> </ul> <p>The following applies to Motor Modules:</p> <ul style="list-style-type: none"> <li>- closed-loop control is incorrectly parameterized.</li> <li>- fault in the motor or in the power cables.</li> <li>- the power cables exceed the maximum permissible length.</li> <li>- motor load too high</li> <li>- power unit defective.</li> </ul> <p>Fault value (r0949, interpret binary):            Bit 0: Phase U            Bit 1: Phase V            Bit 2: Phase W</p>
<b>Remedy:</b>	<p>For infeed units, the following applies:</p> <ul style="list-style-type: none"> <li>- check the controller settings, if required, reset and identify the controller (p0340 = 2, p3410 = 5).</li> <li>- reduce the load, if required, increase the DC link capacitance or use a higher-rating infeed.</li> <li>- check the connection of the optional Voltage Sensing Module.</li> <li>- check the connection and technical data of the commutating reactor.</li> <li>- check the power cables for short-circuit or ground fault.</li> <li>- replace power unit.</li> </ul> <p>The following applies to Motor Modules:</p> <ul style="list-style-type: none"> <li>- check the motor data.</li> <li>- check the motor circuit configuration (star-delta).</li> <li>- check the motor load.</li> <li>- check the power cable connections.</li> <li>- check the power cables for short-circuit or ground fault.</li> <li>- check the length of the power cables.</li> <li>- replace power unit.</li> </ul>
<b>F30021</b>	<b>Power unit: Ground fault</b>
<b>Reaction:</b>	OFF2
<b>Acknowledge:</b>	IMMEDIATELY
<b>Cause:</b>	<p>Power unit has detected a ground fault.</p> <ul style="list-style-type: none"> <li>- ground fault in the power cables</li> <li>- winding fault or ground fault at the motor.</li> <li>- CT defective.</li> </ul> <p>Additional cause for CU310/CUA31:            - when the brake is applied, this causes the hardware DC current monitoring to respond.</p> <p>Fault value (r0949, decimal):            Absolute value, summed current [32767 = 271 % rated current].</p>
<b>Remedy:</b>	<ul style="list-style-type: none"> <li>- check the power cable connections.</li> <li>- check the motor.</li> <li>- check the CT.</li> </ul> <p>The following applies additionally for CU31x and CUA31:            - check the cables and contacts of the brake connection (a wire is possibly broken).            See also: p0287 (Ground fault monitoring thresholds)</p>

---

**F30022**      **Power unit: Monitoring U<sub>ce</sub>**

**Reaction:**      OFF2

**Acknowledge:**    POWER ON

**Cause:**          In the power unit, the monitoring of the collector-emitter voltage (U<sub>ce</sub>) of the semiconductor has responded.  
Possible causes:  
- short-circuit at the Motor Module output.  
- defective semiconductor in the power unit.  
Fault value (r0949, interpret binary):  
Bit 0: Short-circuit in phase U  
Bit 1: Short circuit in phase V  
Bit 2: Short-circuit in phase W  
Bit 3: Light transmitter enable defective  
Bit 4: U<sub>ce</sub> group fault signal interrupted  
See also: r0949 (Fault value)

**Remedy:**        - check the power cable connections.  
- select the defective semiconductor and replace.

---

**F30025**      **Power unit: Chip overtemperature**

**Reaction:**      OFF2

**Acknowledge:**    IMMEDIATELY

**Cause:**          Chip temperature of the semiconductor has exceeded the permissible limit value.  
- the permissible load duty cycle was not maintained.  
- insufficient cooling, fan failure.  
- overload  
- ambient temperature too high.  
- pulse frequency too high.  
Fault value (r0949):  
Temperature difference between the heatsink and chip [1 Bit = 0.01 °C].

**Remedy:**        - adapt the load duty cycle.  
- check whether the fan is running.  
- check the fan elements  
- check whether the ambient temperature is in the permissible range.  
- check the motor load.  
- reduce the pulse frequency if this is higher than the rated pulse frequency.

Notice:  
This fault can only be acknowledged after this alarm threshold for alarm A05001 has been fallen below.  
See also: r0037 (Power unit temperatures)

---

**F30027**      **Power unit: Precharging DC link time monitoring**

**Reaction:**      OFF2

**Acknowledge:**    IMMEDIATELY

**Cause:**          The power unit DC link was not able to be pre-charged within the expected time.  
- line supply voltage too low.  
- line supply phase fault.  
- short-circuit or ground fault in the DC link.  
- pre-charging circuit defective.  
Fault value (r0949):  
Missing internal enable signals, power unit (lower 16 bit):  
(Inverted bit-coded notation FFFF hex -> all internal enable signals available)  
Bit 0: Power supply of the IGBT gating shut down  
Bit 1: Reserved  
Bit 2: Reserved  
Bit 3: Ground fault detected  
Bit 4: Peak current intervention  
Bit 5: I<sub>2t</sub> exceeded  
Bit 6: Thermal model overtemperature calculated  
Bit 7: (heatsink, gating module, power unit) overtemperature measured  
Bit 8: Reserved  
Bit 9: Overvoltage detected

Bit 10: Power unit has completed pre-charging, ready for pulse enable  
 Bit 11: SH terminal missing  
 Bit 12: Overcurrent detected  
 Bit 13: Armature short-circuit active  
 Bit 14: DRIVE-CLiQ fault active  
 Bit 15: Uce fault detected, transistor de-saturated due to overcurrent/circuit-circuit  
 Status, power unit (upper 16 bit, hexadecimal number):  
 0: Fault status (wait for OFF and fault acknowledgment)  
 1: Restart inhibit (wait for OFF)  
 2: Overvoltage condition detected -> change into the fault state  
 3: Undervoltage condition detected -> change into the fault state  
 4: Wait for bypass contactor to open -> change into the fault state  
 5: Wait for bypass contactor to open -> change into restart inhibit  
 6: Commissioning  
 7: Ready for pre-charging  
 8: Pre-charging started, DC link voltage lower than the minimum switch-on voltage  
 9: Pre-charging, DC link voltage end of pre-charging still not detected  
 10: Wait for the end of the de-bounce time of the main contactor after pre-charging has been completed  
 11: Pre-charging completed, ready for pulse enable  
 12: It was detected that the SH terminal was energized at the power unit  
 See also: p0210 (Drive unit line supply voltage)

**Remedy:**

- check the line supply voltage
- check the line supply.

Power unit:  
 See also: p0210 (Drive unit line supply voltage)

---

**A30031 Power unit: Hardware current limiting, phase U**

**Reaction:** NONE

**Acknowledge:** NONE

**Cause:** Hardware current limit for phase U responded. The pulsing in this phase is inhibited for one pulse period.

- closed-loop control is incorrectly parameterized.
- fault in the motor or in the power cables.
- the power cables exceed the maximum permissible length.
- motor load too high
- power unit defective.

**Remedy:**

- check the motor data.
- check the motor circuit configuration (star-delta).
- check the motor load.
- check the power cable connections.
- check the power cables for short-circuit or ground fault.
- check the length of the power cables.

---

**A30032 Power unit: Hardware current limiting, phase V**

**Reaction:** NONE

**Acknowledge:** NONE

**Cause:** Hardware current limit for phase V responded. The pulsing in this phase is inhibited for one pulse period.

- closed-loop control is incorrectly parameterized.
- fault in the motor or in the power cables.
- the power cables exceed the maximum permissible length.
- motor load too high
- power unit defective.

**Remedy:**

- check the motor data.
- check the motor circuit configuration (star-delta).
- check the motor load.
- check the power cable connections.
- check the power cables for short-circuit or ground fault.
- check the length of the power cables.

---

<b>A30033</b>	<b>Power unit: Hardware current limiting, phase W</b>
<b>Reaction:</b>	NONE
<b>Acknowledge:</b>	NONE
<b>Cause:</b>	Hardware current limit for phase W responded. The pulsing in this phase is inhibited for one pulse period. <ul style="list-style-type: none"> <li>- closed-loop control is incorrectly parameterized.</li> <li>- fault in the motor or in the power cables.</li> <li>- the power cables exceed the maximum permissible length.</li> <li>- motor load too high</li> <li>- power unit defective.</li> </ul>
<b>Remedy:</b>	<ul style="list-style-type: none"> <li>- check the motor data.</li> <li>- check the motor circuit configuration (star-delta).</li> <li>- check the motor load.</li> <li>- check the power cable connections.</li> <li>- check the power cables for short-circuit or ground fault.</li> <li>- check the length of the power cables.</li> </ul>

---

<b>F30035</b>	<b>Power unit: Air intake overtemperature</b>
<b>Reaction:</b>	OFF1 (OFF2)
<b>Acknowledge:</b>	IMMEDIATELY
<b>Cause:</b>	Power unit air intake temperature has exceeded the permissible limit value. For air-cooled power units, the limit is at 55 degrees Celsius. <ul style="list-style-type: none"> <li>- ambient temperature too high.</li> <li>- insufficient cooling, fan failure</li> </ul> Fault value (r0949): Temperature [1 bit = 0.01 °C].
<b>Remedy:</b>	<ul style="list-style-type: none"> <li>- check whether the fan is running.</li> <li>- check the fan elements</li> <li>- check whether the ambient temperature is in the permissible range.</li> </ul> Notice: This fault can only be acknowledged after this alarm threshold for alarm A05002 has been fallen below.

---

<b>F30036</b>	<b>Power unit: Electronics board overtemperature</b>
<b>Reaction:</b>	OFF1 (OFF2)
<b>Acknowledge:</b>	IMMEDIATELY
<b>Cause:</b>	Power unit temperature in the module slot of the drive converter has exceeded the permissible limit value. <ul style="list-style-type: none"> <li>- insufficient cooling, fan failure.</li> <li>- overload</li> <li>- ambient temperature too high.</li> </ul> Fault value (r0949): Temperature [1 bit = 0.01 °C].
<b>Remedy:</b>	<ul style="list-style-type: none"> <li>- check whether the fan is running.</li> <li>- check the fan elements</li> <li>- check whether the ambient temperature is in the permissible range.</li> </ul> Notice: This fault can only be acknowledged after this alarm threshold for alarm A05003 has been fallen below.

---

<b>F30037</b>	<b>Power unit: Rectifier overtemperature</b>
<b>Reaction:</b>	OFF2
<b>Acknowledge:</b>	IMMEDIATELY
<b>Cause:</b>	Power unit rectifier temperature has exceeded the permissible limit value. <ul style="list-style-type: none"> <li>- insufficient cooling, fan failure.</li> <li>- overload</li> <li>- ambient temperature too high.</li> <li>- line supply phase failure.</li> </ul> Fault value (r0949): Temperature [1 bit = 0.01 °C].

**Remedy:**

- check whether the fan is running.
- check the fan elements
- check whether the ambient temperature is in the permissible range.
- check the motor load.
- check the line supply phases.

Notice:  
This fault can only be acknowledged after this alarm threshold for alarm A05004 has been fallen below.

---

**F30040 Power unit: Undervolt 24 V**

**Reaction:** OFF2

**Acknowledge:** POWER ON

**Cause:** Failure of the 24 V power supply for the power unit.  
- the 16 V threshold was fallen below for longer than 3 ms.  
Fault value (r0949):  
24 V voltage [1 bit = 0.1 V].

**Remedy:** Check the 24 V DC voltage supply to power unit.

---

**A30041 (F) Power unit: Undervoltage 24 V alarm**

**Reaction:** NONE

**Acknowledge:** NONE

**Cause:** 24 V power supply fault for the power unit.  
- the 16 V threshold was fallen below.  
Fault value (r0949):  
24 V voltage [1 bit = 0.1 V].

**Remedy:** Check the 24 V DC voltage supply to power unit.

Reaction upon F: A\_INFEED: NONE (OFF1, OFF2)  
SERVO: NONE (OFF1, OFF2, OFF3)  
VECTOR: NONE (OFF1, OFF2, OFF3)

Acknowledge upon F: IMMEDIATELY (POWER ON)

---

**A30042 Power unit: Fan operating time reached or exceeded**

**Reaction:** NONE

**Acknowledge:** NONE

**Cause:** The maximum operating time of the fan in the power unit is set in p0252.  
This message indicates the following:  
Fault value (r0949, decimal):  
0: The maximum fan operating time is 500 hours.  
1: The maximum fan operating time has been exceeded.

**Remedy:** Replace the fan in the power unit and reset the operating hours counter to 0 (p0251 = 0).  
See also: p0251 (Operating hours counter, power unit fan), p0252 (Maximum operating time, power unit fan)

---

**F30043 Power unit: Overvolt 24 V**

**Reaction:** OFF2

**Acknowledge:** POWER ON

**Cause:** The following applies for CU31x:  
Overvoltage of the 24 V power supply for the power unit.  
- the 31.5 V threshold was exceeded for more than 3 ms.  
Fault value (r0949):  
24 V voltage [1 bit = 0.1 V].

**Remedy:** Check the 24 V DC voltage supply to power unit.



---

**A30044 (F) Power unit: Overvoltage 24 V alarm**

**Reaction:** NONE  
**Acknowledge:** NONE  
**Cause:** The following applies for CU31x:  
 24 V power supply fault for the power unit.  
 - the 32.0 V threshold was exceeded.  
 Fault value (r0949):  
 24 V voltage [1 bit = 0.1 V].  
**Remedy:** Check the 24 V DC voltage supply to power unit.  
 Reaction upon F: A\_INFEED: NONE (OFF1, OFF2)  
 SERVO: NONE (OFF1, OFF2, OFF3)  
 VECTOR: NONE (OFF1, OFF2, OFF3)  
 Acknowledge upon F: IMMEDIATELY (POWER ON)

---

**F30045 Power unit: Supply undervoltage**

**Reaction:** OFF2  
**Acknowledge:** POWER ON  
**Cause:** The following applies for CU31x:  
 Power supply fault in the power unit.  
 - the voltage monitoring on the DAC board signals an undervoltage fault on the module.  
**Remedy:** Check the 24 V DC power supply for the power unit and if required replace the module.

---

**A30046 (F) Power unit: Undervoltage, alarm**

**Reaction:** NONE  
**Acknowledge:** NONE  
**Cause:** Before the last new start, a problem occurred at the power unit power supply.  
 - the voltage monitoring in the internal FPGA of the PSA signals an undervoltage fault on the module.  
 Fault value (r0949):  
 Register value of the voltage fault register.  
**Remedy:** Check the 24 V DC power supply for the power unit and if required replace the module.  
 Reaction upon F: A\_INFEED: NONE (OFF1, OFF2)  
 SERVO: NONE (OFF1, OFF2, OFF3)  
 VECTOR: NONE (OFF1, OFF2, OFF3)  
 Acknowledge upon F: IMMEDIATELY (POWER ON)

---

**F30047 Cooling system: Cooling medium flow rate too low**

**Reaction:** OFF2  
**Acknowledge:** IMMEDIATELY  
**Cause:** Cooling system: Fault - flow rate has fallen below the fault value  
**Remedy:**

---

**F30050 Power unit: Supply overvoltage**

**Reaction:** OFF2  
**Acknowledge:** POWER ON  
**Cause:** The following applies for CU31x and CUA31:  
 - the voltage monitoring on the DAC board signals an overvoltage fault on the module.  
**Remedy:** Check the 24 V DC power supply of the CU and if required replace the module.

<b>F30052</b>	<b>EEPROM data error</b>
<b>Reaction:</b>	NONE
<b>Acknowledge:</b>	POWER ON
<b>Cause:</b>	EEPROM data error of the power unit module. Fault value (r0949): 0: The EEPROM data read-in from the power unit module is inconsistent. 1: EEPROM data is not compatible to the firmware of the power unit application.
<b>Remedy:</b>	Fault value (r0949): 0: Replace the power unit module or update the EEPROM data. 1: The following applies for CU31x and CUA31: Update the firmware \SIEMENS\SINAMICS\CODE\SAC\cu31xi.ufw (cua31.ufw)
<b>F30070</b>	<b>The power unit does not support the requested cycle.</b>
<b>Reaction:</b>	OFF2
<b>Acknowledge:</b>	IMMEDIATELY
<b>Cause:</b>	The following applies for CU31x and CUA31: A cycle is requested that is not supported by the power unit. Fault value (r0949): The following applies for CU31x and CUA31: 0: The current control cycle is not supported. 1: The DriveCliQ cycle is not supported. 2: Internal timing problem (clearance between RX and TX instants too low) 3: Internal timing problem (TX instant too early)
<b>Remedy:</b>	The following applies for CU31x and CUA31: The power unit only supports the following cycles: 62.5us , 125us, 250us and 500us Fault value (r0949): The following applies for CU31x and CUA31: 0: Set a permitted current control cycle. 1: Set a permitted DriveCliQ cycle. 2/3: Contact the manufacturer (there is possibly an incompatible firmware release)
<b>F30071</b>	<b>The power unit is no longer receiving new actual values.</b>
<b>Reaction:</b>	OFF2
<b>Acknowledge:</b>	IMMEDIATELY
<b>Cause:</b>	The following applies for CU31x and CUA31: More than one actual value telegram from the power unit has failed.
<b>Remedy:</b>	The following applies for CU31x and CUA31: Check the interface (adjustment and locking) to the power unit.
<b>F30072</b>	<b>Setpoints are no longer being transferred to the power unit.</b>
<b>Reaction:</b>	OFF2
<b>Acknowledge:</b>	IMMEDIATELY
<b>Cause:</b>	The following applies for CU31x and CUA31: More than one setpoint telegram was not able to be transferred to the power unit.
<b>Remedy:</b>	The following applies for CU31x and CUA31: Check the interface (adjustment and locking) to the power unit.
<b>A30073 (N)</b>	<b>The actual value/setpoint conditioning is no longer in synchronism with DriveCliQ.</b>
<b>Reaction:</b>	NONE
<b>Acknowledge:</b>	NONE
<b>Cause:</b>	The following applies for CU31x and CUA31: Communications to the power unit is no longer in synchronism with DriveCliQ.
<b>Remedy:</b>	The following applies for CU31x and CUA31: Wait until synchronization is re-established.
Reaction upon N:	NONE
Acknowledge upon N:	NONE

<b>F30074</b>	<b>Communications error to the power unit</b>
<b>Reaction:</b>	NONE
<b>Acknowledge:</b>	POWER ON
<b>Cause:</b>	Communications is not possible to the power unit via the plug contact.
<b>Remedy:</b>	The following applies for CU31x and CUA31: Either replace the CU board or the power unit. You must check which of the two components must be replaced by replacing one and then the other component; if neither are available then both components must be returned.
<b>F30105</b>	<b>LT: Actual value sensing fault</b>
<b>Reaction:</b>	OFF2
<b>Acknowledge:</b>	IMMEDIATELY
<b>Cause:</b>	At least one incorrect actual value channel was detected on the Power Stack Adapter (PSA). The incorrect actual value channels are displayed in the following diagnostic parameters.
<b>Remedy:</b>	Evaluate the diagnostic parameters. If the actual value channel is incorrect, check the components and if required, replace.
<b>F30600</b>	<b>SI MM: STOP A initiated</b>
<b>Reaction:</b>	OFF2
<b>Acknowledge:</b>	IMMEDIATELY (POWER ON)
<b>Cause:</b>	The drive-based "Safety Integrated" function in the Motor Module (MM) has detected a fault and initiated STOP A (pulse cancellation via the safety shutdown path of the Motor Module). - forced checking procedure of the safety shutdown path of the Motor Module unsuccessful. - subsequent response to fault F30611 (defect in a monitoring channel). Fault value (r0949, decimal): 0: Stop request from the Control Unit. 1005: Pulses cancelled although SH not selected and there is not internal STOP A present. 1010: Pulses enabled although SH is selected or an internal STOP A is present. 9999: Subsequent response to fault F30611.
<b>Remedy:</b>	- select safe standstill and then de-select again. - replace the Motor Module involved. Re fault value = 9999: - carry-out diagnostics for fault F30611. Note: CU: Control Unit MM: Motor Module SH: Safe standstill SI: Safety Integrated
<b>F30611</b>	<b>SI MM: Defect in a monitoring channel".</b>
<b>Reaction:</b>	A_INFEED: NONE (OFF1, OFF2) SERVO: NONE (OFF1, OFF2, OFF3) VECTOR: NONE (OFF1, OFF2, OFF3)
<b>Acknowledge:</b>	IMMEDIATELY (POWER ON)
<b>Cause:</b>	The drive-based "Safety Integrated" function in the Motor Module (MM) has detected a fault in the crosswise data comparison between the Control Unit (CU) and MM and initiated a STOP F. As a result of this fault, after the parameterized transition has expired (p9858), fault F30600 is output (SI MM: STOP A initiated). Fault value (r0949, decimal): 0: Stop request from the Control Unit. 1 to 999: Number of the crosswise compared data that resulted in this fault. 1: SI monitoring clock cycle (r9780, r9880). 2: SI enable safety functions (p9601, p9801). 3: SI SGE changeover tolerance time (p9650, p9850). 4: SI transition period STOP F to STOP A (p9658, p9858). 5: SI enable Safe Brake Control (p9602, p9802). 6: SI motion enable, safety-relevant functions (p9501, internal value). This number is also displayed in r9895. 7: SI pulse cancellation delay time for Safe Stop 1 (p9652, p9852).

1000: Watchdog timer has expired. Within the time of approx. 5 \* p9850 too many switching operations have occurred at the safety-related inputs of the Control Unit.  
 1001, 1002: Initialization error, change timer / check timer.  
 2000: Status of the SH terminals on the Control Unit and Motor Module are different.  
 2001: Feedback signal for safe pulse cancellation on the Control Unit and Motor Module are different.  
 2002: Status of the delay timer SS1 on the Control Unit and Motor Module are different.

**Remedy:**

Re fault value = 1 to 999:  
 - check the crosswise compared data that resulted in a STOP F.  
 - carry-out a POWER ON (power off/on) for all components.  
 - upgrade the Motor Module software.  
 - upgrade the Control Unit software.  
 Re fault value = 1000:  
 - check the wiring of the safety-relevant inputs (SGE) on the Control Unit (contact problems).  
 Re fault value = 1001, 1002:  
 - carry-out a POWER ON (power off/on) for all components.  
 - upgrade the Motor Module software.  
 - upgrade the Control Unit software.  
 Re fault value = 2000, 2001, 2002:  
 - check the tolerance time SGE changeover and if required, increase the value (p9650/p9850, p9652/p9852).  
 - check the wiring of the safety-relevant inputs (SGE) (contact problems).  
 - replace the Motor Module involved.

**Note:**

CU: Control Unit  
 MM: Motor Module  
 SGE: Safety-relevant input  
 SH: Safe standstill  
 SI: Safety Integrated  
 SS1: Safe Stop 1 (corresponds to Stop Category 1 acc. to EN60204)

---

**N30620 (F, A) SI MM: Safe standstill active**

**Reaction:** NONE  
**Acknowledge:** NONE  
**Cause:** The "safe standstill" function was selected on the Motor Module (MM) and is active.  
**Note:**  
 This message does not result in a safety stop response.  
**Remedy:** None necessary.  
**Note:**  
 MM: Motor Module  
 SI: Safety Integrated  
 Reaction upon F: OFF2  
 Acknowledge upon F: IMMEDIATELY (POWER ON)  
 Reaction upon A: NONE  
 Acknowledge upon A: NONE

---

**N30621 (F, A) SI MM: Safe Stop 1 active**

**Reaction:** NONE  
**Acknowledge:** NONE  
**Cause:** The "Safe Stop 1" function (SS1) was selected on the Motor Module (MM) and is active.  
**Note:**  
 This message does not result in a safety stop response.  
**Remedy:** None necessary.  
**Note:**  
 MM: Motor Module  
 SI: Safety Integrated  
 SS1: Safe Stop 1 (corresponds to Stop Category 1 acc. to EN60204)

Reaction upon F: A\_INFEED: OFF2  
 SERVO: OFF3  
 VECTOR: OFF3

Acknowledge upon F: IMMEDIATELY (POWER ON)

Reaction upon A: NONE

Acknowledge upon A: NONE

**F30625 SI MM: Sign-of-life error in safety data**

**Reaction:** OFF2

**Acknowledge:** IMMEDIATELY (POWER ON)

**Cause:** The drive-based "Safety Integrated" function on the Motor Module (MM) has detected an error in the sign-of-life of the safety data between the Control Unit (CU) and MM and initiated a STOP A.  
 - there is either a DRIVE-CLiQ communications error or communications have failed.  
 - a time slice overflow of the safety software has occurred.  
 Fault value (r0949, decimal):  
 Only for internal Siemens troubleshooting.

**Remedy:**

- select safe standstill and then de-select again.
- carry-out a POWER ON (power off/on) for all components.
- check whether there is a DRIVE-CLiQ communications error between the Control Unit and the Motor Module involved and if required, carry-out a diagnostics routine for the faults identified.
- de-select all drive functions that are not absolutely necessary.
- reduce the number of drives.
- check the electrical cabinet design and cable routing for EMC compliance

Note:  
 CU: Control Unit  
 MM: Motor Module  
 SI: Safety Integrated

**F30630 SI MM: Braking signal error**

**Reaction:** OFF2

**Acknowledge:** IMMEDIATELY (POWER ON)

**Cause:** The drive-based "Safety Integrated" function on the Motor Module (MM) has detected a braking signal error and initiated a STOP A.  
 - no motor holding brake connected.  
 - the motor holding brake control on the Motor Module or the Control Unit is faulty.  
 - a DRIVE-CLiQ communications error has occurred between the Control Unit and the Motor Module.  
 Fault value (r0949, decimal):  
 10: No brake connected or fault in the Motor Module brake control circuit ("open brake" operation).  
 30: Short-circuit in the brake winding or fault in the Motor Module brake control circuit ("close brake" operation).  
 40: Defect in the brake control circuit of the Motor Module ("brake closed" state).  
 60, 70: Fault in the braking signal of the Control Unit or communications fault between the Control Unit and Motor Module (braking signal).

**Remedy:**

- select safe standstill and then de-select again.
- check the motor holding brake connection.
- check the function of the motor holding brake.
- check whether there is a DRIVE-CLiQ communications error between the Control Unit and the Motor Module involved and if required, carry-out a diagnostics routine for the faults identified.
- check the electrical cabinet design and cable routing for EMC compliance
- replace the Motor Module involved.

Operation with Safe Brake Module:

- check the Safe Brake Modules connection.
- replace the Safe Brake Module. Note:

CU: Control Unit  
 MM: Motor Module  
 SI: Safety Integrated

<b>F30640</b>	<b>SI MM: Fault in the control shutdown path</b>
<b>Reaction:</b>	OFF2
<b>Acknowledge:</b>	IMMEDIATELY (POWER ON)
<b>Cause:</b>	The Motor Module has detected a communications error with the higher-level control to transfer the shutdown information. Note: This fault results in a STOP A that can be acknowledged. Fault value (r0949, decimal): Only for internal Siemens troubleshooting.
<b>Remedy:</b>	- check the PROFIsafe address in the higher-level control and Motor Modules. - carry-out a POWER ON for all components. - upgrade the Motor Module software. Note: MM: Motor Module SI: Safety Integrated See also: p9810 (SI PROFIsafe address (Motor Module))
<b>F30649</b>	<b>SI MM: Internal software error</b>
<b>Reaction:</b>	OFF2
<b>Acknowledge:</b>	IMMEDIATELY (POWER ON)
<b>Cause:</b>	An internal error in the Safety Integrated software on the Motor Module has occurred. Note: This fault results in a STOP A that cannot be acknowledged. Fault value (r0949, interpret hexadecimal): Only for internal Siemens troubleshooting.
<b>Remedy:</b>	- carry-out a POWER ON (power off/on) for all components. - re-commission the Safety Integrated function and carry-out a POWER ON. - upgrade the Motor Module software. - contact the Hotline. - replace the Motor Module. Note: MM: Motor Module SI: Safety Integrated
<b>F30650</b>	<b>SI MM: Acceptance test required</b>
<b>Reaction:</b>	OFF2
<b>Acknowledge:</b>	IMMEDIATELY (POWER ON)
<b>Cause:</b>	The "Safety Integrated" function on the Motor Module requires an acceptance test. Note: This fault results in a STOP A that can be acknowledged. Fault value (r0949, decimal): 130: No safety parameters available for the Motor Module. 1000: Reference and actual checksum in the Motor Module are not identical (booting). - at least one checksum-checked piece of data is defective. 2000: Reference and actual checksum on the Motor Module are not identical (commissioning mode). - reference checksum incorrectly entered into the Motor Module (p9899 not equal to r9898). 2003: Acceptance test is required as a safety parameter has been changed. 9999: Subsequent response of another safety-related fault, which occurred when booting and requires an acceptance test.
<b>Remedy:</b>	Re fault value = 130: - carry-out safety commissioning routine. Re fault value = 1000: - again carry-out safety commissioning routine. - replace the CompactFlash card. Re fault value = 2000: - check the safety parameters in the Motor Module and adapt the reference checksum (p9899).

Re fault value = 2003:  
 - carry-out an acceptance test.  
 Re fault value = 9999:  
 - carry-out diagnostics for the other safety-related fault that is present.  
 Note:  
 MM: Motor Module  
 SI: Safety Integrated  
 See also: p9799 (SI reference checksum SI parameters (Control Unit)), p9899 (SI reference checksum SI parameters (Motor Module))

---

**F30651**      **SI MM: Synchronization with Control Unit unsuccessful**  
**Reaction:**      OFF2  
**Acknowledge:**      IMMEDIATELY (POWER ON)  
**Cause:**      The drive-based "Safety Integrated" function is requesting synchronization of the safety time slices on the Control Unit and Motor Module. This synchronization routine was not successful.  
 Note:  
 This fault results in a STOP A that cannot be acknowledged.  
 Fault value (r0949, decimal):  
 Only for internal Siemens troubleshooting.  
**Remedy:**      - carry-out a POWER ON (power off/on) for all components.  
                      - upgrade the Motor Module software.  
                      - upgrade the Control Unit software.  
 Note:  
 MM: Motor Module  
 SI: Safety Integrated

---

**F30652**      **SI MM: Illegal monitoring clock cycle**  
**Reaction:**      OFF2  
**Acknowledge:**      IMMEDIATELY (POWER ON)  
**Cause:**      The Safety Integrated monitoring clock cycle cannot be maintained due to the communication conditions requested in the system.  
 Note:  
 This fault results in a STOP A that cannot be acknowledged.  
 Fault value (r0949, decimal):  
 Only for internal Siemens troubleshooting.  
**Remedy:**      Upgrade the Motor Module software.  
 Note:  
 MM: Motor Module  
 SI: Safety Integrated

---

**F30655**      **SI MM: Align monitoring functions**  
**Reaction:**      OFF2  
**Acknowledge:**      IMMEDIATELY (POWER ON)  
**Cause:**      An error has occurred when aligning the Safety Integrated monitoring functions on the Control Unit (CU) and Motor Module (MM). Control unit and Motor Module were not able to determine a common set of supported SI monitoring functions.  
                      - there is either a DRIVE-CLIQ communications error or communications have failed.  
                      - Safety Integrated software releases on the Control Unit and Motor Module are not compatible with one another.  
 Note:  
 This fault results in a STOP A that cannot be acknowledged.  
 Fault value (r0949, interpret hexadecimal):  
 Only for internal Siemens troubleshooting.  
**Remedy:**      - carry-out a POWER ON (power off/on) for all components.  
                      - upgrade the Motor Module software.  
                      - upgrade the Control Unit software.  
                      - check the electrical cabinet design and cable routing for EMC compliance  
 Note:  
 CU: Control Unit  
 MM: Motor Module  
 SI: Safety Integrated

<b>F30656</b>	<b>SI MM: Motor Module parameter error</b>
<b>Reaction:</b>	OFF2
<b>Acknowledge:</b>	IMMEDIATELY (POWER ON)
<b>Cause:</b>	When accessing the Safety Integrated parameters for the Motor Module (MM) on the CompactFlash card, an error has occurred. Note: This fault results in a STOP A that can be acknowledged. Fault value (r0949, decimal): 129: Safety parameters for the Motor Module corrupted. 131: Internal software error on the Control Unit. 255: Internal Motor Module software error.
<b>Remedy:</b>	- re-commission the safety functions. - upgrade the Control Unit software. - upgrade the Motor Module software. - replace the CompactFlash card. Note: MM: Motor Module SI: Safety Integrated
<b>F30659</b>	<b>SI MM: Write request for parameter rejected</b>
<b>Reaction:</b>	OFF2
<b>Acknowledge:</b>	IMMEDIATELY (POWER ON)
<b>Cause:</b>	The write request for one or several Safety Integrated parameters on the Motor Module (MM) was rejected. Note: This fault does not result in a safety stop response. Fault value (r0949, decimal): 10: An attempt was made to enable the SH function although this cannot be supported. 11: An attempt was made to enable the SBC function although this cannot be supported. 13: An attempt was made to enable the SS1 function although this cannot be supported. 14: An attempt was made to enable the safe motion monitoring function with the higher-level control, although this cannot be supported. See also: r9771 (SI common functions (Control Unit)), r9871 (SI common functions (Motor Module))
<b>Remedy:</b>	Re fault value = 10, 11: - check whether there are faults in the safety function alignment between the Control Unit and the Motor Module involved (F01655, F30655) and if required, carry-out diagnostics for the faults involved. - use a Motor Module that supports the function safe standstill or Safe Brake Control. - upgrade the Motor Module software. - upgrade the Control Unit software. Note: MM: Motor Module SBC: Safe Brake Control SH: Safe standstill SI: Safety Integrated, SS1: Safe Stop 1 (corresponds to Stop Category 1 acc. to EN60204)
<b>F30801</b>	<b>Power unit DRIVE-CLiQ: Sign-of-life missing</b>
<b>Reaction:</b>	OFF2
<b>Acknowledge:</b>	IMMEDIATELY
<b>Cause:</b>	A DRIVE-CLiQ communications error has occurred between the Control Unit and the power unit involved. Fault value (r0949, interpret hexadecimal): 0A: The sign-of-life bit in the receive telegram is not set.
<b>Remedy:</b>	- check the electrical cabinet design and cable routing for EMC compliance. - replace the component involved. See also: p9916 (DRIVE-CLiQ data transfer error, shutdown threshold, slave)
<b>F30802</b>	<b>Power unit: Time slice overflow</b>
<b>Reaction:</b>	OFF2
<b>Acknowledge:</b>	IMMEDIATELY
<b>Cause:</b>	Time slice overflow.
<b>Remedy:</b>	



<b>A30804 (F)</b>	<b>Power unit: CRC</b>
<b>Reaction:</b>	NONE
<b>Acknowledge:</b>	NONE
<b>Cause:</b>	CRC error actuator
<b>Remedy:</b>	
Reaction upon F:	A_INFEED: OFF2 (OFF1) SERVO: OFF2 (OFF1, OFF3) VECTOR: OFF2 (OFF1, OFF3)
Acknowledge upon F:	IMMEDIATELY
<b>F30805</b>	<b>Power unit: EPROM checksum error</b>
<b>Reaction:</b>	OFF2
<b>Acknowledge:</b>	IMMEDIATELY
<b>Cause:</b>	Internal parameter data is corrupted. Fault value (r0949, interpret hexadecimal): 01: EEPROM access error. 02: Too many blocks in the EEPROM.
<b>Remedy:</b>	Replace the module.
<b>F30809</b>	<b>Power unit: Switching information not valid</b>
<b>Reaction:</b>	OFF2
<b>Acknowledge:</b>	IMMEDIATELY
<b>Cause:</b>	For 3P gating unit: The last switching status word in the setpoint telegram is identified by the end ID. Such an end ID was not found.
<b>Remedy:</b>	
<b>A30810 (F)</b>	<b>Power unit: Watchdog timer</b>
<b>Reaction:</b>	NONE
<b>Acknowledge:</b>	NONE
<b>Cause:</b>	When booting it was detected that the cause of the previous reset was an SAC watchdog timer overflow.
<b>Remedy:</b>	
Reaction upon F:	NONE (OFF2)
Acknowledge upon F:	IMMEDIATELY
<b>F30820</b>	<b>Power unit DRIVE-CLiQ: Telegram error</b>
<b>Reaction:</b>	OFF2
<b>Acknowledge:</b>	IMMEDIATELY
<b>Cause:</b>	A DRIVE-CLiQ communications error has occurred between the Control Unit and the power unit involved. Fault value (r0949, interpret hexadecimal): 01: CRC error. 02: Telegram is shorter than specified in the length byte or in the receive list. 03: Telegram is longer than specified in the length byte or in the receive list. 04: The length of the receive telegram does not match the receive list. 05: The type of the receive telegram does not match the receive list. 06: The address of the power unit in the telegram and in the receive list do not match. 07: Power unit expects a SYNC telegram, but the receive telegram is not a SYNC telegram. 08: Power unit does not expect a SYNC telegram, but the receive telegram is a SYNC telegram. 09: The error bit in the receive telegram is set. 10: The receive telegram is too early.
<b>Remedy:</b>	- carry-out a POWER ON. - check the electrical cabinet design and cable routing for EMC compliance. - check the DRIVE-CLiQ wiring (interrupted cable, contacts, ...). See also: p9916 (DRIVE-CLiQ data transfer error, shutdown threshold, slave)

<b>F30835</b>	<b>Power unit DRIVE-CLiQ: Cyclic data transfer error</b>
<b>Reaction:</b>	OFF2
<b>Acknowledge:</b>	IMMEDIATELY
<b>Cause:</b>	A DRIVE-CLiQ communications error has occurred between the Control Unit and the power unit involved. The nodes do not send and receive in synchronism. Fault value (r0949, interpret hexadecimal): 21: The cyclic telegram has not been received. 22: Timeout in the telegram receive list. 40: Timeout in the telegram send list.
<b>Remedy:</b>	- carry-out a POWER ON. - replace the component involved. See also: p9916 (DRIVE-CLiQ data transfer error, shutdown threshold, slave)
<b>F30836</b>	<b>Power unit DRIVE-CLiQ: Send error for DRIVE-CLiQ data</b>
<b>Reaction:</b>	OFF2
<b>Acknowledge:</b>	IMMEDIATELY
<b>Cause:</b>	A DRIVE-CLiQ communications error has occurred between the Control Unit and the power unit involved. Data were not able to be sent. Fault value (r0949, interpret hexadecimal): 41: Telegram type does not match send list.
<b>Remedy:</b>	Carry-out a POWER ON.
<b>F30837</b>	<b>Power unit DRIVE-CLiQ: Component fault</b>
<b>Reaction:</b>	OFF2
<b>Acknowledge:</b>	IMMEDIATELY
<b>Cause:</b>	Fault detected on the DRIVE-CLiQ component involved. Faulty hardware cannot be excluded. Fault value (r0949, interpret hexadecimal): 20: Error in the telegram header. 23: Receive error: The telegram buffer memory contains an error. 42: Send error: The telegram buffer memory contains an error. 43: Send error: The telegram buffer memory contains an error.
<b>Remedy:</b>	- check the DRIVE-CLiQ wiring (interrupted cable, contacts, ...). - check the electrical cabinet design and cable routing for EMC compliance. - if required, use another DRIVE-CLiQ socket (p9904). - replace the component involved.
<b>F30845</b>	<b>Power unit DRIVE-CLiQ: Cyclic data transfer error</b>
<b>Reaction:</b>	OFF2
<b>Acknowledge:</b>	IMMEDIATELY
<b>Cause:</b>	A DRIVE-CLiQ communications error has occurred between the Control Unit and the power unit involved. Fault value (r0949, interpret hexadecimal): 0B: Synchronization error during alternating cyclic data transfer.
<b>Remedy:</b>	Carry-out a POWER ON. See also: p9916 (DRIVE-CLiQ data transfer error, shutdown threshold, slave)
<b>F30850</b>	<b>Power unit: Internal software error</b>
<b>Reaction:</b>	A_INFEED: OFF1 (NONE, OFF2) SERVO: OFF1 (NONE, OFF2, OFF3) VECTOR: OFF1 (NONE, OFF2, OFF3)
<b>Acknowledge:</b>	POWER ON
<b>Cause:</b>	An internal software error in the power unit has occurred. Fault value (r0949, decimal): Only for internal Siemens troubleshooting.
<b>Remedy:</b>	- replace power unit. - if required, upgrade the firmware in the power unit. - contact the Hotline.

<b>F30851</b>	<b>CU DRIVE-CLiQ: Sign-of-life missing</b>
<b>Reaction:</b>	A_INFEED: OFF2 (NONE, OFF1) SERVO: OFF2 (NONE, OFF1, OFF3) VECTOR: OFF2 (NONE, OFF1, OFF3)
<b>Acknowledge:</b>	IMMEDIATELY
<b>Cause:</b>	A DRIVE-CLiQ communications error has occurred between the Control Unit and the power unit involved. The DRIVE-CLiQ component did not set the sign of life to the Control Unit. Fault value (r0949, interpret hexadecimal): 0A: The sign-of-life bit in the receive telegram is not set.
<b>Remedy:</b>	Upgrade the firmware of the component involved.
<b>F30860</b>	<b>CU DRIVE-CLiQ: Telegram error</b>
<b>Reaction:</b>	OFF2
<b>Acknowledge:</b>	IMMEDIATELY
<b>Cause:</b>	A DRIVE-CLiQ communications error has occurred between the Control Unit and the power unit involved. Fault value (r0949, interpret hexadecimal): 11: CRC error and the receive telegram is too early. 01: CRC error. 12: The telegram is shorter than that specified in the length byte or in the receive list and the receive telegram is too early. 02: Telegram is shorter than specified in the length byte or in the receive list. 13: The telegram is longer than that specified in the length byte or in the receive list and the receive telegram is too early. 03: Telegram is longer than specified in the length byte or in the receive list. 14: The length of the receive telegram does not match the receive list and the receive telegram is too early. 04: The length of the receive telegram does not match the receive list. 15: The type of the receive telegram does not match the receive list and the receive telegram is too early. 05: The type of the receive telegram does not match the receive list. 16: The address of the power unit in the telegram and in the receive list does not match and the receive telegram is too early. 06: The address of the power unit in the telegram and in the receive list do not match. 19: The error bit in the receive telegram is set and the receive telegram is too early. 09: The error bit in the receive telegram is set. 10: The receive telegram is too early.
<b>Remedy:</b>	- carry-out a POWER ON. - check the electrical cabinet design and cable routing for EMC compliance. - check the DRIVE-CLiQ wiring (interrupted cable, contacts, ...). See also: p9915 (DRIVE-CLiQ data transfer error, shutdown threshold, master)
<b>F30885</b>	<b>CU DRIVE-CLiQ: Cyclic data transfer error</b>
<b>Reaction:</b>	OFF2
<b>Acknowledge:</b>	IMMEDIATELY
<b>Cause:</b>	A DRIVE-CLiQ communications error has occurred between the Control Unit and the power unit involved. The nodes do not send and receive in synchronism. Fault value (r0949, interpret hexadecimal): 1A: Sign-of-life bit in the receive telegram not set and the receive telegram is too early. 21: The cyclic telegram has not been received. 22: Timeout in the telegram receive list. 40: Timeout in the telegram send list. 62: Error at the transition to cyclic operation.
<b>Remedy:</b>	- check the power supply voltage of the component involved. - carry-out a POWER ON. - replace the component involved. See also: p9915 (DRIVE-CLiQ data transfer error, shutdown threshold, master)
<b>F30886</b>	<b>CU DRIVE-CLiQ: Error when sending DRIVE-CLiQ data</b>
<b>Reaction:</b>	OFF2
<b>Acknowledge:</b>	IMMEDIATELY

**Cause:** A DRIVE-CLiQ communications error has occurred between the Control Unit and the power unit involved. Data were not able to be sent.  
 Fault value (r0949, interpret hexadecimal):  
 41: Telegram type does not match send list.

**Remedy:** Carry-out a POWER ON.

---

**F30887 CU DRIVE-CLiQ: Component fault**

**Reaction:** OFF2

**Acknowledge:** IMMEDIATELY

**Cause:** Fault detected on the DRIVE-CLiQ component involved. Faulty hardware cannot be excluded.  
 Fault value (r0949, interpret hexadecimal):  
 20: Error in the telegram header.  
 23: Receive error: The telegram buffer memory contains an error.  
 42: Send error: The telegram buffer memory contains an error.  
 43: Send error: The telegram buffer memory contains an error.  
 60: Response received too late during runtime measurement.  
 61: Time taken to exchange characteristic data too long.

**Remedy:**

- check the DRIVE-CLiQ wiring (interrupted cable, contacts, ...).
- check the electrical cabinet design and cable routing for EMC compliance.
- if required, use another DRIVE-CLiQ socket (p9904).
- replace the component involved.

---

**F30895 CU DRIVE-CLiQ: Cyclic data transfer error**

**Reaction:** A\_INFEED: OFF2 (NONE, OFF1)  
 SERVO: OFF2 (DCBRAKE, NONE, OFF1, OFF3, STOP1, STOP2)  
 VECTOR: OFF2 (DCBRAKE, NONE, OFF1, OFF3, STOP1, STOP2)

**Acknowledge:** IMMEDIATELY

**Cause:** A DRIVE-CLiQ communications error has occurred between the Control Unit and the power unit involved.  
 Fault value (r0949, interpret hexadecimal):  
 0B: Synchronization error during alternating cyclic data transfer.

**Remedy:** Carry-out a POWER ON.  
 See also: p9915 (DRIVE-CLiQ data transfer error, shutdown threshold, master)

---

**F30896 CU DRIVE-CLiQ: Inconsistent component characteristics**

**Reaction:** A\_INFEED: OFF2 (NONE, OFF1)  
 SERVO: OFF2 (DCBRAKE, NONE, OFF1, OFF3, STOP1, STOP2)  
 VECTOR: OFF2 (DCBRAKE, NONE, OFF1, OFF3, STOP1, STOP2)

**Acknowledge:** IMMEDIATELY

**Cause:** The properties of the DRIVE-CLiQ component, specified by the fault value, have changed in an incompatible fashion with respect to the properties when booted. One cause can be, e.g. that a DRIVE-CLiQ cable or DRIVE-CLiQ component has been replaced.  
 Fault value (r0949, decimal):  
 Component ID.

**Remedy:**

- when replacing cables, only use cables with the same length as the original cables.
- when replacing components, use the same components and firmware releases.
- carry-out a POWER ON.

---

**F30897 DRIVE-CLiQ: No communication to component**

**Reaction:** A\_INFEED: OFF2 (NONE, OFF1)  
 SERVO: OFF2 (DCBRAKE, ENCODER, NONE, OFF1, OFF3, STOP1, STOP2)  
 VECTOR: OFF2 (DCBRAKE, ENCODER, NONE, OFF1, OFF3, STOP1, STOP2)

**Acknowledge:** IMMEDIATELY (POWER ON)

**Cause:** Communications with the DRIVE-CLiQ component specified by the fault value is not possible.  
 One cause can be, e.g. that a DRIVE-CLiQ cable has been withdrawn.  
 Fault value (r0949, decimal):  
 Component ID.

**Remedy:**

- check the DRIVE-CLiQ connections.
- carry-out a POWER ON.

<b>F30899 (N, A)</b>	<b>Power unit: Unknown fault</b>
<b>Reaction:</b>	A_INFEED: NONE (OFF1, OFF2) SERVO: NONE (DCBRAKE, OFF1, OFF2, OFF3, STOP1, STOP2) VECTOR: NONE (DCBRAKE, OFF1, OFF2, OFF3, STOP1, STOP2)
<b>Acknowledge:</b>	IMMEDIATELY (POWER ON)
<b>Cause:</b>	A fault occurred on the power unit that cannot be interpreted by the Control Unit firmware. This can occur if the firmware on the power unit is more recent than the firmware on the Control Unit. Fault value (r0949, decimal): Fault number. If required, the significance of this new fault can be read about in a more recent description of the Control Unit.
<b>Remedy:</b>	- replace the firmware on the power unit by an older firmware version (r0128). - upgrade the firmware on the Control Unit (r0018).
Reaction upon N:	NONE
Acknowledge upon N:	NONE
Reaction upon A:	NONE
Acknowledge upon A:	NONE
<b>A30903</b>	<b>Power unit: I2C bus</b>
<b>Reaction:</b>	NONE
<b>Acknowledge:</b>	NONE
<b>Cause:</b>	Communications with EPROM not possible. Fault value (r0949, interpret hexadecimal): Only for internal Siemens troubleshooting.
<b>Remedy:</b>	Replace the module.
<b>F30907</b>	<b>Power unit: FPGA configuration unsuccessful</b>
<b>Reaction:</b>	A_INFEED: OFF2 (NONE, OFF1) SERVO: OFF2 (DCBRAKE, NONE, OFF1, OFF3, STOP1, STOP2) VECTOR: OFF2 (DCBRAKE, NONE, OFF1, OFF3, STOP1, STOP2)
<b>Acknowledge:</b>	IMMEDIATELY
<b>Cause:</b>	For the initialization within the power unit, an internal software error has occurred.
<b>Remedy:</b>	- replace power unit. - if required, upgrade the firmware in the power unit. - contact the Hotline.
<b>A30920 (F)</b>	<b>Power unit: Temperature sensor fault</b>
<b>Reaction:</b>	NONE
<b>Acknowledge:</b>	NONE
<b>Cause:</b>	When evaluating the temperature sensor, an error occurred. Alarm value (r2124, decimal): 1: Wire breakage or sensor not connected (KTY: R > 1630 Ohm). 2: Measured resistance too low (PTC: R < 20 Ohm, KTY: R < 50 Ohm).
<b>Remedy:</b>	- check that the sensor is connected correctly. - replace sensor.
Reaction upon F:	A_INFEED: NONE (OFF1, OFF2) SERVO: NONE (DCBRAKE, OFF1, OFF2, OFF3, STOP1, STOP2) VECTOR: NONE (DCBRAKE, OFF1, OFF2, OFF3, STOP1, STOP2)
Acknowledge upon F:	IMMEDIATELY

---

<b>A30999 (F, N)</b>	<b>Power unit: Unknown alarm</b>
<b>Reaction:</b>	NONE
<b>Acknowledge:</b>	NONE
<b>Cause:</b>	An alarm occurred on the power unit that cannot be interpreted by the Control Unit firmware. This can occur if the firmware on the power unit is more recent than the firmware on the Control Unit. Alarm value (r2124, decimal): Alarm number. If required, the significance of this new alarm can be read about in a more recent description of the Control Unit.
<b>Remedy:</b>	- replace the firmware on the power unit by an older firmware version (r0128). - upgrade the firmware on the Control Unit (r0018).
Reaction upon F:	A_INFEED: NONE (OFF1, OFF2) SERVO: NONE (DCBRAKE, OFF1, OFF2, OFF3, STOP1, STOP2) VECTOR: NONE (DCBRAKE, OFF1, OFF2, OFF3, STOP1, STOP2)
Acknowledge upon F:	IMMEDIATELY (POWER ON)
Reaction upon N:	NONE
Acknowledge upon N:	NONE

---

<b>F31100 (N, A)</b>	<b>Encoder 1: Zero mark distance error</b>
<b>Reaction:</b>	A_INFEED: NONE (OFF1, OFF2) SERVO: ENCODER (DCBRAKE, OFF1, OFF2, OFF3, STOP1, STOP2) VECTOR: ENCODER (DCBRAKE, OFF1, OFF2, OFF3, STOP1, STOP2)
<b>Acknowledge:</b>	PULSE INHIBIT
<b>Cause:</b>	The measured zero mark distance does not correspond to the parameterized zero mark distance. For distance-coded encoders, the zero mark distance is determined from zero marks detected pairs. This means that if a zero mark is missing, depending on the pair generation, this cannot result in a fault and also has no effect in the system. The zero mark distance for the zero mark monitoring is set in p0425 (rotary encoder) or p0424 (linear encoder). Fault value (r0949, decimal): Last measured zero mark distance in increments (4 increments = 1 encoder pulse). The sign designates the direction of motion when detecting the zero mark distance. See also: p0491 (Motor encoder fault response ENCODER)
<b>Remedy:</b>	- check that the encoder cables are routed in compliance with EMC. - check the plug connections. . check the encoder type (encoder with equidistant zero marks). - adapt the parameter for the distance between zero marks (p0424, p0425). - replace the encoder or encoder cable.
Reaction upon N:	NONE
Acknowledge upon N:	NONE
Reaction upon A:	NONE
Acknowledge upon A:	NONE

---

<b>F31101 (N, A)</b>	<b>Encoder 1: Zero marked failed</b>
<b>Reaction:</b>	A_INFEED: NONE (OFF1, OFF2) SERVO: ENCODER (DCBRAKE, NONE, OFF1, OFF2, OFF3, STOP1, STOP2) VECTOR: ENCODER (DCBRAKE, NONE, OFF1, OFF2, OFF3, STOP1, STOP2)
<b>Acknowledge:</b>	PULSE INHIBIT
<b>Cause:</b>	The 1.5 x parameterized zero mark distance was exceeded. The zero mark distance for the zero mark monitoring is set in p0425 (rotary encoder) or p0424 (linear encoder). Fault value (r0949, decimal): Number of increments after POWER ON or since the last zero mark that was detected (4 increments = 1 encoder pulse). See also: p0491 (Motor encoder fault response ENCODER)

**Remedy:**

- check that the encoder cables are routed in compliance with EMC.
- check the plug connections.
- check the encoder type (encoder with equidistant zero marks).
- adapt the parameter for the clearance between zero marks (p0425).
- replace the encoder or encoder cable.

Reaction upon N: NONE  
 Acknowledge upon N: NONE  
 Reaction upon A: NONE  
 Acknowledge upon A: NONE

---

**F31110 (N, A) Encoder 1: Serial communications error**

**Reaction:** A\_INFEED: NONE  
 SERVO: ENCODER (DCBRAKE, NONE)  
 VECTOR: ENCODER (DCBRAKE, NONE)

**Acknowledge:** PULSE INHIBIT

**Cause:** Serial communication protocol transfer error between the encoder and evaluation module.  
 Fault value (r0949, interpret binary):  
 Bit 0: Alarm bit in the position protocol.  
 Bit 1: Incorrect quiescent level on the data line.  
 Bit 2: Encoder does not respond (does not supply a start bit within 50 ms).  
 Bit 3: CRC error: The checksum in the protocol from the encoder does not match the data.  
 Bit 4: Encoder acknowledgement error: The encoder incorrectly understood the task (request) or cannot execute it.  
 Bit 5: Internal error in the serial driver: An illegal mode command was requested.  
 Bit 6: Timeout with cyclically reading.  
 Bit 8: Protocol is too long (e.g. > 64 bits).  
 Bit 9: Receive buffer overflow  
 Bit 10: Frame error when reading twice.  
 Bit 11: Parity error.  
 Bit 12: Data line signal level error during the monoflop time.

**Remedy:** Re fault value:  
 Bit 0 = 1: Encoder defective. F31111 may provide additional details.  
 Bit 1 = 1: Incorrect encoder type / replace the encoder or encoder cable.  
 Bit 2 = 1: Incorrect encoder type / replace the encoder or encoder cable.  
 Bit 3 = 1: EMC / connect the cable shield, replace the encoder or encoder cable.  
 Bit 4 = 1: EMC / connect the cable shield, replace the encoder or encoder cable, replace the Sensor Module.  
 Bit 5 = 1: EMC / connect the cable shield, replace the encoder or encoder cable, replace the Sensor Module.  
 Bit 6 = 1: Update the Sensor Module firmware.  
 Bit 8 = 1: Check the parameterization (p0429.2).  
 Bit 9 = 1: EMC / connect the cable shield, replace the encoder or encoder cable, replace the Sensor Module.  
 Bit 10 = 1: Check the parameterization (p0429.2, p0449).  
 Bit 11 = 1: Check the parameterization (p0436).  
 Bit 12 = 1: Check the parameterization (p0429.6).

Reaction upon N: NONE  
 Acknowledge upon N: NONE  
 Reaction upon A: NONE  
 Acknowledge upon A: NONE

**F31111 (N, A) Encoder 1: Absolute encoder EnDat, internal fault/error**

**Reaction:** A\_INFEED: NONE  
 SERVO: ENCODER (DCBRAKE, NONE)  
 VECTOR: ENCODER (DCBRAKE, NONE)

**Acknowledge:** PULSE INHIBIT

**Cause:** The EnDat encoder fault word contains fault bits that have been set.  
 Fault value (r0949, interpret binary):  
 Bit 0: Lighting system failed.  
 Bit 1: Signal amplitude too low.  
 Bit 2: Position value incorrect.  
 Bit 3: Encoder power supply overvoltage condition.  
 Bit 4: Encoder power supply undervoltage condition.  
 Bit 5: Encoder power supply overcurrent condition.  
 Bit 6: The battery must be changed.  
 See also: p0491 (Motor encoder fault response ENCODER)

**Remedy:** Re fault value, bit 0 = 1:  
 Encoder is defective. Replace the encoder, where the motor encoder has a direct DRIVE-CLiQ socket: Replace the motor.  
 Re fault value, bit 1 = 1:  
 Encoder is defective. Replace the encoder, where the motor encoder has a direct DRIVE-CLiQ socket: Replace the motor.  
 Re fault value, bit 2 = 1:  
 Encoder is defective. Replace the encoder, where the motor encoder has a direct DRIVE-CLiQ socket: Replace the motor.  
 Re fault value, bit 3 = 1:  
 5 V power supply voltage fault.  
 When using an SMC: Check the plug-in cable between the encoder and SMC or replace the SMC.  
 When a motor encoder with a direct DRIVE-CLiQ connection is used: Replace the motor.  
 Re fault value, bit 4 = 1:  
 5 V power supply voltage fault.  
 When using an SMC: Check the plug-in cable between the encoder and SMC or replace the SMC.  
 When using a motor with DRIVE-CLiQ: Replace the motor.  
 Re fault value, bit 5 = 1:  
 Encoder is defective. Replace the encoder, where the motor encoder has a direct DRIVE-CLiQ socket: Replace the motor.  
 Re fault value, bit 6 = 1:  
 The battery must be changed - only for encoders with battery back-up.

Reaction upon N: NONE  
 Acknowledge upon N: NONE  
 Reaction upon A: NONE  
 Acknowledge upon A: NONE

**F31112 (N, A) Encoder 1: The error bit is set in the serial protocol**

**Reaction:** A\_INFEED: NONE  
 SERVO: ENCODER (DCBRAKE, NONE)  
 VECTOR: ENCODER (DCBRAKE, NONE)

**Acknowledge:** PULSE INHIBIT

**Cause:** Serial communication protocol transfer error between the encoder and evaluation module SMCxx.  
 Fault value (r0949, interpret binary):

**Remedy:** Re fault value:

Reaction upon N: NONE  
 Acknowledge upon N: NONE  
 Reaction upon A: NONE  
 Acknowledge upon A: NONE



**F31115 (N, A) Encoder 1: Amplitude error track A or B (A<sup>2</sup> + B<sup>2</sup>)**

**Reaction:** A\_INFEED: NONE  
SERVO: ENCODER (DCBRAKE, NONE)  
VECTOR: ENCODER (DCBRAKE, NONE)

**Acknowledge:** PULSE INHIBIT

**Cause:** The amplitude (A<sup>2</sup> + B<sup>2</sup>) does not lie within the tolerance bandwidth (software monitoring function).  
SMC20:  
The nominal signal level of the encoder must lie in the range 375 mV to 600 mV (500 mV -25 % / +20 %).  
On the other hand, the response threshold is < 230 mV (frequency characteristic).  
SMC10:  
The nominal signal level is at 2900 mV (2.0 Vrms). The response threshold is < 1070 mV.  
Fault value (r0949, decimal):  
Low word:  
Signal level, track A (16 bits with sign).  
High word:  
Signal level, track B (16 bits with sign).  
SMC20:  
A signal level of 500 mV peak value corresponds to the numerical value 5333 hex = 21299 dec.  
SMC10:  
A signal level of 2900 mV peak value corresponds to the numerical value 6666 hex = 26214 dec.  
See also: p0491 (Motor encoder fault response ENCODER)

**Remedy:**

- check that the encoder cables are routed in compliance with EMC.
- check the plug connections.
- replace the encoder or encoder cable.
- check the encoder module (e.g. contacts).
- with measuring systems without their own bearing system: Adjust the scanning head and check the bearing system of the measuring wheel.
- for measuring systems with their own bearing system: Ensure that the encoder housing is not subject to any axial force.

Reaction upon N: NONE  
Acknowledge upon N: NONE  
Reaction upon A: NONE  
Acknowledge upon A: NONE

**F31116 (N, A) Encoder 1: Amplitude error, monitoring track A + B**

**Reaction:** A\_INFEED: NONE  
SERVO: ENCODER (DCBRAKE, NONE)  
VECTOR: ENCODER (DCBRAKE, NONE)

**Acknowledge:** IMMEDIATELY

**Cause:** The amplitude of the rectified encoder signals A and B is not within the tolerance bandwidth (hardware monitoring).  
The nominal signal level of the encoder must lie in the range 375 mV to 600 mV (500 mV -25 % / +20 %).  
On the other hand, the hardware response thresholds are at < 176 mV and > 1.35 V.  
Fault value (r0949, decimal):  
Low word: Signal level, track A (16 bits with sign).  
High word: Signal level, track B (16 bits with sign).  
A signal level of 500 mV corresponds to the numerical value 5333 hex = 21299 dec.  
These analog values are not measured at the same time with the hardware fault output.  
See also: p0491 (Motor encoder fault response ENCODER)

**Remedy:**

- check that the encoder cables are routed in compliance with EMC.
- check the plug connections.
- replace the encoder or encoder cable.
- check the encoder module (e.g. contacts).

Reaction upon N: NONE  
Acknowledge upon N: NONE  
Reaction upon A: NONE  
Acknowledge upon A: NONE

---

**F31117 (N, A) Encoder 1: Inversion error, signals A and B and R**

**Reaction:** A\_INFEED: NONE  
SERVO: ENCODER (DCBRAKE, NONE)  
VECTOR: ENCODER (DCBRAKE, NONE)

**Acknowledge:** IMMEDIATELY

**Cause:** For a square-wave signal encoder (TTL. bipolar. double ended) the A\* and B\* and R\* signals are not inverted with respect to signals A and B and R.  
See also: p0491 (Motor encoder fault response ENCODER)

**Remedy:** Check the setting of p0405: p0405.2 = 1 is only possible if the encoder is connected at X520.  
Check the encoder/cable: Does the encoder supply TTL signals and the associated inverted signals?

Reaction upon N: NONE  
Acknowledge upon N: NONE  
Reaction upon A: NONE  
Acknowledge upon A: NONE

---

**F31118 (N, A) Encoder 1: Speed difference outside the tolerance range**

**Reaction:** A\_INFEED: NONE  
SERVO: ENCODER (DCBRAKE, NONE)  
VECTOR: ENCODER (DCBRAKE, NONE)

**Acknowledge:** PULSE INHIBIT

**Cause:** For an HTL/TTL encoder, the speed difference has exceeded the value in p0492 over several sampling cycles. Encoder 1 is used as motor encoder and can be effective has fault response to change over to sensorless operation.  
Fault value (r0949, decimal):  
Only for internal Siemens troubleshooting.  
See also: p0491 (Motor encoder fault response ENCODER)

**Remedy:** - check the tachometer feeder cable for interruptions.  
- check the grounding of the tachometer shielding.  
- if required, increase the maximum speed difference per sampling cycle (p0492).

Reaction upon N: NONE  
Acknowledge upon N: NONE  
Reaction upon A: NONE  
Acknowledge upon A: NONE

---

**F31120 (N, A) Encoder 1: Power supply voltage**

**Reaction:** A\_INFEED: NONE  
SERVO: ENCODER (DCBRAKE, NONE)  
VECTOR: ENCODER (DCBRAKE, NONE)

**Acknowledge:** PULSE INHIBIT

**Cause:** Encoder power supply voltage fault.  
Note:  
If the encoder cables 6FX2002-2EQ00-.... and 6FX2002-2CH00-.... are interchanged, this can result in the encoder being destroyed because the pins of the operating voltage are reversed.  
Fault value (r0949, interpret binary):  
Bit 0: Undervoltage condition on the sense line (threshold 4.75 V).  
Bit 1: Encoder power supply voltage overcurrent condition (threshold 450 mA).  
See also: p0491 (Motor encoder fault response ENCODER)

**Remedy:** For fault value, bit 0 = 1:  
- correct encoder cable connected?  
- check the plug connections of the encoder cable.  
- SMC30: Check the parameterization (p0404.22).  
For fault value, bit 1 = 1:  
- correct encoder cable connected?  
- replace the encoder or encoder cable.

Reaction upon N: NONE  
 Acknowledge upon N: NONE  
 Reaction upon A: NONE  
 Acknowledge upon A: NONE

**F31121 (N, A) Encoder 1: Coarse position error**

**Reaction:** A\_INFEED: NONE  
 SERVO: ENCODER (NONE)  
 VECTOR: ENCODER (NONE)

**Acknowledge:** PULSE INHIBIT

**Cause:** For the actual value sensing, an error was detected on the module. As a result of this error, it must be assumed that the actual value sensing supplies an incorrect coarse position.  
 See also: p0491 (Motor encoder fault response ENCODER)

**Remedy:** Replace the motor with DRIVE-CLiQ or the appropriate Sensor Module.

Reaction upon N: NONE  
 Acknowledge upon N: NONE  
 Reaction upon A: NONE  
 Acknowledge upon A: NONE

**F31125 (N, A) Encoder 1: Amplitude error track A or B overcontrolled**

**Reaction:** A\_INFEED: NONE  
 SERVO: ENCODER (DCBRAKE, NONE)  
 VECTOR: ENCODER (DCBRAKE, NONE)

**Acknowledge:** PULSE INHIBIT

**Cause:** The amplitude (track A or B) does not lie within the tolerance bandwidth (software monitoring function).  
 SMC20:  
 The nominal signal level of the encoder must lie in the range 375 mV to 600 mV (500 mV -25 % / +20 %).  
 On the other hand, the response threshold is > 760 mV (frequency characteristic).  
 SMC10:  
 The nominal signal level is at 2900 mV (2.0 Vrms). The response threshold is > 3582 mV.  
 Fault value (r0949, decimal):  
 Low word:  
 Signal level, track A (16 bits with sign).  
 High word:  
 Signal level, track B (16 bits with sign).  
 SMC20:  
 A signal level of 500 mV peak value corresponds to the numerical value 5333 hex = 21299 dec.  
 SMC10:  
 A signal level of 2900 mV peak value corresponds to the numerical value 6666 hex = 26214 dec.  
 See also: p0491 (Motor encoder fault response ENCODER)

**Remedy:**  
 - check that the encoder cables are routed in compliance with EMC.  
 - replace the encoder or encoder cable.  
 - with measuring systems without their own bearing system: Adjust the scanning head and check the bearing system of the measuring wheel.

Reaction upon N: NONE  
 Acknowledge upon N: NONE  
 Reaction upon A: NONE  
 Acknowledge upon A: NONE

<b>F31129 (N, A)</b>	<b>Encoder 1: Position difference, hall sensor/track C/D and A/B too large</b>
<b>Reaction:</b>	A_INFEED: NONE SERVO: ENCODER (DCBRAKE, NONE) VECTOR: ENCODER (DCBRAKE, NONE)
<b>Acknowledge:</b>	PULSE INHIBIT
<b>Cause:</b>	The error of track C/D is greater than +/-15 ° mechanical or +/-60 ° electrical. One period of track C/D corresponds to 360 ° mechanical. One period of the Hall signal corresponds to 360 ° electrical. The monitoring responds if, for example, Hall sensors are connected as equivalent for the C/D tracks with the incorrect rotational sense or supply values that are not accurate enough. After the fine synchronization using one reference mark or 2 reference marks for distance-coded encoders, this fault is no longer initiated, but instead, Alarm A31429. Fault value (r0949, decimal): Measured deviation as mechanical angle (16 bits with sign, 182 dec corresponds to 1 °). See also: p0491 (Motor encoder fault response ENCODER)
<b>Remedy:</b>	- track C or D not connected. - correct the direction of rotation of the Hall sensor possibly connected as equivalent for track C/D. - check that the encoder cables are routed in compliance with EMC. - check the adjustment of the Hall sensor.
Reaction upon N:	NONE
Acknowledge upon N:	NONE
Reaction upon A:	NONE
Acknowledge upon A:	NONE

<b>F31130 (N, A)</b>	<b>Encoder 1: Zero mark and position error from the coarse synchronization</b>
<b>Reaction:</b>	A_INFEED: NONE SERVO: ENCODER (DCBRAKE, NONE, OFF1, OFF2, OFF3, STOP1, STOP2) VECTOR: ENCODER (DCBRAKE, NONE, OFF1, OFF2, OFF3, STOP1, STOP2)
<b>Acknowledge:</b>	PULSE INHIBIT
<b>Cause:</b>	After initializing the pole position using track C/D, Hall signals or pole position identification routine, the zero mark was detected outside the permissible range. For distance-coded encoders, the test is carried-out after passing 2 zero marks. Fine synchronization was not carried-out. The deviation may be up to 18 ° mechanical or up to 60 ° electrical. Fault value (r0949, decimal): Normalization: 32768 = 180 ° High word: Mechanical zero mark position determined. If the initialization via a track C/D is selected in p0404, then it is checked whether the zero mark occurs in an angular range of +/-18 ° mechanical. Low word: Deviation of the zero mark from the expected position as electrical angle. If the correction of the commutation position with the zero mark is selected in p0404, then a difference of a maximum of +/- 60 ° electrical is permitted. See also: p0491 (Motor encoder fault response ENCODER)
<b>Remedy:</b>	- check p0431 and if required, correct - check that the encoder cables are routed in compliance with EMC. - check the plug connections. - if the Hall sensor is used as an equivalent for track C/D, check the connection. - check the connection of track C or D. - replace the encoder or encoder cable.
Reaction upon N:	NONE
Acknowledge upon N:	NONE
Reaction upon A:	NONE
Acknowledge upon A:	NONE

<b>F31131 (N, A)</b>	<b>Encoder 1: Deviation, position incremental/absolute too large</b>
<b>Reaction:</b>	A_INFEED: NONE SERVO: ENCODER (DCBRAKE, NONE, OFF1, OFF2, OFF3, STOP1, STOP2) VECTOR: ENCODER (DCBRAKE, NONE, OFF1, OFF2, OFF3, STOP1, STOP2)
<b>Acknowledge:</b>	PULSE INHIBIT
<b>Cause:</b>	Absolute encoder: When cyclically reading the absolute position, an excessively high difference to the incremental position was detected. The absolute position that was read is rejected. Limit value for the deviation: - EnDat encoder: Is supplied from the encoder and is a minimum of 2 quadrants (e.g. EQI 1325 > 2 quadrants, EQN 1325 > 50 quadrants). - other encoders: 15 pulses = 60 quadrants. Fault value (r0949, decimal): Deviation in quadrants (1 pulse = 4 quadrants). Incremental encoder: When the zero pulse is passed, a deviation in the incremental position was detected. See also: p0491 (Motor encoder fault response ENCODER)
<b>Remedy:</b>	- check that the encoder cables are routed in compliance with EMC. - check the plug connections. - replace the encoder or encoder cable. - check whether the coding disk is dirty or there are strong ambient magnetic fields.
Reaction upon N:	NONE
Acknowledge upon N:	NONE
Reaction upon A:	NONE
Acknowledge upon A:	NONE
<b>F31150 (N, A)</b>	<b>Encoder 1: Initialization error</b>
<b>Reaction:</b>	A_INFEED: NONE SERVO: ENCODER (DCBRAKE, NONE, OFF1, OFF2, OFF3, STOP1, STOP2) VECTOR: ENCODER (DCBRAKE, NONE, OFF1, OFF2, OFF3, STOP1, STOP2)
<b>Acknowledge:</b>	PULSE INHIBIT
<b>Cause:</b>	Encoder functionality selected in p0404 is not operating correctly. Fault value (r0949, interpret hexadecimal): The fault value is a bit field. Every set bit indicates functionality that is faulted. The bit assignment corresponds to that of p0404 (e.g. bit 5 set: Error track C/D). See also: p0404 (Encoder configuration effective), p0491 (Motor encoder fault response ENCODER)
<b>Remedy:</b>	- Check that p0404 is correctly set. - check the encoder type used (incremental/absolute value) and for SMCxx, the encoder cable. - if relevant, note additional fault/error messages that describe the fault in detail.
Reaction upon N:	NONE
Acknowledge upon N:	NONE
Reaction upon A:	NONE
Acknowledge upon A:	NONE
<b>A31400 (F, N)</b>	<b>Encoder 1: Alarm threshold, zero mark distance error</b>
<b>Reaction:</b>	NONE
<b>Acknowledge:</b>	NONE
<b>Cause:</b>	The measured zero mark distance does not correspond to the parameterized zero mark distance. For distance-coded encoders, the zero mark distance is determined from zero marks detected pairs. This means that if a zero mark is missing, depending on the pair generation, this cannot result in a fault and also has no effect in the system. The zero mark distance for the zero mark monitoring is set in p0425 (rotary encoder) or p0424 (linear encoder). Alarm value (r2124, decimal): Last measured zero mark distance in increments (4 increments = 1 encoder pulse). The sign designates the direction of motion when detecting the zero mark distance.

**Remedy:**

- check that the encoder cables are routed in compliance with EMC.
- check the plug connections.
- . check the encoder type (encoder with equidistant zero marks).
- adapt the parameter for the distance between zero marks (p0424, p0425).
- replace the encoder or encoder cable.

Reaction upon F: A\_INFEED: NONE (OFF1, OFF2)  
 SERVO: NONE (DCBRAKE, ENCODER, OFF1, OFF2, OFF3, STOP1, STOP2)  
 VECTOR: NONE (DCBRAKE, ENCODER, OFF1, OFF2, OFF3, STOP1, STOP2)

Acknowledge upon F: IMMEDIATELY

Reaction upon N: NONE

Acknowledge upon N: NONE

---

**A31401 (F, N) Encoder 1: Alarm threshold, zero marked failed**

**Reaction:** NONE

**Acknowledge:** NONE

**Cause:** The 1.5 x parameterized zero mark distance was exceeded.  
 The zero mark distance for the zero mark monitoring is set in p0425 (rotary encoder) or p0424 (linear encoder).  
 Alarm value (r2124, decimal):  
 Number of increments after POWER ON or since the last zero mark that was detected (4 increments = 1 encoder pulse).

**Remedy:**

- check that the encoder cables are routed in compliance with EMC.
- check the plug connections.
- . check the encoder type (encoder with equidistant zero marks).
- adapt the parameter for the clearance between zero marks (p0425).
- replace the encoder or encoder cable.

Reaction upon F: A\_INFEED: NONE (OFF1, OFF2)  
 SERVO: NONE (DCBRAKE, ENCODER, OFF1, OFF2, OFF3, STOP1, STOP2)  
 VECTOR: NONE (DCBRAKE, ENCODER, OFF1, OFF2, OFF3, STOP1, STOP2)

Acknowledge upon F: IMMEDIATELY

Reaction upon N: NONE

Acknowledge upon N: NONE

---

**F31405 (N, A) Encoder 1: Encoder evaluation temperature too high**

**Reaction:** A\_INFEED: NONE (OFF1, OFF2)  
 SERVO: NONE (DCBRAKE, OFF1, OFF2, OFF3, STOP1, STOP2)  
 VECTOR: NONE (DCBRAKE, OFF1, OFF2, OFF3, STOP1, STOP2)

**Acknowledge:** IMMEDIATELY (POWER ON)

**Cause:** The encoder evaluation for a motor with DRIVE-CLiQ has detected an excessively high temperature.  
 The fault threshold is 125 ° C.  
 Alarm value (r2124, decimal):  
 Measured board/module temperature in 0.1 °C.

**Remedy:** Reduce the ambient temperature for the DRIVE-CLiQ connection of the motor.

Reaction upon N: NONE

Acknowledge upon N: NONE

Reaction upon A: NONE

Acknowledge upon A: NONE

**A31410 (F, N) Encoder 1: Serial communications**

**Reaction:** NONE

**Acknowledge:** NONE

**Cause:** Serial communication protocol transfer error between the encoder and evaluation module.  
 Alarm value (r2124, interpret binary):  
 Bit 0: Alarm bit in the position protocol.  
 Bit 1: Incorrect quiescent level on the data line.  
 Bit 2: Encoder does not respond (does not supply a start bit within 50 ms).  
 Bit 3: CRC error: The checksum in the protocol from the encoder does not match the data.  
 Bit 4: Encoder acknowledgement error: The encoder incorrectly understood the task (request) or cannot execute it.  
 Bit 5: Internal error in the serial driver: An illegal mode command was requested.  
 Bit 6: Timeout with cyclically reading.  
 Bit 8: Protocol is too long (e.g. > 64 bits).  
 Bit 9: Receive buffer overflow.  
 Bit 10: Frame error when reading twice.  
 Bit 11: Parity error.  
 Bit 12: Data line signal level error during the monoflop time.

**Remedy:**

- check that the encoder cables are routed in compliance with EMC.
- check the plug connections.
- replace the encoder.

Reaction upon F: A\_INFEED: NONE (OFF1, OFF2)  
 SERVO: NONE (DCBRAKE, ENCODER, OFF1, OFF2, OFF3, STOP1, STOP2)  
 VECTOR: NONE (DCBRAKE, ENCODER, OFF1, OFF2, OFF3, STOP1, STOP2)

Acknowledge upon F: IMMEDIATELY

Reaction upon N: NONE

Acknowledge upon N: NONE

**A31411 (F, N) Encoder 1: EnDat encoder signals alarms**

**Reaction:** NONE

**Acknowledge:** NONE

**Cause:** The error word of the EnDat encoder has alarm bits that have been set.  
 Alarm value (r2124, interpret binary):  
 Bit 0: Frequency exceeded (speed too high).  
 Bit 1: Temperature exceeded.  
 Bit 2: Control reserve, lighting system exceeded.  
 Bit 3: Battery discharged.  
 Bit 4: Reference point passed.  
 See also: p0491 (Motor encoder fault response ENCODER)

**Remedy:** Replace encoder.

Reaction upon F: A\_INFEED: NONE (OFF1, OFF2)  
 SERVO: NONE (DCBRAKE, ENCODER, OFF1, OFF2, OFF3, STOP1, STOP2)  
 VECTOR: NONE (DCBRAKE, ENCODER, OFF1, OFF2, OFF3, STOP1, STOP2)

Acknowledge upon F: IMMEDIATELY

Reaction upon N: NONE

Acknowledge upon N: NONE

---

<b>A31414 (F, N)</b>	<b>Encoder 1: Amplitude error track C or D (C<sup>2</sup> + D<sup>2</sup>)</b>
<b>Reaction:</b>	NONE
<b>Acknowledge:</b>	NONE
<b>Cause:</b>	<p>The amplitude (C<sup>2</sup> + D<sup>2</sup>) of track C or D of the encoder or from the Hall signals, is not within the tolerance bandwidth.</p> <p>The nominal signal must be in the range 375 mV to 600 mV (500 mV -25 % / +20 %).</p> <p>On the other hand, the response thresholds are &lt; 230 mV and &gt; 750 mV (frequency characteristic).</p> <p>This fault also occurs if the A/D converter is overcontrolled.</p> <p>If the amplitude is not within the tolerance bandwidth, then it cannot be used to initialize the start position.</p> <p>Alarm value (r2124, decimal):</p> <p>Low word: Signal level, track C (16 bits with sign).</p> <p>High word: Signal level, track D (16 bits with sign).</p> <p>A signal level of 500 mV corresponds to the numerical value 5333 hex = 21299 dec.</p> <p>See also: p0491 (Motor encoder fault response ENCODER)</p>
<b>Remedy:</b>	<ul style="list-style-type: none"> <li>- check that the encoder cables are routed in compliance with EMC.</li> <li>- check the plug connections.</li> <li>- replace the encoder or encoder cable.</li> <li>- check the encoder module (e.g. contacts).</li> <li>- check the Hall sensor box</li> </ul>
Reaction upon F:	<p>A_INFEED: NONE (OFF1, OFF2)</p> <p>SERVO: NONE (DCBRAKE, ENCODER, OFF1, OFF2, OFF3, STOP1, STOP2)</p> <p>VECTOR: NONE (DCBRAKE, ENCODER, OFF1, OFF2, OFF3, STOP1, STOP2)</p>
Acknowledge upon F:	IMMEDIATELY
Reaction upon N:	NONE
Acknowledge upon N:	NONE

---

<b>N31415 (F, A)</b>	<b>Encoder 1: Amplitude alarm track A or B (A<sup>2</sup> + B<sup>2</sup>)</b>
<b>Reaction:</b>	NONE
<b>Acknowledge:</b>	NONE
<b>Cause:</b>	<p>The amplitude (A<sup>2</sup> + B<sup>2</sup>) of track A or B is not within the tolerance bandwidth.</p> <p>SMC20: The nominal signal level is at 500 mV (500 mV -25 % / +20 %). The response threshold is &lt; 300 mV.</p> <p>SMC10: The nominal signal level is at 2900 mV (2.0 Vrms). The response threshold is &lt; 1414 mV (1.0 Vrms).</p> <p>Alarm value (r2124, decimal):</p> <p>Low word: Amplitude square root(A*A + B*B).</p> <p>SMC20:</p> <p>A signal level of 500 mV peak value corresponds to the numerical value 299A hex = 10650 dec.</p> <p>SMC10:</p> <p>A signal level of 2900 mV peak value corresponds to the numerical value 3333 hex = 13107 dec.</p> <p>High word:</p> <p>Angle 0 to 65535 corresponds to 0 to 360 degrees of the fine position. Zero degrees is at the negative zero crossover of track B.</p> <p>See also: p0491 (Motor encoder fault response ENCODER)</p>
<b>Remedy:</b>	<ul style="list-style-type: none"> <li>- check the speed range, frequency characteristic (amplitude characteristic) of the measuring equipment is not sufficient for the speed range.</li> <li>- check that the encoder cables are routed in compliance with EMC.</li> <li>- check the plug connections.</li> <li>- replace the encoder or encoder cable.</li> <li>- check the encoder module (e.g. contacts).</li> <li>- dirty code disk</li> <li>- aged lighting system.</li> </ul>
Reaction upon F:	<p>A_INFEED: NONE (OFF1, OFF2)</p> <p>SERVO: NONE (DCBRAKE, ENCODER, OFF1, OFF2, OFF3, STOP1, STOP2)</p> <p>VECTOR: NONE (DCBRAKE, ENCODER, OFF1, OFF2, OFF3, STOP1, STOP2)</p>
Acknowledge upon F:	IMMEDIATELY
Reaction upon A:	NONE
Acknowledge upon A:	NONE



---

**A31418 (F, N) Encoder 1: Speed difference per sampling rate exceeded**

**Reaction:** NONE  
**Acknowledge:** NONE  
**Cause:** For an HTL/TTL encoder, the speed difference between two sampling cycles has exceeded the value in p0492.  
 Alarm value (r2124, decimal):  
 Only for internal Siemens troubleshooting.  
**Remedy:** - check the tachometer feeder cable for interruptions.  
 - check the grounding of the tachometer shielding.  
 - if required, increase the setting of p0492.  
 Reaction upon F: A\_INFEED: NONE (OFF1, OFF2)  
 SERVO: NONE (DCBRAKE, OFF1, OFF2, OFF3, STOP1, STOP2)  
 VECTOR: NONE (DCBRAKE, OFF1, OFF2, OFF3, STOP1, STOP2)  
 Acknowledge upon F: IMMEDIATELY  
 Reaction upon N: NONE  
 Acknowledge upon N: NONE

---

**A31419 (F, N) Encoder 1: Track A or B outside the tolerance range**

**Reaction:** NONE  
**Acknowledge:** NONE  
**Cause:** The amplitude, phase or offset correction for track A or B is at the limit.  
 Amplitude error correction: Amplitude B / Amplitude A = 0.78 ... 1.27  
 Phase: <84 degrees or >96 degrees  
 SMC20: Offset correction: +/-140 mV  
 SMC10: Offset correction: +/-650 mV  
 Alarm value (r2124, interpret hexadecimal):  
 xxx1: Minimum of the offset correction, track B  
 xxx2: Maximum of the offset correction, track B  
 xx1x: Minimum of the offset correction, track A  
 xx2x: Maximum of the offset correction, track A  
 x1xx: Minimum of the amplitude correction, track B/A  
 x2xx: Maximum of the amplitude correction, track B/A  
 1xxx: Minimum of the phase error correction  
 2xxx: Maximum of the phase error correction  
 See also: p0491 (Motor encoder fault response ENCODER)  
**Remedy:** - check mechanical mounting tolerances for encoders without their own bearings (e.g. toothed-wheel encoders).  
 - check the plug connections (also the transition resistance).  
 - check the encoder signals.  
 - replace the encoder or encoder cable.  
 Reaction upon F: A\_INFEED: NONE (OFF1, OFF2)  
 SERVO: NONE (DCBRAKE, ENCODER, OFF1, OFF2, OFF3, STOP1, STOP2)  
 VECTOR: NONE (DCBRAKE, ENCODER, OFF1, OFF2, OFF3, STOP1, STOP2)  
 Acknowledge upon F: IMMEDIATELY  
 Reaction upon N: NONE  
 Acknowledge upon N: NONE

**A31429 (F, N) Encoder 1: Position difference, hall sensor/track C/D and A/B too large**

**Reaction:** NONE

**Acknowledge:** NONE

**Cause:** The error of track C/D is greater than +/-15 ° mechanical or +/-60 ° electrical.  
 One period of track C/D corresponds to 360 ° mechanical.  
 One period of the Hall signal corresponds to 360 ° electrical.  
 The monitoring responds if, for example, Hall sensors are connected as equivalent for the C/D tracks with the incorrect rotational sense or supply values that are not accurate enough.  
 Alarm value (r2124, decimal):  
 Measured deviation as mechanical angle (16 bits with sign, 182 dec corresponds to 1 °).  
 See also: p0491 (Motor encoder fault response ENCODER)

**Remedy:**

- track C or D not connected.
- correct the direction of rotation of the Hall sensor possibly connected as equivalent for track C/D.
- check that the encoder cables are routed in compliance with EMC.
- check the adjustment of the Hall sensor.

Reaction upon F: A\_INFEED: NONE (OFF1, OFF2)  
 SERVO: NONE (DCBRAKE, ENCODER, OFF1, OFF2, OFF3, STOP1, STOP2)  
 VECTOR: NONE (DCBRAKE, ENCODER, OFF1, OFF2, OFF3, STOP1, STOP2)

Acknowledge upon F: IMMEDIATELY

Reaction upon N: NONE

Acknowledge upon N: NONE

**A31431 (F, N) Encoder 1: Deviation, position incremental/absolute too large**

**Reaction:** NONE

**Acknowledge:** NONE

**Cause:** Absolute encoder: When cyclically reading the absolute position, an excessively high difference to the incremental position was detected.  
 Alarm value (r2124, decimal):  
 Deviation in quadrants (1 pulse = 4 quadrants).  
 Incremental encoder: When the zero pulse is passed, a deviation in the incremental position was detected.  
 See also: p0491 (Motor encoder fault response ENCODER)

**Remedy:**

- check that the encoder cables are routed in compliance with EMC.
- check the plug connections.
- replace the encoder or encoder cable.
- coding disk dirty or strong magnetic fields.

Reaction upon F: A\_INFEED: NONE (OFF1, OFF2)  
 SERVO: NONE (DCBRAKE, ENCODER, OFF1, OFF2, OFF3, STOP1, STOP2)  
 VECTOR: NONE (DCBRAKE, ENCODER, OFF1, OFF2, OFF3, STOP1, STOP2)

Acknowledge upon F: IMMEDIATELY

Reaction upon N: NONE

Acknowledge upon N: NONE

**F31501 (N, A) Encoder 1: Position tracking encoder position outside tolerance window**

**Reaction:** A\_INFEED: NONE  
 SERVO: OFF1 (NONE, OFF2, OFF3)  
 VECTOR: OFF1 (NONE, OFF2, OFF3)

**Acknowledge:** IMMEDIATELY

**Cause:** When powered-down, the drive/encoder was moved through a distance greater than what was set in the tolerance window.  
 See also: p0413 (Measuring gearbox, position tracking tolerance window)

**Remedy:** Re-adjust the drive.

Reaction upon N: NONE

Acknowledge upon N: NONE

Reaction upon A: NONE  
 Acknowledge upon A: NONE

---

**F31502 (N, A) Encoder 1: Encoder with measuring gear, without valid signals**

**Reaction:** A\_INFEED: OFF1 (OFF2)  
 SERVO: OFF1 (OFF2, OFF3)  
 VECTOR: OFF1 (OFF2, OFF3)

**Acknowledge:** IMMEDIATELY

**Cause:** The encoder with measuring gear no longer provides any valid signals.

**Remedy:** It must be ensured that all of the encoders, with mounted measuring gear, provide valid actual values in operation.

Reaction upon N: NONE  
 Acknowledge upon N: NONE

Reaction upon A: NONE  
 Acknowledge upon A: NONE

---

**F31801 (N, A) Encoder 1 DRIVE-CLiQ: Sign-of-life missing**

**Reaction:** A\_INFEED: OFF2 (NONE)  
 SERVO: ENCODER (DCBRAKE, NONE)  
 VECTOR: ENCODER (DCBRAKE, NONE)

**Acknowledge:** IMMEDIATELY

**Cause:** DRIVE-CLiQ communications error between the Control Unit and the encoder involved.  
 Fault value (r0949, interpret hexadecimal):  
 0A: The sign-of-life bit in the receive telegram is not set.  
 See also: p0491 (Motor encoder fault response ENCODER)

**Remedy:** - check the electrical cabinet design and cable routing for EMC compliance.  
 - replace the component involved.  
 See also: p9916 (DRIVE-CLiQ data transfer error, shutdown threshold, slave)

Reaction upon N: NONE  
 Acknowledge upon N: NONE

Reaction upon A: NONE  
 Acknowledge upon A: NONE

---

**F31802 (N, A) Encoder 1: Time slice overflow**

**Reaction:** A\_INFEED: OFF2 (NONE)  
 SERVO: ENCODER (DCBRAKE, NONE)  
 VECTOR: ENCODER (DCBRAKE, NONE)

**Acknowledge:** IMMEDIATELY

**Cause:** Time slice overflow, encoder 1.  
 Fault value (r0949, decimal):  
 9: Time slice overflow of the fast (current controller clock cycle) time slice.  
 10: Time slice overflow of the average time slice.  
 12: Time slice overflow of the slow time slice.  
 999: Timeout when waiting for SYNO, e.g. unexpected return to non-cyclic operation.  
 See also: p0491 (Motor encoder fault response ENCODER)

**Remedy:** Reduce the current controller frequency.

Reaction upon N: NONE  
 Acknowledge upon N: NONE

Reaction upon A: NONE  
 Acknowledge upon A: NONE

---

**F31804 (N, A) Encoder 1: CRC CODE RAM**

**Reaction:** A\_INFEED: OFF2 (NONE)  
 SERVO: ENCODER (DCBRAKE, NONE)  
 VECTOR: ENCODER (DCBRAKE, NONE)

**Acknowledge:** IMMEDIATELY

**Cause:** The checksum via the CODE-RAM of the Sensor Module has changed in operation.  
 Fault value (r0949, interpret hexadecimal):  
 Difference between the checksum at POWER ON and the actual checksum.  
 See also: p0491 (Motor encoder fault response ENCODER)

**Remedy:** Hardware defect: Replace the Sensor Module.  
 Firmware error: If required, upgrade the firmware.

Reaction upon N: NONE  
 Acknowledge upon N: NONE  
 Reaction upon A: NONE  
 Acknowledge upon A: NONE

---

**F31805 (N, A) Encoder 1: EPROM checksum error**

**Reaction:** A\_INFEED: OFF2 (NONE)  
 SERVO: ENCODER (DCBRAKE, NONE)  
 VECTOR: ENCODER (DCBRAKE, NONE)

**Acknowledge:** IMMEDIATELY

**Cause:** Internal parameter data is corrupted.  
 Fault value (r0949, interpret hexadecimal):  
 01: EEPROM access error.  
 02: Too many blocks in the EEPROM.  
 See also: p0491 (Motor encoder fault response ENCODER)

**Remedy:** Replace the module.

Reaction upon N: NONE  
 Acknowledge upon N: NONE  
 Reaction upon A: NONE  
 Acknowledge upon A: NONE

---

**F31806 (N, A) Encoder 1: Initialization error**

**Reaction:** A\_INFEED: OFF2 (NONE)  
 SERVO: ENCODER (DCBRAKE, NONE)  
 VECTOR: ENCODER (DCBRAKE, NONE)

**Acknowledge:** PULSE INHIBIT

**Cause:** The encoder was not successfully initialized.  
 Fault value (r0949, interpret hexadecimal):  
 1, 2, 3: Encoder initialization with the motor rotating.  
 See also: p0491 (Motor encoder fault response ENCODER)

**Remedy:** Acknowledge the fault.

Reaction upon N: NONE  
 Acknowledge upon N: NONE  
 Reaction upon A: NONE  
 Acknowledge upon A: NONE

---

<b>F31811 (N, A)</b>	<b>Encoder 1: Encoder serial number changed</b>
<b>Reaction:</b>	A_INFEED: OFF2 (NONE) SERVO: NONE (ENCODER, OFF2) VECTOR: NONE (ENCODER, OFF2)
<b>Acknowledge:</b>	IMMEDIATELY
<b>Cause:</b>	The serial number of the motor encoder of a synchronous motor has changed. The change was only checked for encoders with serial number (e.g. EnDat encoders) and build-in motors (e.g. p300 = 401) or third-party motors (p0300 = 2). Cause 1: The motor with integrated and adjusted encoder was replaced. Cause 2: The encoder was replaced. Cause 3: A third-party, build-in or linear motor was re-commissioned. Cause 4: The firmware was updated to a version that checks the encoder serial number. If the position control is active, the serial numbers of the adjusted encoders (p2507 = 3) are checked. If the serial number has changed, the adjustment is reset (p2507 = 1). See also: p0491 (Motor encoder fault response ENCODER)
<b>Remedy:</b>	Re causes 1, 4: Accept the new serial number with p0440 = 1. Re causes 2, 3: Carry-out an automatic adjustment using the pole position identification routine. First, accept the serial number with p0440 = 1. Acknowledge the fault. Initiate the pole position identification routine with p1990 = 1. Then check that the pole position identification routine is correctly executed. SERVO: If a pole position identification technique is selected in p1980, and if p0301 does not contain a motor type with an encoder adjusted in the factory, then p1990 is automatically activated. or Set the adjustment using parameter p0431. In this case, the new serial number is automatically accepted. or Mechanically adjust the encoder. Accept the new serial number with p0440 = 1.
Reaction upon N:	NONE
Acknowledge upon N:	NONE
Reaction upon A:	NONE
Acknowledge upon A:	NONE

---

<b>F31812 (N, A)</b>	<b>Encoder 1: A cycle requested from the CU or RX/TX timing is not supported</b>
<b>Reaction:</b>	OFF2
<b>Acknowledge:</b>	IMMEDIATELY
<b>Cause:</b>	A cycle requested from the CU or RX/TX timing is not supported Fault value (r0949): 0: Application cycle is not supported. 1: DQ cycle is not supported. 2: Clearance between RX and TX instants in time too low. 3: TX instant in time too early.
<b>Remedy:</b>	
Reaction upon N:	NONE
Acknowledge upon N:	NONE
Reaction upon A:	NONE
Acknowledge upon A:	NONE

---

**F31820 (N, A) Encoder 1 DRIVE-CLiQ: Telegram error**

**Reaction:** A\_INFEED: OFF2  
SERVO: ENCODER (DCBRAKE, NONE)  
VECTOR: ENCODER (DCBRAKE, NONE)

**Acknowledge:** IMMEDIATELY

**Cause:** DRIVE-CLiQ communications error between the Control Unit and the encoder involved.  
Fault value (r0949, interpret hexadecimal):  
01: CRC error.  
02: Telegram is shorter than specified in the length byte or in the receive list.  
03: Telegram is longer than specified in the length byte or in the receive list.  
04: The length of the receive telegram does not match the receive list.  
05: The type of the receive telegram does not match the receive list.  
06: The address of the encoder in the telegram and in the receive list do not match.  
07: The encoder expects a SYNC telegram, but the receive telegram is not a SYNC telegram.  
08: The encoder does not expect a SYNC telegram, but the receive telegram is a SYNC telegram.  
09: The error bit in the receive telegram is set.  
10: The receive telegram is too early.  
See also: p0491 (Motor encoder fault response ENCODER)

**Remedy:** - carry-out a POWER ON.  
- check the electrical cabinet design and cable routing for EMC compliance.  
- check the DRIVE-CLiQ wiring (interrupted cable, contacts, ...).  
See also: p9916 (DRIVE-CLiQ data transfer error, shutdown threshold, slave)

Reaction upon N: NONE  
Acknowledge upon N: NONE  
Reaction upon A: NONE  
Acknowledge upon A: NONE

---

**F31835 (N, A) Encoder 1 DRIVE-CLiQ: Cyclic data transfer error**

**Reaction:** A\_INFEED: OFF2  
SERVO: ENCODER (DCBRAKE, NONE)  
VECTOR: ENCODER (DCBRAKE, NONE)

**Acknowledge:** IMMEDIATELY

**Cause:** DRIVE-CLiQ communications error between the Control Unit and the encoder involved. The nodes do not send and receive in synchronism.  
Fault value (r0949, interpret hexadecimal):  
21: The cyclic telegram has not been received.  
22: Timeout in the telegram receive list.  
40: Timeout in the telegram send list.  
See also: p0491 (Motor encoder fault response ENCODER)

**Remedy:** - carry-out a POWER ON.  
- replace the component involved.  
See also: p9916 (DRIVE-CLiQ data transfer error, shutdown threshold, slave)

Reaction upon N: NONE  
Acknowledge upon N: NONE  
Reaction upon A: NONE  
Acknowledge upon A: NONE

---

**F31836 (N, A) Encoder 1 DRIVE-CLiQ: Send error for DRIVE-CLiQ data**

**Reaction:** A\_INFEED: OFF2  
SERVO: ENCODER (DCBRAKE, NONE)  
VECTOR: ENCODER (DCBRAKE, NONE)

**Acknowledge:** IMMEDIATELY

**Cause:** DRIVE-CLiQ communications error between the Control Unit and the encoder involved. Data were not able to be sent.  
Fault value (r0949, interpret hexadecimal):  
41: Telegram type does not match send list.  
See also: p0491 (Motor encoder fault response ENCODER)

**Remedy:** Carry-out a POWER ON.

Reaction upon N: NONE  
Acknowledge upon N: NONE  
Reaction upon A: NONE  
Acknowledge upon A: NONE

---

**F31837 (N, A) Encoder 1 DRIVE-CLiQ: Component fault**

**Reaction:** A\_INFEED: OFF2  
SERVO: ENCODER (DCBRAKE, NONE)  
VECTOR: ENCODER (DCBRAKE, NONE)

**Acknowledge:** IMMEDIATELY

**Cause:** Fault detected on the DRIVE-CLiQ component involved. Faulty hardware cannot be excluded.  
Fault value (r0949, interpret hexadecimal):  
20: Error in the telegram header.  
23: Receive error: The telegram buffer memory contains an error.  
42: Send error: The telegram buffer memory contains an error.  
43: Send error: The telegram buffer memory contains an error.  
See also: p0491 (Motor encoder fault response ENCODER)

**Remedy:** - check the DRIVE-CLiQ wiring (interrupted cable, contacts, ...).  
- check the electrical cabinet design and cable routing for EMC compliance.  
- if required, use another DRIVE-CLiQ socket (p9904).  
- replace the component involved.

Reaction upon N: NONE  
Acknowledge upon N: NONE  
Reaction upon A: NONE  
Acknowledge upon A: NONE

---

**F31845 (N, A) Encoder 1 DRIVE-CLiQ: Cyclic data transfer error**

**Reaction:** A\_INFEED: OFF2  
SERVO: ENCODER (DCBRAKE, NONE)  
VECTOR: ENCODER (DCBRAKE, NONE)

**Acknowledge:** IMMEDIATELY

**Cause:** DRIVE-CLiQ communications error between the Control Unit and the encoder involved.  
Fault value (r0949, interpret hexadecimal):  
0B: Synchronization error during alternating cyclic data transfer.  
See also: p0491 (Motor encoder fault response ENCODER)

**Remedy:** Carry-out a POWER ON.  
See also: p9916 (DRIVE-CLiQ data transfer error, shutdown threshold, slave)

Reaction upon N: NONE  
Acknowledge upon N: NONE  
Reaction upon A: NONE  
Acknowledge upon A: NONE

---

**F31850 (N, A) Encoder 1: Sensor Module, internal software error**

**Reaction:** A\_INFEED: OFF2 (NONE)  
 SERVO: ENCODER (DCBRAKE, NONE)  
 VECTOR: ENCODER (DCBRAKE, NONE)

**Acknowledge:** POWER ON

**Cause:** Internal software error in the Sensor Module of encoder 1.  
 Fault value (r0949, decimal):  
 1: Background time slice is blocked.  
 2: Checksum over the code memory is not OK.  
 10000: OEM memory of the EnDat encoder contains data that cannot be interpreted.  
 See also: p0491 (Motor encoder fault response ENCODER)

**Remedy:**  
 - replace the Sensor Module.  
 - if required, upgrade the firmware in the Sensor Module.  
 - contact the Hotline.

Reaction upon N: NONE  
 Acknowledge upon N: NONE  
 Reaction upon A: NONE  
 Acknowledge upon A: NONE

---

**F31851 (N, A) CU DRIVE-CLiQ: Sign-of-life missing**

**Reaction:** A\_INFEED: NONE (OFF1, OFF2)  
 SERVO: ENCODER (DCBRAKE, NONE)  
 VECTOR: ENCODER (DCBRAKE, NONE)

**Acknowledge:** IMMEDIATELY

**Cause:** A DRIVE-CLiQ communications error has occurred between the Control Unit and the Sensor Module (encoder 1) involved. The DRIVE-CLiQ component did not set the sign of life to the Control Unit.  
 Fault value (r0949, interpret hexadecimal):  
 0A: The sign-of-life bit in the receive telegram is not set.

**Remedy:** Upgrade the firmware of the component involved.

Reaction upon N: NONE  
 Acknowledge upon N: NONE  
 Reaction upon A: NONE  
 Acknowledge upon A: NONE



---

**F31860 (N, A) CU DRIVE-CLiQ: Telegram error**

**Reaction:** A\_INFEED: NONE (OFF1, OFF2)  
 SERVO: ENCODER (DCBRAKE, NONE)  
 VECTOR: ENCODER (DCBRAKE, NONE)

**Acknowledge:** IMMEDIATELY

**Cause:** DRIVE-CLiQ communications error between the Control Unit and the encoder involved.  
 Fault value (r0949, interpret hexadecimal):  
 11: CRC error and the receive telegram is too early.  
 01: CRC error.  
 12: The telegram is shorter than that specified in the length byte or in the receive list and the receive telegram is too early.  
 02: Telegram is shorter than specified in the length byte or in the receive list.  
 13: The telegram is longer than that specified in the length byte or in the receive list and the receive telegram is too early.  
 03: Telegram is longer than specified in the length byte or in the receive list.  
 14: The length of the receive telegram does not match the receive list and the receive telegram is too early.  
 04: The length of the receive telegram does not match the receive list.  
 15: The type of the receive telegram does not match the receive list and the receive telegram is too early.  
 05: The type of the receive telegram does not match the receive list.  
 16: The address of the encoder in the telegram and in the receive list does not match and the receive telegram is too early.  
 06: The address of the encoder in the telegram and in the receive list do not match.  
 19: The error bit in the receive telegram is set and the receive telegram is too early.  
 09: The error bit in the receive telegram is set.  
 10: The receive telegram is too early.

**Remedy:** - carry-out a POWER ON.  
 - check the electrical cabinet design and cable routing for EMC compliance.  
 - check the DRIVE-CLiQ wiring (interrupted cable, contacts, ...).  
 See also: p9915 (DRIVE-CLiQ data transfer error, shutdown threshold, master)

Reaction upon N: NONE  
 Acknowledge upon N: NONE  
 Reaction upon A: NONE  
 Acknowledge upon A: NONE

---

**F31885 (N, A) CU DRIVE-CLiQ: Cyclic data transfer error**

**Reaction:** A\_INFEED: NONE (OFF1, OFF2)  
 SERVO: ENCODER (DCBRAKE, NONE)  
 VECTOR: ENCODER (DCBRAKE, NONE)

**Acknowledge:** IMMEDIATELY

**Cause:** DRIVE-CLiQ communications error between the Control Unit and the encoder involved. The nodes do not send and receive in synchronism.  
 Fault value (r0949, interpret hexadecimal):  
 1A: Sign-of-life bit in the receive telegram not set and the receive telegram is too early.  
 21: The cyclic telegram has not been received.  
 22: Timeout in the telegram receive list.  
 40: Timeout in the telegram send list.  
 62: Error at the transition to cyclic operation.

**Remedy:** - check the power supply voltage of the component involved.  
 - carry-out a POWER ON.  
 - replace the component involved.  
 See also: p9915 (DRIVE-CLiQ data transfer error, shutdown threshold, master)

Reaction upon N: NONE  
 Acknowledge upon N: NONE  
 Reaction upon A: NONE  
 Acknowledge upon A: NONE

---

**F31886 (N, A) CU DRIVE-CLiQ: Error when sending DRIVE-CLiQ data**

**Reaction:** A\_INFEED: NONE (OFF1, OFF2)  
SERVO: ENCODER (DCBRAKE, NONE)  
VECTOR: ENCODER (DCBRAKE, NONE)

**Acknowledge:** IMMEDIATELY

**Cause:** DRIVE-CLiQ communications error between the Control Unit and the encoder involved. Data were not able to be sent.  
Fault value (r0949, interpret hexadecimal):  
41: Telegram type does not match send list.

**Remedy:** - carry-out a POWER ON.  
- check whether the firmware version of the encoder (r0148) matches the firmware version of Control Unit (r0018).

Reaction upon N: NONE  
Acknowledge upon N: NONE  
Reaction upon A: NONE  
Acknowledge upon A: NONE

---

**F31887 (N, A) CU DRIVE-CLiQ: Component fault**

**Reaction:** A\_INFEED: NONE (OFF1, OFF2)  
SERVO: ENCODER (DCBRAKE, NONE)  
VECTOR: ENCODER (DCBRAKE, NONE)

**Acknowledge:** IMMEDIATELY

**Cause:** Fault detected on the DRIVE-CLiQ component involved. Faulty hardware cannot be excluded.  
Fault value (r0949, interpret hexadecimal):  
20: Error in the telegram header.  
23: Receive error: The telegram buffer memory contains an error.  
42: Send error: The telegram buffer memory contains an error.  
43: Send error: The telegram buffer memory contains an error.  
60: Response received too late during runtime measurement.  
61: Time taken to exchange characteristic data too long.

**Remedy:** - check the DRIVE-CLiQ wiring (interrupted cable, contacts, ...).  
- check the electrical cabinet design and cable routing for EMC compliance.  
- if required, use another DRIVE-CLiQ socket (p9904).  
- replace the component involved.

Reaction upon N: NONE  
Acknowledge upon N: NONE  
Reaction upon A: NONE  
Acknowledge upon A: NONE

---

**F31895 (N, A) CU DRIVE-CLiQ: Cyclic data transfer error**

**Reaction:** A\_INFEED: NONE (OFF1, OFF2)  
SERVO: ENCODER (DCBRAKE, NONE)  
VECTOR: ENCODER (DCBRAKE, NONE)

**Acknowledge:** IMMEDIATELY

**Cause:** DRIVE-CLiQ communications error between the Control Unit and the encoder involved.  
Fault value (r0949, interpret hexadecimal):  
0B: Synchronization error during alternating cyclic data transfer.

**Remedy:** Carry-out a POWER ON.  
See also: p9915 (DRIVE-CLiQ data transfer error, shutdown threshold, master)

Reaction upon N: NONE  
Acknowledge upon N: NONE  
Reaction upon A: NONE  
Acknowledge upon A: NONE

---

<b>F31896 (N, A)</b>	<b>CU DRIVE-CLiQ: Inconsistent component characteristics</b>
<b>Reaction:</b>	A_INFEED: NONE (OFF1, OFF2) SERVO: OFF2 (DCBRAKE, ENCODER, NONE, OFF1, OFF3, STOP1, STOP2) VECTOR: OFF2 (DCBRAKE, ENCODER, NONE, OFF1, OFF3, STOP1, STOP2)
<b>Acknowledge:</b>	IMMEDIATELY
<b>Cause:</b>	The properties of the DRIVE-CLiQ component, specified by the fault value, have changed in an incompatible fashion with respect to the properties when booted. One cause can be, e.g. that a DRIVE-CLiQ cable or DRIVE-CLiQ component has been replaced. Fault value (r0949, decimal): Component ID.
<b>Remedy:</b>	- when replacing cables, only use cables with the same length as the original cables. - when replacing components, use the same components and firmware releases. - carry-out a POWER ON.
Reaction upon N:	NONE
Acknowledge upon N:	NONE
Reaction upon A:	NONE
Acknowledge upon A:	NONE

---

<b>F31897 (N, A)</b>	<b>DRIVE-CLiQ: No communication to component</b>
<b>Reaction:</b>	A_INFEED: NONE (OFF1, OFF2) SERVO: ENCODER (DCBRAKE, NONE, OFF1, OFF2, OFF3, STOP1, STOP2) VECTOR: ENCODER (DCBRAKE, NONE, OFF1, OFF2, OFF3, STOP1, STOP2)
<b>Acknowledge:</b>	IMMEDIATELY (POWER ON)
<b>Cause:</b>	Communications with the DRIVE-CLiQ component specified by the fault value is not possible. One cause can be, e.g. that a DRIVE-CLiQ cable has been withdrawn. Fault value (r0949, decimal): Component ID.
<b>Remedy:</b>	- check the DRIVE-CLiQ connections. - carry-out a POWER ON.
Reaction upon N:	NONE
Acknowledge upon N:	NONE
Reaction upon A:	NONE
Acknowledge upon A:	NONE

---

<b>F31899 (N, A)</b>	<b>Encoder 1: Unknown fault</b>
<b>Reaction:</b>	A_INFEED: OFF2 (NONE, OFF1) SERVO: ENCODER (DCBRAKE, NONE, OFF1, OFF2, OFF3, STOP1, STOP2) VECTOR: ENCODER (DCBRAKE, NONE, OFF1, OFF2, OFF3, STOP1, STOP2)
<b>Acknowledge:</b>	IMMEDIATELY (POWER ON)
<b>Cause:</b>	A fault occurred on the Sensor Module for encoder 1 that cannot be interpreted by the Control Unit firmware. This can occur if the firmware on the Sensor Module for encoder 1 is more recent than the firmware on the Control Unit. Fault value (r0949, decimal): Fault number. If required, the significance of this new fault can be read about in a more recent description of the Control Unit. See also: p0491 (Motor encoder fault response ENCODER)
<b>Remedy:</b>	- replace the firmware on the Sensor Module by an older firmware version (r0148). - upgrade the firmware on the Control Unit (r0018).
Reaction upon N:	NONE
Acknowledge upon N:	NONE
Reaction upon A:	NONE
Acknowledge upon A:	NONE

---

<b>F31905 (N, A)</b>	<b>Encoder 1: Parameterization error</b>
<b>Reaction:</b>	A_INFEED: OFF2 (NONE, OFF1) SERVO: ENCODER (DCBRAKE, NONE, OFF1, OFF2, OFF3, STOP1, STOP2) VECTOR: ENCODER (DCBRAKE, NONE, OFF1, OFF2, OFF3, STOP1, STOP2)
<b>Acknowledge:</b>	IMMEDIATELY
<b>Cause:</b>	A parameter of encoder 1 was detected as being incorrect. It is possible that the parameterized encoder type does not match the connected encoder. The parameter involved can be determined as follows: - determine the parameter number using the fault value (r0949). - determine the parameter index (p0187). Fault value (r0949, decimal): Parameter number. See also: p0491 (Motor encoder fault response ENCODER)
<b>Remedy:</b>	- check whether the connected encoder type matches the encoder that has been parameterized. - correct the parameter specified by the fault value (r0949) and p0187.
Reaction upon N:	NONE
Acknowledge upon N:	NONE
Reaction upon A:	NONE
Acknowledge upon A:	NONE

---

<b>A31920 (F, N)</b>	<b>Encoder 1: Temperature sensor fault</b>
<b>Reaction:</b>	NONE
<b>Acknowledge:</b>	NONE
<b>Cause:</b>	When evaluating the temperature sensor, an error occurred. Alarm value (r2124, decimal): 1: Wire breakage or sensor not connected (KTY: R > 1630 Ohm). 2: Measured resistance too low (PTC: R < 20 Ohm, KTY: R < 50 Ohm). See also: p0491 (Motor encoder fault response ENCODER)
<b>Remedy:</b>	- check that the encoder cable is the correct type and is correctly connected. - check the temperature sensor selection in p0600 to p0603. - replace the Sensor Module (hardware defect or incorrect calibration data).
Reaction upon F:	A_INFEED: NONE (OFF1, OFF2) SERVO: NONE (DCBRAKE, ENCODER, OFF1, OFF2, OFF3, STOP1, STOP2) VECTOR: NONE (DCBRAKE, ENCODER, OFF1, OFF2, OFF3, STOP1, STOP2)
Acknowledge upon F:	IMMEDIATELY
Reaction upon N:	NONE
Acknowledge upon N:	NONE

---

<b>A31999 (F, N)</b>	<b>Encoder 1: Unknown alarm</b>
<b>Reaction:</b>	NONE
<b>Acknowledge:</b>	NONE
<b>Cause:</b>	A alarm has occurred on the Sensor Module for encoder 1 that cannot be interpreted by the Control Unit firmware. This can occur if the firmware on the Sensor Module for encoder 1 is more recent than the firmware on the Control Unit. Alarm value (r2124, decimal): Alarm number. If required, the significance of this new alarm can be read about in a more recent description of the Control Unit. See also: p0491 (Motor encoder fault response ENCODER)
<b>Remedy:</b>	- replace the firmware on the Sensor Module by an older firmware version (r0148). - upgrade the firmware on the Control Unit (r0018).

Reaction upon F: A\_INFEED: NONE (OFF1, OFF2)  
 SERVO: NONE (DCBRAKE, ENCODER, OFF1, OFF2, OFF3, STOP1, STOP2)  
 VECTOR: NONE (DCBRAKE, ENCODER, OFF1, OFF2, OFF3, STOP1, STOP2)

Acknowledge upon F: IMMEDIATELY (POWER ON)

Reaction upon N: NONE

Acknowledge upon N: NONE

**F32100 (N, A) Encoder 2: Zero mark clearance error**

**Reaction:** A\_INFEED: NONE (OFF1, OFF2)  
 SERVO: OFF1 (DCBRAKE, NONE, OFF2, OFF3, STOP1, STOP2)  
 VECTOR: OFF1 (DCBRAKE, NONE, OFF2, OFF3, STOP1, STOP2)

**Acknowledge:** PULSE INHIBIT

**Cause:** The measured zero mark distance does not correspond to the parameterized zero mark distance. For distance-coded encoders, the zero mark distance is determined from zero marks detected pairs. This means that if a zero mark is missing, depending on the pair generation, this cannot result in a fault and also has no effect in the system.  
 The zero mark distance for the zero mark monitoring is set in p0425 (rotary encoder) or p0424 (linear encoder).  
 Fault value (r0949, decimal):  
 Last measured zero mark distance in increments (4 increments = 1 encoder pulse).  
 The sign designates the direction of motion when detecting the zero mark distance.

**Remedy:**

- check that the encoder cables are routed in compliance with EMC.
- check the plug connections.
- . check the encoder type (encoder with equidistant zero marks).
- adapt the parameter for the distance between zero marks (p0424, p0425).
- replace the encoder or encoder cable.

Reaction upon N: NONE

Acknowledge upon N: NONE

Reaction upon A: NONE

Acknowledge upon A: NONE

**F32101 (N, A) Encoder 2: Zero marked failed**

**Reaction:** A\_INFEED: NONE (OFF1, OFF2)  
 SERVO: OFF1 (DCBRAKE, NONE, OFF2, OFF3, STOP1, STOP2)  
 VECTOR: OFF1 (DCBRAKE, NONE, OFF2, OFF3, STOP1, STOP2)

**Acknowledge:** PULSE INHIBIT

**Cause:** The 1.5 x parameterized zero mark distance was exceeded.  
 The zero mark distance for the zero mark monitoring is set in p0425 (rotary encoder) or p0424 (linear encoder).  
 Fault value (r0949, decimal):  
 Number of increments after POWER ON or since the last zero mark that was detected (4 increments = 1 encoder pulse).

**Remedy:**

- check that the encoder cables are routed in compliance with EMC.
- check the plug connections.
- . check the encoder type (encoder with equidistant zero marks).
- adapt the parameter for the clearance between zero marks (p0425).
- replace the encoder or encoder cable.

Reaction upon N: NONE

Acknowledge upon N: NONE

Reaction upon A: NONE

Acknowledge upon A: NONE

**F32110 (N, A) Encoder 2: Serial communications error**

**Reaction:** A\_INFEED: NONE  
 SERVO: OFF1 (DCBRAKE, NONE, OFF2, OFF3)  
 VECTOR: OFF1 (DCBRAKE, NONE, OFF2, OFF3)

**Acknowledge:** PULSE INHIBIT

**Cause:** Serial communication protocol transfer error between the encoder and evaluation module.  
 Fault value (r0949, interpret binary):  
 Bit 0: Alarm bit in the position protocol.  
 Bit 1: Incorrect quiescent level on the data line.  
 Bit 2: Encoder does not respond (does not supply a start bit within 50 ms).  
 Bit 3: CRC error: The checksum in the protocol from the encoder does not match the data.  
 Bit 4: Encoder acknowledgement error: The encoder incorrectly understood the task (request) or cannot execute it.  
 Bit 5: Internal error in the serial driver: An illegal mode command was requested.  
 Bit 6: Timeout with cyclically reading.  
 Bit 8: Protocol is too long (e.g. > 64 bits).  
 Bit 9: Receive buffer overflow  
 Bit 10: Frame error when reading twice.  
 Bit 11: Parity error.  
 Bit 12: Data line signal level error during the monoflop time.

**Remedy:** Re fault value:  
 Bit 0 = 1: Encoder defective. F31111 may provide additional details.  
 Bit 1 = 1: Incorrect encoder type / replace the encoder or encoder cable.  
 Bit 2 = 1: Incorrect encoder type / replace the encoder or encoder cable.  
 Bit 3 = 1: EMC / connect the cable shield, replace the encoder or encoder cable.  
 Bit 4 = 1: EMC / connect the cable shield, replace the encoder or encoder cable, replace the Sensor Module.  
 Bit 5 = 1: EMC / connect the cable shield, replace the encoder or encoder cable, replace the Sensor Module.  
 Bit 6 = 1: Update the Sensor Module firmware.  
 Bit 8 = 1: Check the parameterization (p0429.2).  
 Bit 9 = 1: EMC / connect the cable shield, replace the encoder or encoder cable, replace the Sensor Module.  
 Bit 10 = 1: Check the parameterization (p0429.2, p0449).  
 Bit 11 = 1: Check the parameterization (p0436).  
 Bit 12 = 1: Check the parameterization (p0429.6).

Reaction upon N: NONE  
 Acknowledge upon N: NONE  
 Reaction upon A: NONE  
 Acknowledge upon A: NONE

**F32111 (N, A) Encoder 2: Absolute encoder EnDat, internal fault/error**

**Reaction:** A\_INFEED: NONE  
 SERVO: OFF1 (DCBRAKE, NONE, OFF2, OFF3)  
 VECTOR: OFF1 (DCBRAKE, NONE, OFF2, OFF3)

**Acknowledge:** PULSE INHIBIT

**Cause:** The EnDat encoder fault word contains fault bits that have been set.  
 Fault value (r0949, interpret binary):  
 Bit 0: Lighting system failed.  
 Bit 1: Signal amplitude too low.  
 Bit 2: Position value incorrect.  
 Bit 3: Encoder power supply overvoltage condition.  
 Bit 4: Encoder power supply undervoltage condition.  
 Bit 5: Encoder power supply overcurrent condition.  
 Bit 6: The battery must be changed.

**Remedy:**

Re fault value, bit 0 = 1:  
Encoder is defective. Replace the encoder, where the motor encoder has a direct DRIVE-CLiQ socket: Replace the motor.

Re fault value, bit 1 = 1:  
Encoder is defective. Replace the encoder, where the motor encoder has a direct DRIVE-CLiQ socket: Replace the motor.

Re fault value, bit 2 = 1:  
Encoder is defective. Replace the encoder, where the motor encoder has a direct DRIVE-CLiQ socket: Replace the motor.

Re fault value, bit 3 = 1:  
5 V power supply voltage fault.  
When using an SMC: Check the plug-in cable between the encoder and SMC or replace the SMC.  
When a motor encoder with a direct DRIVE-CLiQ connection is used: Replace the motor.

Re fault value, bit 4 = 1:  
5 V power supply voltage fault.  
When using an SMC: Check the plug-in cable between the encoder and SMC or replace the SMC.  
When using a motor with DRIVE-CLiQ: Replace the motor.

Re fault value, bit 5 = 1:  
Encoder is defective. Replace the encoder, where the motor encoder has a direct DRIVE-CLiQ socket: Replace the motor.

Re fault value, bit 6 = 1:  
The battery must be changed - only for encoders with battery back-up.

Reaction upon N: NONE  
Acknowledge upon N: NONE  
Reaction upon A: NONE  
Acknowledge upon A: NONE

---

**F32112 (N, A) Encoder 2: The error bit is set in the serial protocol**

**Reaction:** A\_INFEED: NONE  
SERVO: OFF1 (DCBRAKE, NONE, OFF2, OFF3)  
VECTOR: OFF1 (DCBRAKE, NONE, OFF2, OFF3)

**Acknowledge:** PULSE INHIBIT

**Cause:** Serial communication protocol transfer error between the encoder and evaluation module SMCxx.  
Fault value (r0949, decimal):

**Remedy:** Re fault value:

Reaction upon N: NONE  
Acknowledge upon N: NONE  
Reaction upon A: NONE  
Acknowledge upon A: NONE

**F32115 (N, A) Encoder 2: Amplitude error track A or B (A<sup>2</sup> + B<sup>2</sup>)**

**Reaction:** A\_INFEED: NONE  
 SERVO: OFF1 (DCBRAKE, NONE, OFF2, OFF3)  
 VECTOR: OFF1 (DCBRAKE, NONE, OFF2, OFF3)

**Acknowledge:** PULSE INHIBIT

**Cause:** The amplitude (A<sup>2</sup> + B<sup>2</sup>) does not lie within the tolerance bandwidth (software monitoring function).  
 SMC20:  
 The nominal signal level of the encoder must lie in the range 375 mV to 600 mV (500 mV -25 % / +20 %).  
 On the other hand, the response threshold is < 230 mV (frequency characteristic).  
 SMC10:  
 The nominal signal level is at 2900 mV (2.0 Vrms). The response threshold is < 1070 mV.  
 Fault value (r0949, decimal):  
 Low word:  
 Signal level, track A (16 bits with sign).  
 High word:  
 Signal level, track B (16 bits with sign).  
 SMC20:  
 A signal level of 500 mV peak value corresponds to the numerical value 5333 hex = 21299 dec.  
 SMC10:  
 A signal level of 2900 mV peak value corresponds to the numerical value 6666 hex = 26214 dec.

**Remedy:**

- check that the encoder cables are routed in compliance with EMC.
- check the plug connections.
- replace the encoder or encoder cable.
- check the encoder module (e.g. contacts).
- with measuring systems without their own bearing system: Adjust the scanning head and check the bearing system of the measuring wheel.
- for measuring systems with their own bearing system: Ensure that the encoder housing is not subject to any axial force.

Reaction upon N: NONE  
 Acknowledge upon N: NONE  
 Reaction upon A: NONE  
 Acknowledge upon A: NONE

**F32116 (N, A) Encoder 2: Amplitude error, monitoring track A + B**

**Reaction:** A\_INFEED: NONE  
 SERVO: OFF1 (DCBRAKE, NONE, OFF2, OFF3)  
 VECTOR: OFF1 (DCBRAKE, NONE, OFF2, OFF3)

**Acknowledge:** IMMEDIATELY

**Cause:** The amplitude of the rectified encoder signals A and B is not within the tolerance bandwidth (hardware monitoring).  
 The nominal signal level of the encoder must lie in the range 375 mV to 600 mV (500 mV -25 % / +20 %).  
 On the other hand, the hardware response thresholds are at < 176 mV and > 1.35 V.  
 Fault value (r0949, decimal):  
 Low word: Signal level, track A (16 bits with sign).  
 High word: Signal level, track B (16 bits with sign).  
 A signal level of 500 mV corresponds to the numerical value 5333 hex = 21299 dec.  
 These analog values are not measured at the same time with the hardware fault output.

**Remedy:**

- check that the encoder cables are routed in compliance with EMC.
- check the plug connections.
- replace the encoder or encoder cable.
- check the encoder module (e.g. contacts).

Reaction upon N: NONE  
 Acknowledge upon N: NONE  
 Reaction upon A: NONE  
 Acknowledge upon A: NONE



---

<b>F32117 (N, A)</b>	<b>Encoder 2: Inversion error, signals A and B and R</b>
<b>Reaction:</b>	A_INFEED: NONE SERVO: OFF1 (DCBRAKE, NONE, OFF2, OFF3) VECTOR: OFF1 (DCBRAKE, NONE, OFF2, OFF3)
<b>Acknowledge:</b>	IMMEDIATELY
<b>Cause:</b>	For a square-wave signal encoder (TTL. bipolar. double ended) the A* and B* and R* signals are not inverted with respect to signals A and B and R.
<b>Remedy:</b>	Check the setting of p0405: p0405.2 = 1 is only possible if the encoder is connected at X520. Check the encoder/cable: Does the encoder supply TTL signals and the associated inverted signals?
Reaction upon N:	NONE
Acknowledge upon N:	NONE
Reaction upon A:	NONE
Acknowledge upon A:	NONE

---

<b>F32118 (N, A)</b>	<b>Encoder 2: Speed difference outside the tolerance range</b>
<b>Reaction:</b>	A_INFEED: NONE SERVO: OFF1 (DCBRAKE, NONE, OFF2, OFF3) VECTOR: OFF1 (DCBRAKE, NONE, OFF2, OFF3)
<b>Acknowledge:</b>	PULSE INHIBIT
<b>Cause:</b>	For an HTL/TTL encoder, the speed difference has exceeded the value in p0492 over several sampling cycles. Fault value (r0949, decimal): Only for internal Siemens troubleshooting.
<b>Remedy:</b>	- check the tachometer feeder cable for interruptions. - check the grounding of the tachometer shielding. - if required, increase the maximum speed difference per sampling cycle (p0492).
Reaction upon N:	NONE
Acknowledge upon N:	NONE
Reaction upon A:	NONE
Acknowledge upon A:	NONE

---

<b>F32120 (N, A)</b>	<b>Encoder 2: Power supply voltage</b>
<b>Reaction:</b>	A_INFEED: NONE SERVO: OFF1 (DCBRAKE, NONE, OFF2, OFF3) VECTOR: OFF1 (DCBRAKE, NONE, OFF2, OFF3)
<b>Acknowledge:</b>	PULSE INHIBIT
<b>Cause:</b>	Encoder power supply voltage fault. Note: If the encoder cables 6FX2002-2EQ00-.... and 6FX2002-2CH00-.... are interchanged, this can result in the encoder being destroyed because the pins of the operating voltage are reversed. Fault value (r0949, interpret binary): Bit 0: Undervoltage condition on the sense line (threshold 4.75 V). Bit 1: Encoder power supply voltage overcurrent condition (threshold 450 mA).
<b>Remedy:</b>	For fault value, bit 0 = 1: - correct encoder cable connected? - check the plug connections of the encoder cable. - SMC30: Check the parameterization (p0404.22). For fault value, bit 1 = 1: - correct encoder cable connected? - replace the encoder or encoder cable.
Reaction upon N:	NONE
Acknowledge upon N:	NONE

Reaction upon A: NONE  
 Acknowledge upon A: NONE

---

**F32121 (N, A) Encoder 2: Coarse position error**

**Reaction:** A\_INFEED: NONE  
 SERVO: OFF1 (NONE, OFF2, OFF3)  
 VECTOR: OFF1 (NONE, OFF2, OFF3)

**Acknowledge:** PULSE INHIBIT

**Cause:** For the actual value sensing, an error was detected on the module. As a result of this error, it must be assumed that the actual value sensing supplies an incorrect coarse position.

**Remedy:** Replace the motor with DRIVE-CLiQ or the appropriate Sensor Module.

Reaction upon N: NONE

Acknowledge upon N: NONE

Reaction upon A: NONE

Acknowledge upon A: NONE

---

**F32125 (N, A) Encoder 1: Amplitude error track A or B overcontrolled**

**Reaction:** A\_INFEED: NONE  
 SERVO: ENCODER (DCBRAKE, NONE)  
 VECTOR: ENCODER (DCBRAKE, NONE)

**Acknowledge:** PULSE INHIBIT

**Cause:** The amplitude (track A or B) does not lie within the tolerance bandwidth (software monitoring function).

SMC20:  
 The nominal signal level of the encoder must lie in the range 375 mV to 600 mV (500 mV -25 % / +20 %).  
 On the other hand, the response threshold is > 760 mV (frequency characteristic).

SMC10:  
 The nominal signal level is at 2900 mV (2.0 Vrms). The response threshold is > 3582 mV.  
 Fault value (r0949, decimal):

Low word:  
 Signal level, track A (16 bits with sign).

High word:  
 Signal level, track B (16 bits with sign).

SMC20:  
 A signal level of 500 mV peak value corresponds to the numerical value 5333 hex = 21299 dec.

SMC10:  
 A signal level of 2900 mV peak value corresponds to the numerical value 6666 hex = 26214 dec.  
 See also: p0491 (Motor encoder fault response ENCODER)

**Remedy:**

- check that the encoder cables are routed in compliance with EMC.
- replace the encoder or encoder cable.
- with measuring systems without their own bearing system: Adjust the scanning head and check the bearing system of the measuring wheel.

Reaction upon N: NONE

Acknowledge upon N: NONE

Reaction upon A: NONE

Acknowledge upon A: NONE

---

<b>F32129 (N, A)</b>	<b>Encoder 2: Position difference, hall sensor/track C/D and A/B too large</b>
<b>Reaction:</b>	A_INFEED: NONE SERVO: OFF1 (DCBRAKE, NONE, OFF2, OFF3) VECTOR: OFF1 (DCBRAKE, NONE, OFF2, OFF3)
<b>Acknowledge:</b>	PULSE INHIBIT
<b>Cause:</b>	The error of track C/D is greater than +/-15 ° mechanical or +/-60 ° electrical. One period of track C/D corresponds to 360 ° mechanical. One period of the Hall signal corresponds to 360 ° electrical. The monitoring responds if, for example, Hall sensors are connected as equivalent for the C/D tracks with the incorrect rotational sense or supply values that are not accurate enough. After the fine synchronization using one reference mark or 2 reference marks for distance-coded encoders, this fault is no longer initiated, but instead, Alarm A32429. Fault value (r0949, decimal): Measured deviation as mechanical angle (16 bits with sign, 182 dec corresponds to 1 °).
<b>Remedy:</b>	- track C or D not connected. - correct the direction of rotation of the Hall sensor possibly connected as equivalent for track C/D. - check that the encoder cables are routed in compliance with EMC. - check the adjustment of the Hall sensor.
Reaction upon N:	NONE
Acknowledge upon N:	NONE
Reaction upon A:	NONE
Acknowledge upon A:	NONE

---

<b>F32130 (N, A)</b>	<b>Encoder 2: Zero mark and position error from the coarse synchronization</b>
<b>Reaction:</b>	A_INFEED: NONE SERVO: OFF1 (DCBRAKE, NONE, OFF2, OFF3, STOP1, STOP2) VECTOR: OFF1 (DCBRAKE, NONE, OFF2, OFF3, STOP1, STOP2)
<b>Acknowledge:</b>	PULSE INHIBIT
<b>Cause:</b>	After initializing the pole position using track C/D, Hall signals or pole position identification routine, the zero mark was detected outside the permissible range. For distance-coded encoders, the test is carried-out after passing 2 zero marks. Fine synchronization was not carried-out. The deviation may be up to 18 ° mechanical or up to 60 ° electrical. Fault value (r0949, decimal): Normalization: 32768 = 180 ° High word: Mechanical zero mark position determined. If the initialization via a track C/D is selected in p0404, then it is checked whether the zero mark occurs in an angular range of +/-18 ° mechanical. Low word: Deviation of the zero mark from the expected position as electrical angle. If the correction of the commutation position with the zero mark is selected in p0404, then a difference of a maximum of +/- 60 ° electrical is permitted.
<b>Remedy:</b>	- check that the encoder cables are routed in compliance with EMC. - check the plug connections. - if the Hall sensor is used as an equivalent for track C/D, check the connection. - check the connection of track C or D. - replace the encoder or encoder cable.
Reaction upon N:	NONE
Acknowledge upon N:	NONE
Reaction upon A:	NONE
Acknowledge upon A:	NONE

<b>F32131 (N, A)</b>	<b>Encoder 2: Deviation, position incremental/absolute too large</b>
<b>Reaction:</b>	A_INFEED: NONE SERVO: OFF1 (DCBRAKE, NONE, OFF2, OFF3, STOP1, STOP2) VECTOR: OFF1 (DCBRAKE, NONE, OFF2, OFF3, STOP1, STOP2)
<b>Acknowledge:</b>	PULSE INHIBIT
<b>Cause:</b>	Absolute encoder: When cyclically reading the absolute position, an excessively high difference to the incremental position was detected. The absolute position that was read is rejected. Limit value for the deviation: - EnDat encoder: Is supplied from the encoder and is a minimum of 2 quadrants (e.g. EQI 1325 > 2 quadrants, EQN 1325 > 50 quadrants). - other encoders: 15 pulses = 60 quadrants. Fault value (r0949, decimal): Deviation in quadrants (1 pulse = 4 quadrants). Incremental encoder: When the zero pulse is passed, a deviation in the incremental position was detected.
<b>Remedy:</b>	- check that the encoder cables are routed in compliance with EMC. - check the plug connections. - replace the encoder or encoder cable. - check whether the coding disk is dirty or there are strong ambient magnetic fields.
Reaction upon N:	NONE
Acknowledge upon N:	NONE
Reaction upon A:	NONE
Acknowledge upon A:	NONE

<b>F32150 (N, A)</b>	<b>Encoder 2: Initialization error</b>
<b>Reaction:</b>	A_INFEED: NONE SERVO: OFF1 (DCBRAKE, NONE, OFF2, OFF3, STOP1, STOP2) VECTOR: OFF1 (DCBRAKE, NONE, OFF2, OFF3, STOP1, STOP2)
<b>Acknowledge:</b>	PULSE INHIBIT
<b>Cause:</b>	Encoder functionality selected in p0404 is not operating correctly. Fault value (r0949, interpret hexadecimal): The fault value is a bit field. Every set bit indicates functionality that is faulted. The bit assignment corresponds to that of p0404 (e.g. bit 5 set: Error track C/D).
<b>Remedy:</b>	- Check that p0404 is correctly set. - check the encoder type used (incremental/absolute value) and for SMCxx, the encoder cable. - if relevant, note additional fault/error messages that describe the fault in detail.
Reaction upon N:	NONE
Acknowledge upon N:	NONE
Reaction upon A:	NONE
Acknowledge upon A:	NONE

<b>A32400 (F, N)</b>	<b>Encoder 2: Alarm threshold, zero mark distance error</b>
<b>Reaction:</b>	NONE
<b>Acknowledge:</b>	NONE
<b>Cause:</b>	The measured zero mark distance does not correspond to the parameterized zero mark distance. For distance-coded encoders, the zero mark distance is determined from zero marks detected pairs. This means that if a zero mark is missing, depending on the pair generation, this cannot result in a fault and also has no effect in the system. The zero mark distance for the zero mark monitoring is set in p0425 (rotary encoder) or p0424 (linear encoder). Alarm value (r2124, decimal): Last measured zero mark distance in increments (4 increments = 1 encoder pulse). The sign designates the direction of motion when detecting the zero mark distance.

**Remedy:**

- check that the encoder cables are routed in compliance with EMC.
- check the plug connections.
- . check the encoder type (encoder with equidistant zero marks).
- adapt the parameter for the distance between zero marks (p0424, p0425).
- replace the encoder or encoder cable.

Reaction upon F: A\_INFEED: NONE (OFF1, OFF2)  
 SERVO: NONE (DCBRAKE, OFF1, OFF2, OFF3, STOP1, STOP2)  
 VECTOR: NONE (DCBRAKE, OFF1, OFF2, OFF3, STOP1, STOP2)

Acknowledge upon F: IMMEDIATELY

Reaction upon N: NONE

Acknowledge upon N: NONE

**A32401 (F, N) Encoder 2: Alarm threshold, zero marked failed**

**Reaction:** NONE

**Acknowledge:** NONE

**Cause:** The 1.5 x parameterized zero mark distance was exceeded.  
 The zero mark distance for the zero mark monitoring is set in p0425 (rotary encoder) or p0424 (linear encoder).  
 Alarm value (r2124, decimal):  
 Number of increments after POWER ON or since the last zero mark that was detected (4 increments = 1 encoder pulse).

**Remedy:**

- check that the encoder cables are routed in compliance with EMC.
- check the plug connections.
- . check the encoder type (encoder with equidistant zero marks).
- adapt the parameter for the clearance between zero marks (p0425).
- replace the encoder or encoder cable.

Reaction upon F: A\_INFEED: NONE (OFF1, OFF2)  
 SERVO: NONE (DCBRAKE, OFF1, OFF2, OFF3, STOP1, STOP2)  
 VECTOR: NONE (DCBRAKE, OFF1, OFF2, OFF3, STOP1, STOP2)

Acknowledge upon F: IMMEDIATELY

Reaction upon N: NONE

Acknowledge upon N: NONE

**F32405 (N, A) Encoder 2: Encoder evaluation temperature too high**

**Reaction:** A\_INFEED: NONE (OFF1, OFF2)  
 SERVO: NONE (DCBRAKE, OFF1, OFF2, OFF3, STOP1, STOP2)  
 VECTOR: NONE (DCBRAKE, OFF1, OFF2, OFF3, STOP1, STOP2)

**Acknowledge:** IMMEDIATELY (POWER ON)

**Cause:** The encoder evaluation for a motor with DRIVE-CLiQ has detected an excessively high temperature.  
 The fault threshold is 125 ° C.  
 Alarm value (r2124, decimal):  
 Measured board/module temperature in 0.1 °C.

**Remedy:** Reduce the ambient temperature for the DRIVE-CLiQ connection of the motor.

Reaction upon N: NONE

Acknowledge upon N: NONE

Reaction upon A: NONE

Acknowledge upon A: NONE

<b>A32410 (F, N)</b>	<b>Encoder 2: Serial communications</b>
<b>Reaction:</b>	NONE
<b>Acknowledge:</b>	NONE
<b>Cause:</b>	<p>Serial communication protocol transfer error between the encoder and evaluation module.</p> <p>Alarm value (r2124, interpret binary):</p> <p>Bit 0: Alarm bit in the position protocol.</p> <p>Bit 1: Incorrect quiescent level on the data line.</p> <p>Bit 2: Encoder does not respond (does not supply a start bit within 50 ms).</p> <p>Bit 3: CRC error: The checksum in the protocol from the encoder does not match the data.</p> <p>Bit 4: Encoder acknowledgement error: The encoder incorrectly understood the task (request) or cannot execute it.</p> <p>Bit 5: Internal error in the serial driver: An illegal mode command was requested.</p> <p>Bit 6: Timeout with cyclically reading.</p> <p>Bit 8: Protocol is too long (e.g. &gt; 64 bits).</p> <p>Bit 9: Receive buffer overflow.</p> <p>Bit 10: Frame error when reading twice.</p> <p>Bit 11: Parity error.</p> <p>Bit 12: Data line signal level error during the monoflop time.</p>
<b>Remedy:</b>	<ul style="list-style-type: none"> <li>- check that the encoder cables are routed in compliance with EMC.</li> <li>- check the plug connections.</li> <li>- replace the encoder.</li> </ul>
Reaction upon F:	<p>A_INFEED: NONE (OFF1, OFF2)</p> <p>SERVO: NONE (DCBRAKE, OFF1, OFF2, OFF3, STOP1, STOP2)</p> <p>VECTOR: NONE (DCBRAKE, OFF1, OFF2, OFF3, STOP1, STOP2)</p>
Acknowledge upon F:	IMMEDIATELY
Reaction upon N:	NONE
Acknowledge upon N:	NONE

<b>A32411 (F, N)</b>	<b>Encoder 2: EnDat encoder signals alarms</b>
<b>Reaction:</b>	NONE
<b>Acknowledge:</b>	NONE
<b>Cause:</b>	<p>The error word of the EnDat encoder has alarm bits that have been set.</p> <p>Alarm value (r2124, interpret binary):</p> <p>Bit 0: Frequency exceeded (speed too high).</p> <p>Bit 1: Temperature exceeded.</p> <p>Bit 2: Control reserve, lighting system exceeded.</p> <p>Bit 3: Battery discharged.</p> <p>Bit 4: Reference point passed.</p>
<b>Remedy:</b>	Replace encoder.
Reaction upon F:	<p>A_INFEED: NONE (OFF1, OFF2)</p> <p>SERVO: NONE (DCBRAKE, OFF1, OFF2, OFF3, STOP1, STOP2)</p> <p>VECTOR: NONE (DCBRAKE, OFF1, OFF2, OFF3, STOP1, STOP2)</p>
Acknowledge upon F:	IMMEDIATELY
Reaction upon N:	NONE
Acknowledge upon N:	NONE

---

<b>A32414 (F, N)</b>	<b>Encoder 2: Amplitude error track C or D (C<sup>2</sup> + D<sup>2</sup>)</b>
<b>Reaction:</b>	NONE
<b>Acknowledge:</b>	NONE
<b>Cause:</b>	<p>The amplitude (C<sup>2</sup> + D<sup>2</sup>) of track C or D of the encoder or from the Hall signals, is not within the tolerance bandwidth.</p> <p>The nominal signal must be in the range 375 mV to 600 mV (500 mV -25 % / +20 %).</p> <p>On the other hand, the response thresholds are &lt; 230 mV and &gt; 750 mV (frequency characteristic).</p> <p>This fault also occurs if the A/D converter is overcontrolled.</p> <p>If the amplitude is not within the tolerance bandwidth, then it cannot be used to initialize the start position.</p> <p>Alarm value (r2124, decimal):</p> <p>Low word: Signal level, track C (16 bits with sign).</p> <p>High word: Signal level, track D (16 bits with sign).</p> <p>A signal level of 500 mV corresponds to the numerical value 5333 hex = 21299 dec.</p>
<b>Remedy:</b>	<ul style="list-style-type: none"> <li>- check that the encoder cables are routed in compliance with EMC.</li> <li>- check the plug connections.</li> <li>- replace the encoder or encoder cable.</li> <li>- check the encoder module (e.g. contacts).</li> <li>- check the Hall sensor box</li> </ul>
Reaction upon F:	<p>A_INFEED: NONE (OFF1, OFF2)</p> <p>SERVO: NONE (DCBRAKE, OFF1, OFF2, OFF3, STOP1, STOP2)</p> <p>VECTOR: NONE (DCBRAKE, OFF1, OFF2, OFF3, STOP1, STOP2)</p>
Acknowledge upon F:	IMMEDIATELY
Reaction upon N:	NONE
Acknowledge upon N:	NONE

---

<b>N32415 (F, A)</b>	<b>Encoder 2: Amplitude alarm track A or B (A<sup>2</sup> + B<sup>2</sup>)</b>
<b>Reaction:</b>	NONE
<b>Acknowledge:</b>	NONE
<b>Cause:</b>	<p>The amplitude (A<sup>2</sup> + B<sup>2</sup>) of track A or B is not within the tolerance bandwidth.</p> <p>SMC20: The nominal signal level is at 500 mV (500 mV -25 % / +20 %). The response threshold is &lt; 300 mV.</p> <p>SMC10: The nominal signal level is at 2900 mV (2.0 Vrms). The response threshold is &lt; 1414 mV (1.0 Vrms).</p> <p>Alarm value (r2124, decimal):</p> <p>Low word: Amplitude square root(A*A + B*B).</p> <p>SMC20: A signal level of 500 mV peak value corresponds to the numerical value 299A hex = 10650 dec.</p> <p>SMC10: A signal level of 2900 mV peak value corresponds to the numerical value 3333 hex = 13107 dec.</p> <p>High word: Angle 0 to 65535 corresponds to 0 to 360 degrees of the fine position. Zero degrees is at the negative zero crossover of track B.</p>
<b>Remedy:</b>	<ul style="list-style-type: none"> <li>- check the speed range, frequency characteristic (amplitude characteristic) of the measuring equipment is not sufficient for the speed range.</li> <li>- check that the encoder cables are routed in compliance with EMC.</li> <li>- check the plug connections.</li> <li>- replace the encoder or encoder cable.</li> <li>- check the encoder module (e.g. contacts).</li> <li>- dirty code disk</li> <li>- aged lighting system.</li> </ul>
Reaction upon F:	<p>A_INFEED: NONE (OFF1, OFF2)</p> <p>SERVO: NONE (DCBRAKE, OFF1, OFF2, OFF3, STOP1, STOP2)</p> <p>VECTOR: NONE (DCBRAKE, OFF1, OFF2, OFF3, STOP1, STOP2)</p>
Acknowledge upon F:	IMMEDIATELY
Reaction upon A:	NONE
Acknowledge upon A:	NONE

<b>A32418 (F, N)</b>	<b>Encoder 2: Speed difference per sampling rate exceeded</b>
<b>Reaction:</b>	NONE
<b>Acknowledge:</b>	NONE
<b>Cause:</b>	For an HTL/TTL encoder, the speed difference between two sampling cycles has exceeded the value in p0492. Alarm value (r2124, decimal): Only for internal Siemens troubleshooting.
<b>Remedy:</b>	- check the tachometer feeder cable for interruptions. - check the grounding of the tachometer shielding. - if required, increase the setting of p0492.
Reaction upon F:	A_INFEED: NONE (OFF1, OFF2) SERVO: NONE (DCBRAKE, OFF1, OFF2, OFF3, STOP1, STOP2) VECTOR: NONE (DCBRAKE, OFF1, OFF2, OFF3, STOP1, STOP2)
Acknowledge upon F:	IMMEDIATELY
Reaction upon N:	NONE
Acknowledge upon N:	NONE
<b>A32419 (F, N)</b>	<b>Encoder 2: Track A or B outside the tolerance range</b>
<b>Reaction:</b>	NONE
<b>Acknowledge:</b>	NONE
<b>Cause:</b>	The amplitude, phase or offset correction for track A or B is at the limit. Amplitude error correction: Amplitude B / Amplitude A = 0.78 ... 1.27 Phase: <84 degrees or >96 degrees SMC20: Offset correction: +/-140 mV SMC10: Offset correction: +/-650 mV Alarm value (r2124, interpret hexadecimal): xxx1: Minimum of the offset correction, track B xxx2: Maximum of the offset correction, track B xx1x: Minimum of the offset correction, track A xx2x: Maximum of the offset correction, track A x1xx: Minimum of the amplitude correction, track B/A x2xx: Maximum of the amplitude correction, track B/A 1xxx: Minimum of the phase error correction 2xxx: Maximum of the phase error correction
<b>Remedy:</b>	- check mechanical mounting tolerances for encoders without their own bearings (e.g. toothed-wheel encoders). - check the plug connections (also the transition resistance). - check the encoder signals. - replace the encoder or encoder cable.
Reaction upon F:	A_INFEED: NONE (OFF1, OFF2) SERVO: NONE (DCBRAKE, OFF1, OFF2, OFF3, STOP1, STOP2) VECTOR: NONE (DCBRAKE, OFF1, OFF2, OFF3, STOP1, STOP2)
Acknowledge upon F:	IMMEDIATELY
Reaction upon N:	NONE
Acknowledge upon N:	NONE
<b>A32429 (F, N)</b>	<b>Encoder 2: Position difference, hall sensor/track C/D and A/B too large</b>
<b>Reaction:</b>	NONE
<b>Acknowledge:</b>	NONE
<b>Cause:</b>	The error of track C/D is greater than +/-15 ° mechanical or +/-60 ° electrical. One period of track C/D corresponds to 360 ° mechanical. One period of the Hall signal corresponds to 360 ° electrical. The monitoring responds if, for example, Hall sensors are connected as equivalent for the C/D tracks with the incorrect rotational sense or supply values that are not accurate enough. Alarm value (r2124, decimal): Measured deviation as mechanical angle (16 bits with sign, 182 dec corresponds to 1 °).



**Remedy:**

- track C or D not connected.
- correct the direction of rotation of the Hall sensor possibly connected as equivalent for track C/D.
- check that the encoder cables are routed in compliance with EMC.
- check the adjustment of the Hall sensor.

Reaction upon F: A\_INFEED: NONE (OFF1, OFF2)  
 SERVO: NONE (DCBRAKE, OFF1, OFF2, OFF3, STOP1, STOP2)  
 VECTOR: NONE (DCBRAKE, OFF1, OFF2, OFF3, STOP1, STOP2)

Acknowledge upon F: IMMEDIATELY

Reaction upon N: NONE

Acknowledge upon N: NONE

**A32431 (F, N) Encoder 2: Deviation, position incremental/absolute too large**

**Reaction:** NONE

**Acknowledge:** NONE

**Cause:** Absolute encoder: When cyclically reading the absolute position, an excessively high difference to the incremental position was detected.  
 Alarm value (r2124, decimal):  
 Deviation in quadrants (1 pulse = 4 quadrants).  
 Incremental encoder: When the zero pulse is passed, a deviation in the incremental position was detected.

**Remedy:**

- check that the encoder cables are routed in compliance with EMC.
- check the plug connections.
- replace the encoder or encoder cable.
- coding disk dirty or strong magnetic fields.

Reaction upon F: A\_INFEED: NONE (OFF1, OFF2)  
 SERVO: NONE (DCBRAKE, OFF1, OFF2, OFF3, STOP1, STOP2)  
 VECTOR: NONE (DCBRAKE, OFF1, OFF2, OFF3, STOP1, STOP2)

Acknowledge upon F: IMMEDIATELY

Reaction upon N: NONE

Acknowledge upon N: NONE

**F32501 (N, A) Encoder 2: Position tracking encoder position outside tolerance window**

**Reaction:** A\_INFEED: NONE  
 SERVO: OFF1 (NONE, OFF2, OFF3)  
 VECTOR: OFF1 (NONE, OFF2, OFF3)

**Acknowledge:** IMMEDIATELY

**Cause:** When powered-down, the drive/encoder was moved through a distance greater than what was set in the tolerance window.  
 See also: p0413 (Measuring gearbox, position tracking tolerance window)

**Remedy:** Re-adjust the drive.

Reaction upon N: NONE

Acknowledge upon N: NONE

Reaction upon A: NONE

Acknowledge upon A: NONE

---

**F32502 (N, A) Encoder 2: Encoder with measuring gear, without valid signals**

**Reaction:** A\_INFEED: OFF1 (OFF2)  
SERVO: OFF1 (OFF2, OFF3)  
VECTOR: OFF1 (OFF2, OFF3)

**Acknowledge:** IMMEDIATELY

**Cause:** The encoder with measuring gear no longer provides any valid signals.

**Remedy:** It must be ensured that all of the encoders, with mounted measuring gear, provide valid actual values in operation.

Reaction upon N: NONE  
Acknowledge upon N: NONE  
Reaction upon A: NONE  
Acknowledge upon A: NONE

---

**F32801 (N, A) Encoder 2 DRIVE-CLiQ: Sign-of-life missing**

**Reaction:** A\_INFEED: OFF2 (NONE)  
SERVO: OFF1 (DCBRAKE, NONE, OFF2, OFF3)  
VECTOR: OFF1 (DCBRAKE, NONE, OFF2, OFF3)

**Acknowledge:** IMMEDIATELY

**Cause:** DRIVE-CLiQ communications error between the Control Unit and the encoder involved.  
Fault value (r0949, interpret hexadecimal):  
0A: The sign-of-life bit in the receive telegram is not set.

**Remedy:** - check the electrical cabinet design and cable routing for EMC compliance.  
- replace the component involved.  
See also: p9916 (DRIVE-CLiQ data transfer error, shutdown threshold, slave)

Reaction upon N: NONE  
Acknowledge upon N: NONE  
Reaction upon A: NONE  
Acknowledge upon A: NONE

---

**F32802 (N, A) Encoder 2: Time slice overflow**

**Reaction:** A\_INFEED: OFF2 (NONE)  
SERVO: OFF1 (DCBRAKE, NONE, OFF2, OFF3)  
VECTOR: OFF1 (DCBRAKE, NONE, OFF2, OFF3)

**Acknowledge:** IMMEDIATELY

**Cause:** Time slice overflow, encoder 2.  
Fault value (r0949, decimal):  
9: Time slice overflow of the fast (current controller clock cycle) time slice.  
10: Time slice overflow of the average time slice.  
12: Time slice overflow of the slow time slice.  
999: Timeout when waiting for SYNO, e.g. unexpected return to non-cyclic operation.

**Remedy:** Reduce the current controller frequency.

Reaction upon N: NONE  
Acknowledge upon N: NONE  
Reaction upon A: NONE  
Acknowledge upon A: NONE

---

---

**F32804 (N, A) Encoder 2: CRC CODE RAM**

**Reaction:** A\_INFEED: OFF2 (NONE)  
SERVO: OFF1 (DCBRAKE, NONE, OFF2, OFF3)  
VECTOR: OFF1 (DCBRAKE, NONE, OFF2, OFF3)

**Acknowledge:** IMMEDIATELY

**Cause:** The checksum via the CODE-RAM of the Sensor Module has changed in operation.  
Fault value (r0949, interpret hexadecimal):  
Difference between the checksum at POWER ON and the actual checksum.

**Remedy:** Hardware defect: Replace the Sensor Module.  
Firmware error: If required, upgrade the firmware.

Reaction upon N: NONE  
Acknowledge upon N: NONE  
Reaction upon A: NONE  
Acknowledge upon A: NONE

---

**F32805 (N, A) Encoder 2: EPROM checksum error**

**Reaction:** A\_INFEED: OFF2 (NONE)  
SERVO: OFF1 (DCBRAKE, NONE, OFF2, OFF3)  
VECTOR: OFF1 (DCBRAKE, NONE, OFF2, OFF3)

**Acknowledge:** IMMEDIATELY

**Cause:** Internal parameter data is corrupted.  
Fault value (r0949, interpret hexadecimal):  
01: EEPROM access error.  
02: Too many blocks in the EEPROM.

**Remedy:** Replace the module.

Reaction upon N: NONE  
Acknowledge upon N: NONE  
Reaction upon A: NONE  
Acknowledge upon A: NONE

---

**F32806 (N, A) Encoder 2: Initialization error**

**Reaction:** A\_INFEED: OFF2 (NONE)  
SERVO: OFF1 (DCBRAKE, NONE, OFF2, OFF3)  
VECTOR: OFF1 (DCBRAKE, NONE, OFF2, OFF3)

**Acknowledge:** PULSE INHIBIT

**Cause:** The encoder was not successfully initialized.  
Fault value (r0949, interpret hexadecimal):  
1, 2, 3: Encoder initialization with the motor rotating.

**Remedy:** Acknowledge the fault.

Reaction upon N: NONE  
Acknowledge upon N: NONE  
Reaction upon A: NONE  
Acknowledge upon A: NONE

---

**F32812 (N, A) Encoder 2: A cycle requested from the CU or RX/TX timing is not supported**

**Reaction:** OFF2  
**Acknowledge:** IMMEDIATELY  
**Cause:** A cycle requested from the CU or RX/TX timing is not supported  
 Fault value (r0949):  
 0: Application cycle is not supported.  
 1: DQ cycle is not supported.  
 2: Clearance between RX and TX instants in time too low.  
 3: TX instant in time too early.

**Remedy:**  
 Reaction upon N: NONE  
 Acknowledge upon N: NONE  
 Reaction upon A: NONE  
 Acknowledge upon A: NONE

---

**F32820 (N, A) Encoder 2 DRIVE-CLiQ: Telegram error**

**Reaction:** A\_INFEED: OFF2  
 SERVO: OFF1 (DCBRAKE, NONE, OFF2, OFF3)  
 VECTOR: OFF1 (DCBRAKE, NONE, OFF2, OFF3)

**Acknowledge:** IMMEDIATELY  
**Cause:** DRIVE-CLiQ communications error between the Control Unit and the encoder involved.  
 Fault value (r0949, interpret hexadecimal):  
 01: CRC error.  
 02: Telegram is shorter than specified in the length byte or in the receive list.  
 03: Telegram is longer than specified in the length byte or in the receive list.  
 04: The length of the receive telegram does not match the receive list.  
 05: The type of the receive telegram does not match the receive list.  
 06: The address of the encoder in the telegram and in the receive list do not match.  
 07: The encoder expects a SYNC telegram, but the receive telegram is not a SYNC telegram.  
 08: The encoder does not expect a SYNC telegram, but the receive telegram is a SYNC telegram.  
 09: The error bit in the receive telegram is set.  
 10: The receive telegram is too early.

**Remedy:**  
 - carry-out a POWER ON.  
 - check the electrical cabinet design and cable routing for EMC compliance.  
 - check the DRIVE-CLiQ wiring (interrupted cable, contacts, ...).  
 See also: p9916 (DRIVE-CLiQ data transfer error, shutdown threshold, slave)

Reaction upon N: NONE  
 Acknowledge upon N: NONE  
 Reaction upon A: NONE  
 Acknowledge upon A: NONE

---

**F32835 (N, A) Encoder 2 DRIVE-CLiQ: Cyclic data transfer error**

**Reaction:** A\_INFEED: OFF2  
 SERVO: OFF1 (DCBRAKE, NONE, OFF2, OFF3)  
 VECTOR: OFF1 (DCBRAKE, NONE, OFF2, OFF3)

**Acknowledge:** IMMEDIATELY  
**Cause:** DRIVE-CLiQ communications error between the Control Unit and the encoder involved. The nodes do not send and receive in synchronism.  
 Fault value (r0949, interpret hexadecimal):  
 21: The cyclic telegram has not been received.  
 22: Timeout in the telegram receive list.  
 40: Timeout in the telegram send list.

**Remedy:**  
 - carry-out a POWER ON.  
 - replace the component involved.  
 See also: p9916 (DRIVE-CLiQ data transfer error, shutdown threshold, slave)

Reaction upon N: NONE  
 Acknowledge upon N: NONE  
 Reaction upon A: NONE  
 Acknowledge upon A: NONE

**F32836 (N, A) Encoder 2 DRIVE-CLiQ: Send error for DRIVE-CLiQ data**

**Reaction:** A\_INFEED: OFF2  
 SERVO: OFF1 (DCBRAKE, NONE, OFF2, OFF3)  
 VECTOR: OFF1 (DCBRAKE, NONE, OFF2, OFF3)

**Acknowledge:** IMMEDIATELY

**Cause:** DRIVE-CLiQ communications error between the Control Unit and the encoder involved. Data were not able to be sent.  
 Fault value (r0949, interpret hexadecimal):  
 41: Telegram type does not match send list.

**Remedy:** Carry-out a POWER ON.

Reaction upon N: NONE  
 Acknowledge upon N: NONE  
 Reaction upon A: NONE  
 Acknowledge upon A: NONE

**F32837 (N, A) Encoder 2 DRIVE-CLiQ: Component fault**

**Reaction:** A\_INFEED: OFF2  
 SERVO: OFF1 (DCBRAKE, NONE, OFF2, OFF3)  
 VECTOR: OFF1 (DCBRAKE, NONE, OFF2, OFF3)

**Acknowledge:** IMMEDIATELY

**Cause:** Fault detected on the DRIVE-CLiQ component involved. Faulty hardware cannot be excluded.  
 Fault value (r0949, interpret hexadecimal):  
 20: Error in the telegram header.  
 23: Receive error: The telegram buffer memory contains an error.  
 42: Send error: The telegram buffer memory contains an error.  
 43: Send error: The telegram buffer memory contains an error.

**Remedy:** - check the DRIVE-CLiQ wiring (interrupted cable, contacts, ...).  
 - check the electrical cabinet design and cable routing for EMC compliance.  
 - if required, use another DRIVE-CLiQ socket (p9904).  
 - replace the component involved.

Reaction upon N: NONE  
 Acknowledge upon N: NONE  
 Reaction upon A: NONE  
 Acknowledge upon A: NONE

**F32845 (N, A) Encoder 2 DRIVE-CLiQ: Cyclic data transfer error**

**Reaction:** A\_INFEED: OFF2  
 SERVO: OFF1 (DCBRAKE, NONE, OFF2, OFF3)  
 VECTOR: OFF1 (DCBRAKE, NONE, OFF2, OFF3)

**Acknowledge:** IMMEDIATELY

**Cause:** DRIVE-CLiQ communications error between the Control Unit and the encoder involved.  
 Fault value (r0949, interpret hexadecimal):  
 0B: Synchronization error during alternating cyclic data transfer.

**Remedy:** Carry-out a POWER ON.  
 See also: p9916 (DRIVE-CLiQ data transfer error, shutdown threshold, slave)

Reaction upon N: NONE  
 Acknowledge upon N: NONE  
 Reaction upon A: NONE  
 Acknowledge upon A: NONE

---

**F32850 (N, A) Encoder 2: Sensor Module, internal software error**

**Reaction:** A\_INFEED: OFF2 (NONE)  
 SERVO: OFF1 (DCBRAKE, NONE, OFF2, OFF3)  
 VECTOR: OFF1 (DCBRAKE, NONE, OFF2, OFF3)

**Acknowledge:** POWER ON

**Cause:** Internal software error in the Sensor Module of encoder 2.  
 Fault value (r0949, decimal):  
 1: Background time slice is blocked.  
 2: Checksum over the code memory is not OK.  
 10000: OEM memory of the EnDat encoder contains data that cannot be interpreted.

**Remedy:**  
 - replace the Sensor Module.  
 - if required, upgrade the firmware in the Sensor Module.  
 - contact the Hotline.

Reaction upon N: NONE  
 Acknowledge upon N: NONE  
 Reaction upon A: NONE  
 Acknowledge upon A: NONE

---

**F32851 (N, A) CU DRIVE-CLiQ: Sign-of-life missing**

**Reaction:** A\_INFEED: NONE (OFF1, OFF2)  
 SERVO: OFF1 (DCBRAKE, NONE, OFF2, OFF3)  
 VECTOR: OFF1 (DCBRAKE, NONE, OFF2, OFF3)

**Acknowledge:** IMMEDIATELY

**Cause:** A DRIVE-CLiQ communications error has occurred between the Control Unit and the Sensor Module (encoder 2) involved. The DRIVE-CLiQ component did not set the sign of life to the Control Unit.  
 Fault value (r0949, interpret hexadecimal):  
 0A: The sign-of-life bit in the receive telegram is not set.

**Remedy:** Upgrade the firmware of the component involved.

Reaction upon N: NONE  
 Acknowledge upon N: NONE  
 Reaction upon A: NONE  
 Acknowledge upon A: NONE

---

<b>F32860 (N, A)</b>	<b>CU DRIVE-CLiQ: Telegram error</b>
<b>Reaction:</b>	A_INFEED: NONE (OFF1, OFF2) SERVO: OFF1 (DCBRAKE, NONE, OFF2, OFF3) VECTOR: OFF1 (DCBRAKE, NONE, OFF2, OFF3)
<b>Acknowledge:</b>	IMMEDIATELY
<b>Cause:</b>	DRIVE-CLiQ communications error between the Control Unit and the encoder involved. Fault value (r0949, interpret hexadecimal): 11: CRC error and the receive telegram is too early. 01: CRC error. 12: The telegram is shorter than that specified in the length byte or in the receive list and the receive telegram is too early. 02: Telegram is shorter than specified in the length byte or in the receive list. 13: The telegram is longer than that specified in the length byte or in the receive list and the receive telegram is too early. 03: Telegram is longer than specified in the length byte or in the receive list. 14: The length of the receive telegram does not match the receive list and the receive telegram is too early. 04: The length of the receive telegram does not match the receive list. 15: The type of the receive telegram does not match the receive list and the receive telegram is too early. 05: The type of the receive telegram does not match the receive list. 16: The address of the encoder in the telegram and in the receive list does not match and the receive telegram is too early. 06: The address of the encoder in the telegram and in the receive list do not match. 19: The error bit in the receive telegram is set and the receive telegram is too early. 09: The error bit in the receive telegram is set. 10: The receive telegram is too early.
<b>Remedy:</b>	- carry-out a POWER ON. - check the electrical cabinet design and cable routing for EMC compliance. - check the DRIVE-CLiQ wiring (interrupted cable, contacts, ...). See also: p9915 (DRIVE-CLiQ data transfer error, shutdown threshold, master)
Reaction upon N:	NONE
Acknowledge upon N:	NONE
Reaction upon A:	NONE
Acknowledge upon A:	NONE

---

<b>F32885 (N, A)</b>	<b>CU DRIVE-CLiQ: Cyclic data transfer error</b>
<b>Reaction:</b>	A_INFEED: NONE (OFF1, OFF2) SERVO: OFF1 (DCBRAKE, NONE, OFF2, OFF3) VECTOR: OFF1 (DCBRAKE, NONE, OFF2, OFF3)
<b>Acknowledge:</b>	IMMEDIATELY
<b>Cause:</b>	DRIVE-CLiQ communications error between the Control Unit and the encoder involved. The nodes do not send and receive in synchronism. Fault value (r0949, interpret hexadecimal): 1A: Sign-of-life bit in the receive telegram not set and the receive telegram is too early. 21: The cyclic telegram has not been received. 22: Timeout in the telegram receive list. 40: Timeout in the telegram send list. 62: Error at the transition to cyclic operation.
<b>Remedy:</b>	- check the power supply voltage of the component involved. - carry-out a POWER ON. - replace the component involved. See also: p9915 (DRIVE-CLiQ data transfer error, shutdown threshold, master)
Reaction upon N:	NONE
Acknowledge upon N:	NONE
Reaction upon A:	NONE
Acknowledge upon A:	NONE

**F32886 (N, A) CU DRIVE-CLiQ: Error when sending DRIVE-CLiQ data**

**Reaction:** A\_INFEED: NONE (OFF1, OFF2)  
 SERVO: OFF1 (DCBRAKE, NONE, OFF2, OFF3)  
 VECTOR: OFF1 (DCBRAKE, NONE, OFF2, OFF3)

**Acknowledge:** IMMEDIATELY

**Cause:** DRIVE-CLiQ communications error between the Control Unit and the encoder involved. Data were not able to be sent.  
 Fault value (r0949, interpret hexadecimal):  
 41: Telegram type does not match send list.

**Remedy:** Carry-out a POWER ON.

Reaction upon N: NONE  
 Acknowledge upon N: NONE  
 Reaction upon A: NONE  
 Acknowledge upon A: NONE

**F32887 (N, A) CU DRIVE-CLiQ: Component fault**

**Reaction:** A\_INFEED: NONE (OFF1, OFF2)  
 SERVO: OFF1 (DCBRAKE, NONE, OFF2, OFF3)  
 VECTOR: OFF1 (DCBRAKE, NONE, OFF2, OFF3)

**Acknowledge:** IMMEDIATELY

**Cause:** Fault detected on the DRIVE-CLiQ component involved. Faulty hardware cannot be excluded.  
 Fault value (r0949, interpret hexadecimal):  
 20: Error in the telegram header.  
 23: Receive error: The telegram buffer memory contains an error.  
 42: Send error: The telegram buffer memory contains an error.  
 43: Send error: The telegram buffer memory contains an error.  
 60: Response received too late during runtime measurement.  
 61: Time taken to exchange characteristic data too long.

**Remedy:** - check the DRIVE-CLiQ wiring (interrupted cable, contacts, ...).  
 - check the electrical cabinet design and cable routing for EMC compliance.  
 - if required, use another DRIVE-CLiQ socket (p9904).  
 - replace the component involved.

Reaction upon N: NONE  
 Acknowledge upon N: NONE  
 Reaction upon A: NONE  
 Acknowledge upon A: NONE

**F32895 (N, A) CU DRIVE-CLiQ: Cyclic data transfer error**

**Reaction:** A\_INFEED: NONE (OFF1, OFF2)  
 SERVO: OFF1 (DCBRAKE, NONE, OFF2, OFF3)  
 VECTOR: OFF1 (DCBRAKE, NONE, OFF2, OFF3)

**Acknowledge:** IMMEDIATELY

**Cause:** DRIVE-CLiQ communications error between the Control Unit and the encoder involved.  
 Fault value (r0949, interpret hexadecimal):  
 0B: Synchronization error during alternating cyclic data transfer.

**Remedy:** Carry-out a POWER ON.  
 See also: p9915 (DRIVE-CLiQ data transfer error, shutdown threshold, master)

Reaction upon N: NONE  
 Acknowledge upon N: NONE  
 Reaction upon A: NONE  
 Acknowledge upon A: NONE



---

**F32896 (N, A) CU DRIVE-CLiQ: Inconsistent component characteristics**

**Reaction:** A\_INFEED: NONE (OFF1, OFF2)  
SERVO: OFF2 (DCBRAKE, NONE, OFF1, OFF3, STOP1, STOP2)  
VECTOR: OFF2 (DCBRAKE, NONE, OFF1, OFF3, STOP1, STOP2)

**Acknowledge:** IMMEDIATELY

**Cause:** The properties of the DRIVE-CLiQ component, specified by the fault value, have changed in an incompatible fashion with respect to the properties when booted. One cause can be, e.g. that a DRIVE-CLiQ cable or DRIVE-CLiQ component has been replaced.  
Fault value (r0949, decimal):  
Component ID.

**Remedy:** - when replacing cables, only use cables with the same length as the original cables.  
- when replacing components, use the same components and firmware releases.  
- carry-out a POWER ON.

Reaction upon N: NONE  
Acknowledge upon N: NONE  
Reaction upon A: NONE  
Acknowledge upon A: NONE

---

**F32897 (N, A) DRIVE-CLiQ: No communication to component**

**Reaction:** A\_INFEED: NONE (OFF1, OFF2)  
SERVO: OFF1 (DCBRAKE, NONE, OFF2, OFF3, STOP1, STOP2)  
VECTOR: OFF1 (DCBRAKE, NONE, OFF2, OFF3, STOP1, STOP2)

**Acknowledge:** IMMEDIATELY (POWER ON)

**Cause:** Communications with the DRIVE-CLiQ component specified by the fault value is not possible.  
One cause can be, e.g. that a DRIVE-CLiQ cable has been withdrawn.  
Fault value (r0949, decimal):  
Component ID.

**Remedy:** - check the DRIVE-CLiQ connections.  
- carry-out a POWER ON.

Reaction upon N: NONE  
Acknowledge upon N: NONE  
Reaction upon A: NONE  
Acknowledge upon A: NONE

---

**F32899 (N, A) Encoder 2: Unknown fault**

**Reaction:** A\_INFEED: OFF2 (NONE, OFF1)  
SERVO: OFF1 (DCBRAKE, NONE, OFF2, OFF3, STOP1, STOP2)  
VECTOR: OFF1 (DCBRAKE, NONE, OFF2, OFF3, STOP1, STOP2)

**Acknowledge:** IMMEDIATELY (POWER ON)

**Cause:** A fault occurred on the Sensor Module for encoder 2 that cannot be interpreted by the Control Unit firmware.  
This can occur if the firmware on the Sensor Module for encoder 2 is more recent than the firmware on the Control Unit.  
Fault value (r0949, decimal):  
Fault number.  
If required, the significance of this new fault can be read about in a more recent description of the Control Unit.

**Remedy:** - replace the firmware on the Sensor Module by an older firmware version (r0148).  
- upgrade the firmware on the Control Unit (r0018).

Reaction upon N: NONE  
Acknowledge upon N: NONE  
Reaction upon A: NONE  
Acknowledge upon A: NONE

---

**F32905 (N, A) Encoder 2: Parameterization error**

**Reaction:** A\_INFEED: OFF2 (NONE, OFF1)  
 SERVO: OFF1 (DCBRAKE, NONE, OFF2, OFF3, STOP1, STOP2)  
 VECTOR: OFF1 (DCBRAKE, NONE, OFF2, OFF3, STOP1, STOP2)

**Acknowledge:** IMMEDIATELY

**Cause:** A parameter of encoder 2 was detected as being incorrect.  
 It is possible that the parameterized encoder type does not match the connected encoder.  
 The parameter involved can be determined as follows:  
 - determine the parameter number using the fault value (r0949).  
 - determine the parameter index (p0188).  
 Fault value (r0949, decimal):  
 Parameter number.

**Remedy:** - check whether the connected encoder type matches the encoder that has been parameterized.  
 - correct the parameter specified by the fault value (r0949) and p0188.

Reaction upon N: NONE  
 Acknowledge upon N: NONE  
 Reaction upon A: NONE  
 Acknowledge upon A: NONE

---

**A32920 (F, N) Encoder 2: Temperature sensor fault**

**Reaction:** NONE

**Acknowledge:** NONE

**Cause:** When evaluating the temperature sensor, an error occurred. Alarm value (r2124, decimal):  
 1: Wire breakage or sensor not connected (KTY: R > 1630 Ohm).  
 2: Measured resistance too low (PTC: R < 20 Ohm, KTY: R < 50 Ohm).

**Remedy:** - check that the encoder cable is the correct type and is correctly connected.  
 - check the temperature sensor selection in p0600 to p0603.  
 - replace the Sensor Module (hardware defect or incorrect calibration data).

Reaction upon F: A\_INFEED: NONE (OFF1, OFF2)  
 SERVO: NONE (DCBRAKE, OFF1, OFF2, OFF3, STOP1, STOP2)  
 VECTOR: NONE (DCBRAKE, OFF1, OFF2, OFF3, STOP1, STOP2)

Acknowledge upon F: IMMEDIATELY

Reaction upon N: NONE  
 Acknowledge upon N: NONE

---

**A32999 (F, N) Encoder 2: Unknown alarm**

**Reaction:** NONE

**Acknowledge:** NONE

**Cause:** A alarm has occurred on the Sensor Module for encoder 2 that cannot be interpreted by the Control Unit firmware.  
 This can occur if the firmware on the Sensor Module for encoder 2 is more recent than the firmware on the Control Unit.  
 Alarm value (r2124, decimal):  
 Alarm number.  
 If required, the significance of this new alarm can be read about in a more recent description of the Control Unit.

**Remedy:** - replace the firmware on the Sensor Module by an older firmware version (r0148).  
 - upgrade the firmware on the Control Unit (r0018).

Reaction upon F: A\_INFEED: NONE (OFF1, OFF2)  
 SERVO: NONE (DCBRAKE, OFF1, OFF2, OFF3, STOP1, STOP2)  
 VECTOR: NONE (DCBRAKE, OFF1, OFF2, OFF3, STOP1, STOP2)

Acknowledge upon F: IMMEDIATELY (POWER ON)

Reaction upon N: NONE  
 Acknowledge upon N: NONE

**F33100 (N, A) Encoder 3: Zero mark clearance error**

**Reaction:** A\_INFEED: NONE (OFF1, OFF2)  
 SERVO: OFF1 (DCBRAKE, NONE, OFF2, OFF3, STOP1, STOP2)  
 VECTOR: OFF1 (DCBRAKE, NONE, OFF2, OFF3, STOP1, STOP2)

**Acknowledge:** PULSE INHIBIT

**Cause:** The measured zero mark distance does not correspond to the parameterized zero mark distance.  
 For distance-coded encoders, the zero mark distance is determined from zero marks detected pairs. This means that if a zero mark is missing, depending on the pair generation, this cannot result in a fault and also has no effect in the system.  
 The zero mark distance for the zero mark monitoring is set in p0425 (rotary encoder) or p0424 (linear encoder).  
 Fault value (r0949, decimal):  
 Last measured zero mark distance in increments (4 increments = 1 encoder pulse).  
 The sign designates the direction of motion when detecting the zero mark distance.

**Remedy:**

- check that the encoder cables are routed in compliance with EMC.
- check the plug connections.
- . check the encoder type (encoder with equidistant zero marks).
- adapt the parameter for the distance between zero marks (p0424, p0425).
- replace the encoder or encoder cable.

Reaction upon N: NONE  
 Acknowledge upon N: NONE  
 Reaction upon A: NONE  
 Acknowledge upon A: NONE

**F33101 (N, A) Encoder 3: Zero marked failed**

**Reaction:** A\_INFEED: NONE (OFF1, OFF2)  
 SERVO: OFF1 (DCBRAKE, NONE, OFF2, OFF3, STOP1, STOP2)  
 VECTOR: OFF1 (DCBRAKE, NONE, OFF2, OFF3, STOP1, STOP2)

**Acknowledge:** PULSE INHIBIT

**Cause:** The 1.5 x parameterized zero mark distance was exceeded.  
 The zero mark distance for the zero mark monitoring is set in p0425 (rotary encoder) or p0424 (linear encoder).  
 Fault value (r0949, decimal):  
 Number of increments after POWER ON or since the last zero mark that was detected (4 increments = 1 encoder pulse).

**Remedy:**

- check that the encoder cables are routed in compliance with EMC.
- check the plug connections.
- . check the encoder type (encoder with equidistant zero marks).
- adapt the parameter for the clearance between zero marks (p0425).
- replace the encoder or encoder cable.

Reaction upon N: NONE  
 Acknowledge upon N: NONE  
 Reaction upon A: NONE  
 Acknowledge upon A: NONE

**F33110 (N, A) Encoder 3: Serial communications error**

**Reaction:** A\_INFEED: NONE  
 SERVO: OFF1 (DCBRAKE, NONE, OFF2, OFF3)  
 VECTOR: OFF1 (DCBRAKE, NONE, OFF2, OFF3)

**Acknowledge:** PULSE INHIBIT

**Cause:** Serial communication protocol transfer error between the encoder and evaluation module.  
 Fault value (r0949, interpret binary):  
 Bit 0: Alarm bit in the position protocol.  
 Bit 1: Incorrect quiescent level on the data line.  
 Bit 2: Encoder does not respond (does not supply a start bit within 50 ms).  
 Bit 3: CRC error: The checksum in the protocol from the encoder does not match the data.  
 Bit 4: Encoder acknowledgement error: The encoder incorrectly understood the task (request) or cannot execute it.  
 Bit 5: Internal error in the serial driver: An illegal mode command was requested.  
 Bit 6: Timeout with cyclically reading.  
 Bit 8: Protocol is too long (e.g. > 64 bits).  
 Bit 9: Receive buffer overflow  
 Bit 10: Frame error when reading twice.  
 Bit 11: Parity error.  
 Bit 12: Data line signal level error during the monoflop time.

**Remedy:** Re fault value:  
 Bit 0 = 1: Encoder defective. F31111 may provide additional details.  
 Bit 1 = 1: Incorrect encoder type / replace the encoder or encoder cable.  
 Bit 2 = 1: Incorrect encoder type / replace the encoder or encoder cable.  
 Bit 3 = 1: EMC / connect the cable shield, replace the encoder or encoder cable.  
 Bit 4 = 1: EMC / connect the cable shield, replace the encoder or encoder cable, replace the Sensor Module.  
 Bit 5 = 1: EMC / connect the cable shield, replace the encoder or encoder cable, replace the Sensor Module.  
 Bit 6 = 1: Update the Sensor Module firmware.  
 Bit 8 = 1: Check the parameterization (p0429.2).  
 Bit 9 = 1: EMC / connect the cable shield, replace the encoder or encoder cable, replace the Sensor Module.  
 Bit 10 = 1: Check the parameterization (p0429.2, p0449).  
 Bit 11 = 1: Check the parameterization (p0436).  
 Bit 12 = 1: Check the parameterization (p0429.6).

Reaction upon N: NONE  
 Acknowledge upon N: NONE  
 Reaction upon A: NONE  
 Acknowledge upon A: NONE

**F33111 (N, A) Encoder 3: Absolute encoder EnDat, internal fault/error**

**Reaction:** A\_INFEED: NONE  
 SERVO: OFF1 (DCBRAKE, NONE, OFF2, OFF3)  
 VECTOR: OFF1 (DCBRAKE, NONE, OFF2, OFF3)

**Acknowledge:** PULSE INHIBIT

**Cause:** The EnDat encoder fault word contains fault bits that have been set.  
 Fault value (r0949, interpret binary):  
 Bit 0: Lighting system failed.  
 Bit 1: Signal amplitude too low.  
 Bit 2: Position value incorrect.  
 Bit 3: Encoder power supply overvoltage condition.  
 Bit 4: Encoder power supply undervoltage condition.  
 Bit 5: Encoder power supply overcurrent condition.  
 Bit 6: The battery must be changed.

**Remedy:**

Re fault value, bit 0 = 1:  
Encoder is defective. Replace the encoder, where the motor encoder has a direct DRIVE-CLiQ socket: Replace the motor.

Re fault value, bit 1 = 1:  
Encoder is defective. Replace the encoder, where the motor encoder has a direct DRIVE-CLiQ socket: Replace the motor.

Re fault value, bit 2 = 1:  
Encoder is defective. Replace the encoder, where the motor encoder has a direct DRIVE-CLiQ socket: Replace the motor.

Re fault value, bit 3 = 1:  
5 V power supply voltage fault.  
When using an SMC: Check the plug-in cable between the encoder and SMC or replace the SMC.  
When a motor encoder with a direct DRIVE-CLiQ connection is used: Replace the motor.

Re fault value, bit 4 = 1:  
5 V power supply voltage fault.  
When using an SMC: Check the plug-in cable between the encoder and SMC or replace the SMC.  
When using a motor with DRIVE-CLiQ: Replace the motor.

Re fault value, bit 5 = 1:  
Encoder is defective. Replace the encoder, where the motor encoder has a direct DRIVE-CLiQ socket: Replace the motor.

Re fault value, bit 6 = 1:  
The battery must be changed - only for encoders with battery back-up.

Reaction upon N: NONE  
Acknowledge upon N: NONE  
Reaction upon A: NONE  
Acknowledge upon A: NONE

---

**F33112 (N, A) Encoder 3: The error bit is set in the serial protocol**

**Reaction:** A\_INFEED: NONE  
SERVO: OFF1 (DCBRAKE, NONE, OFF2, OFF3)  
VECTOR: OFF1 (DCBRAKE, NONE, OFF2, OFF3)

**Acknowledge:** PULSE INHIBIT

**Cause:** Serial communication protocol transfer error between the encoder and evaluation module SMCxx.  
Fault value (r0949, decimal):

**Remedy:** Re fault value:

Reaction upon N: NONE  
Acknowledge upon N: NONE  
Reaction upon A: NONE  
Acknowledge upon A: NONE

**F33115 (N, A) Encoder 3: Amplitude error track A or B (A<sup>2</sup> + B<sup>2</sup>)**

**Reaction:** A\_INFEED: NONE  
 SERVO: OFF1 (DCBRAKE, NONE, OFF2, OFF3)  
 VECTOR: OFF1 (DCBRAKE, NONE, OFF2, OFF3)

**Acknowledge:** PULSE INHIBIT

**Cause:** The amplitude (A<sup>2</sup> + B<sup>2</sup>) does not lie within the tolerance bandwidth (software monitoring function).  
 SMC20:  
 The nominal signal level of the encoder must lie in the range 375 mV to 600 mV (500 mV -25 % / +20 %).  
 On the other hand, the response threshold is < 230 mV (frequency characteristic).  
 SMC10:  
 The nominal signal level is at 2900 mV (2.0 Vrms). The response threshold is < 1070 mV.  
 Fault value (r0949, decimal):  
 Low word:  
 Signal level, track A (16 bits with sign).  
 High word:  
 Signal level, track B (16 bits with sign).  
 SMC20:  
 A signal level of 500 mV peak value corresponds to the numerical value 5333 hex = 21299 dec.  
 SMC10:  
 A signal level of 2900 mV peak value corresponds to the numerical value 6666 hex = 26214 dec.

**Remedy:**

- check that the encoder cables are routed in compliance with EMC.
- check the plug connections.
- replace the encoder or encoder cable.
- check the encoder module (e.g. contacts).
- with measuring systems without their own bearing system: Adjust the scanning head and check the bearing system of the measuring wheel.
- for measuring systems with their own bearing system: Ensure that the encoder housing is not subject to any axial force.

Reaction upon N: NONE  
 Acknowledge upon N: NONE  
 Reaction upon A: NONE  
 Acknowledge upon A: NONE

**F33116 (N, A) Encoder 3: Amplitude error, monitoring track A + B**

**Reaction:** A\_INFEED: NONE  
 SERVO: OFF1 (DCBRAKE, NONE, OFF2, OFF3)  
 VECTOR: OFF1 (DCBRAKE, NONE, OFF2, OFF3)

**Acknowledge:** IMMEDIATELY

**Cause:** The amplitude of the rectified encoder signals A and B is not within the tolerance bandwidth (hardware monitoring).  
 The nominal signal level of the encoder must lie in the range 375 mV to 600 mV (500 mV -25 % / +20 %).  
 On the other hand, the hardware response thresholds are at < 176 mV and > 1.35 V.  
 Fault value (r0949, decimal):  
 Low word: Signal level, track A (16 bits with sign).  
 High word: Signal level, track B (16 bits with sign).  
 A signal level of 500 mV corresponds to the numerical value 5333 hex = 21299 dec.  
 These analog values are not measured at the same time with the hardware fault output.

**Remedy:**

- check that the encoder cables are routed in compliance with EMC.
- check the plug connections.
- replace the encoder or encoder cable.
- check the encoder module (e.g. contacts).

Reaction upon N: NONE  
 Acknowledge upon N: NONE  
 Reaction upon A: NONE  
 Acknowledge upon A: NONE

<b>F33117 (N, A)</b>	<b>Encoder 3: Inversion error, signals A and B and R</b>
<b>Reaction:</b>	A_INFEED: NONE SERVO: OFF1 (DCBRAKE, NONE, OFF2, OFF3), VECTOR: OFF1 (DCBRAKE, NONE, OFF2, OFF3)
<b>Acknowledge:</b>	IMMEDIATELY
<b>Cause:</b>	For a square-wave signal encoder (TTL. bipolar. double ended) the A* and B* and R* signals are not inverted with respect to signals A and B and R.
<b>Remedy:</b>	Check the setting of p0405: p0405.2 = 1 is only possible if the encoder is connected at X520. Check the encoder/cable: Does the encoder supply TTL signals and the associated inverted signals?
Reaction upon N:	NONE
Acknowledge upon N:	NONE
Reaction upon A:	NONE
Acknowledge upon A:	NONE
<b>F33118 (N, A)</b>	<b>Encoder 3: Speed difference outside the tolerance range</b>
<b>Reaction:</b>	A_INFEED: NONE SERVO: OFF1 (DCBRAKE, NONE, OFF2, OFF3) VECTOR: OFF1 (DCBRAKE, NONE, OFF2, OFF3)
<b>Acknowledge:</b>	PULSE INHIBIT
<b>Cause:</b>	For an HTL/TTL encoder, the speed difference has exceeded the value in p0492 over several sampling cycles. Fault value (r0949, decimal): Only for internal Siemens troubleshooting.
<b>Remedy:</b>	- check the tachometer feeder cable for interruptions. - check the grounding of the tachometer shielding. - if required, increase the maximum speed difference per sampling cycle (p0492).
Reaction upon N:	NONE
Acknowledge upon N:	NONE
Reaction upon A:	NONE
Acknowledge upon A:	NONE
<b>F33120 (N, A)</b>	<b>Encoder 3: Power supply voltage</b>
<b>Reaction:</b>	A_INFEED: NONE SERVO: OFF1 (DCBRAKE, NONE, OFF2, OFF3) VECTOR: OFF1 (DCBRAKE, NONE, OFF2, OFF3)
<b>Acknowledge:</b>	PULSE INHIBIT
<b>Cause:</b>	Encoder power supply voltage fault. Note: If the encoder cables 6FX2002-2EQ00-.... and 6FX2002-2CH00-.... are interchanged, this can result in the encoder being destroyed because the pins of the operating voltage are reversed. Fault value (r0949, interpret binary): Bit 0: Undervoltage condition on the sense line (threshold 4.75 V). Bit 1: Encoder power supply voltage overcurrent condition (threshold 450 mA).
<b>Remedy:</b>	For fault value, bit 0 = 1: - correct encoder cable connected? - check the plug connections of the encoder cable. - SMC30: Check the parameterization (p0404.22). For fault value, bit 1 = 1: - correct encoder cable connected? - replace the encoder or encoder cable.
Reaction upon N:	NONE
Acknowledge upon N:	NONE
Reaction upon A:	NONE
Acknowledge upon A:	NONE

---

**F33121 (N, A) Encoder 3: Coarse position error**

**Reaction:** A\_INFEED: NONE  
 SERVO: OFF1 (NONE, OFF2, OFF3)  
 VECTOR: OFF1 (NONE, OFF2, OFF3)

**Acknowledge:** PULSE INHIBIT

**Cause:** For the actual value sensing, an error was detected on the module. As a result of this error, it must be assumed that the actual value sensing supplies an incorrect coarse position.

**Remedy:** Replace the motor with DRIVE-CLiQ or the appropriate Sensor Module.

Reaction upon N: NONE  
 Acknowledge upon N: NONE  
 Reaction upon A: NONE  
 Acknowledge upon A: NONE

---

**F33125 (N, A) Encoder 1: Amplitude error track A or B overcontrolled**

**Reaction:** A\_INFEED: NONE  
 SERVO: ENCODER (DCBRAKE, NONE)  
 VECTOR: ENCODER (DCBRAKE, NONE)

**Acknowledge:** PULSE INHIBIT

**Cause:** The amplitude (track A or B) does not lie within the tolerance bandwidth (software monitoring function).  
 SMC20:  
 The nominal signal level of the encoder must lie in the range 375 mV to 600 mV (500 mV -25 % / +20 %).  
 On the other hand, the response threshold is > 760 mV (frequency characteristic).  
 SMC10:  
 The nominal signal level is at 2900 mV (2.0 Vrms). The response threshold is > 3582 mV.  
 Fault value (r0949, decimal):  
 Low word:  
 Signal level, track A (16 bits with sign).  
 High word:  
 Signal level, track B (16 bits with sign).  
 SMC20:  
 A signal level of 500 mV peak value corresponds to the numerical value 5333 hex = 21299 dec.  
 SMC10:  
 A signal level of 2900 mV peak value corresponds to the numerical value 6666 hex = 26214 dec.  
 See also: p0491 (Motor encoder fault response ENCODER)

**Remedy:**

- check that the encoder cables are routed in compliance with EMC.
- replace the encoder or encoder cable.
- with measuring systems without their own bearing system: Adjust the scanning head and check the bearing system of the measuring wheel.

Reaction upon N: NONE  
 Acknowledge upon N: NONE  
 Reaction upon A: NONE  
 Acknowledge upon A: NONE



---

<b>F33129 (N, A)</b>	<b>Encoder 3: Position difference, hall sensor/track C/D and A/B too large</b>
<b>Reaction:</b>	A_INFEED: NONE SERVO: OFF1 (DCBRAKE, NONE, OFF2, OFF3) VECTOR: OFF1 (DCBRAKE, NONE, OFF2, OFF3)
<b>Acknowledge:</b>	PULSE INHIBIT
<b>Cause:</b>	The error of track C/D is greater than +/-15 ° mechanical or +/-60 ° electrical. One period of track C/D corresponds to 360 ° mechanical. One period of the Hall signal corresponds to 360 ° electrical. The monitoring responds if, for example, Hall sensors are connected as equivalent for the C/D tracks with the incorrect rotational sense or supply values that are not accurate enough. After the fine synchronization using one reference mark or 2 reference marks for distance-coded encoders, this fault is no longer initiated, but instead, Alarm A33429. Fault value (r0949, decimal): Measured deviation as mechanical angle (16 bits with sign, 182 dec corresponds to 1 °).
<b>Remedy:</b>	- track C or D not connected. - correct the direction of rotation of the Hall sensor possibly connected as equivalent for track C/D. - check that the encoder cables are routed in compliance with EMC. - check the adjustment of the Hall sensor.
Reaction upon N:	NONE
Acknowledge upon N:	NONE
Reaction upon A:	NONE
Acknowledge upon A:	NONE

---

<b>F33130 (N, A)</b>	<b>Encoder 3: Zero mark and position error from the coarse synchronization</b>
<b>Reaction:</b>	A_INFEED: NONE SERVO: OFF1 (DCBRAKE, NONE, OFF2, OFF3, STOP1, STOP2) VECTOR: OFF1 (DCBRAKE, NONE, OFF2, OFF3, STOP1, STOP2)
<b>Acknowledge:</b>	PULSE INHIBIT
<b>Cause:</b>	After initializing the pole position using track C/D, Hall signals or pole position identification routine, the zero mark was detected outside the permissible range. For distance-coded encoders, the test is carried-out after passing 2 zero marks. Fine synchronization was not carried-out. The deviation may be up to 18 ° mechanical or up to 60 ° electrical. Fault value (r0949, decimal): Normalization: 32768 = 180 ° High word: Mechanical zero mark position determined. If the initialization via a track C/D is selected in p0404, then it is checked whether the zero mark occurs in an angular range of +/-18 ° mechanical. Low word: Deviation of the zero mark from the expected position as electrical angle. If the correction of the commutation position with the zero mark is selected in p0404, then a difference of a maximum of +/- 60 ° electrical is permitted.
<b>Remedy:</b>	- check that the encoder cables are routed in compliance with EMC. - check the plug connections. - if the Hall sensor is used as an equivalent for track C/D, check the connection. - check the connection of track C or D. - replace the encoder or encoder cable.
Reaction upon N:	NONE
Acknowledge upon N:	NONE
Reaction upon A:	NONE
Acknowledge upon A:	NONE

---

**F33131 (N, A) Encoder 3: Deviation, position incremental/absolute too large**

**Reaction:** A\_INFEED: NONE  
SERVO: OFF1 (DCBRAKE, NONE, OFF2, OFF3, STOP1, STOP2)  
VECTOR: OFF1 (DCBRAKE, NONE, OFF2, OFF3, STOP1, STOP2)

**Acknowledge:** PULSE INHIBIT

**Cause:** Absolute encoder: When cyclically reading the absolute position, an excessively high difference to the incremental position was detected. The absolute position that was read is rejected.  
Limit value for the deviation:  
- EnDat encoder: Is supplied from the encoder and is a minimum of 2 quadrants (e.g. EQI 1325 > 2 quadrants, EQN 1325 > 50 quadrants).  
- other encoders: 15 pulses = 60 quadrants.  
Fault value (r0949, decimal):  
Deviation in quadrants (1 pulse = 4 quadrants).  
Incremental encoder: When the zero pulse is passed, a deviation in the incremental position was detected.

**Remedy:** - check that the encoder cables are routed in compliance with EMC.  
- check the plug connections.  
- replace the encoder or encoder cable.  
- check whether the coding disk is dirty or there are strong ambient magnetic fields.

Reaction upon N: NONE  
Acknowledge upon N: NONE  
Reaction upon A: NONE  
Acknowledge upon A: NONE

---

**F33150 (N, A) Encoder 3: Initialization error**

**Reaction:** A\_INFEED: NONE  
SERVO: OFF1 (DCBRAKE, NONE, OFF2, OFF3, STOP1, STOP2)  
VECTOR: OFF1 (DCBRAKE, NONE, OFF2, OFF3, STOP1, STOP2)

**Acknowledge:** PULSE INHIBIT

**Cause:** Encoder functionality selected in p0404 is not operating correctly.  
Fault value (r0949, interpret hexadecimal):  
The fault value is a bit field. Every set bit indicates functionality that is faulted.  
The bit assignment corresponds to that of p0404 (e.g. bit 5 set: Error track C/D).

**Remedy:** - Check that p0404 is correctly set.  
- check the encoder type used (incremental/absolute value) and for SMCxx, the encoder cable.  
- if relevant, note additional fault/error messages that describe the fault in detail.

Reaction upon N: NONE  
Acknowledge upon N: NONE  
Reaction upon A: NONE  
Acknowledge upon A: NONE

---

**A33400 (F, N) Encoder 3: Alarm threshold, zero mark distance error**

**Reaction:** NONE

**Acknowledge:** NONE

**Cause:** The measured zero mark distance does not correspond to the parameterized zero mark distance.  
For distance-coded encoders, the zero mark distance is determined from zero marks detected pairs. This means that if a zero mark is missing, depending on the pair generation, this cannot result in a fault and also has no effect in the system.  
The zero mark distance for the zero mark monitoring is set in p0425 (rotary encoder) or p0424 (linear encoder).  
Alarm value (r2124, decimal):  
Last measured zero mark distance in increments (4 increments = 1 encoder pulse).  
The sign designates the direction of motion when detecting the zero mark distance.

**Remedy:**

- check that the encoder cables are routed in compliance with EMC.
- check the plug connections.
- . check the encoder type (encoder with equidistant zero marks).
- adapt the parameter for the distance between zero marks (p0424, p0425).
- replace the encoder or encoder cable.

Reaction upon F: A\_INFEED: NONE (OFF1, OFF2)  
 SERVO: NONE (DCBRAKE, OFF1, OFF2, OFF3, STOP1, STOP2)  
 VECTOR: NONE (DCBRAKE, OFF1, OFF2, OFF3, STOP1, STOP2)

Acknowledge upon F: IMMEDIATELY

Reaction upon N: NONE

Acknowledge upon N: NONE

**A33401 (F, N) Encoder 3: Alarm threshold, zero marked failed**

**Reaction:** NONE

**Acknowledge:** NONE

**Cause:** The 1.5 x parameterized zero mark distance was exceeded.  
 The zero mark distance for the zero mark monitoring is set in p0425 (rotary encoder) or p0424 (linear encoder).  
 Alarm value (r2124, decimal):  
 Number of increments after POWER ON or since the last zero mark that was detected (4 increments = 1 encoder pulse).

**Remedy:**

- check that the encoder cables are routed in compliance with EMC.
- check the plug connections.
- . check the encoder type (encoder with equidistant zero marks).
- adapt the parameter for the clearance between zero marks (p0425).
- replace the encoder or encoder cable.

Reaction upon F: A\_INFEED: NONE (OFF1, OFF2)  
 SERVO: NONE (DCBRAKE, OFF1, OFF2, OFF3, STOP1, STOP2)  
 VECTOR: NONE (DCBRAKE, OFF1, OFF2, OFF3, STOP1, STOP2)

Acknowledge upon F: IMMEDIATELY

Reaction upon N: NONE

Acknowledge upon N: NONE

**F33405 (N, A) Encoder 3: Encoder evaluation temperature too high**

**Reaction:** A\_INFEED: NONE (OFF1, OFF2)  
 SERVO: NONE (DCBRAKE, OFF1, OFF2, OFF3, STOP1, STOP2)  
 VECTOR: NONE (DCBRAKE, OFF1, OFF2, OFF3, STOP1, STOP2)

**Acknowledge:** IMMEDIATELY (POWER ON)

**Cause:** The encoder evaluation for a motor with DRIVE-CLiQ has detected an excessively high temperature.  
 The fault threshold is 125 ° C.  
 Alarm value (r2124, decimal):  
 Measured board/module temperature in 0.1 °C.

**Remedy:** Reduce the ambient temperature for the DRIVE-CLiQ connection of the motor.

Reaction upon N: NONE

Acknowledge upon N: NONE

Reaction upon A: NONE

Acknowledge upon A: NONE

<b>A33410 (F, N)</b>	<b>Encoder 3: Serial communications</b>
<b>Reaction:</b>	NONE
<b>Acknowledge:</b>	NONE
<b>Cause:</b>	Serial communication protocol transfer error between the encoder and evaluation module. Alarm value (r2124, interpret binary): Bit 0: Alarm bit in the position protocol. Bit 1: Incorrect quiescent level on the data line. Bit 2: Encoder does not respond (does not supply a start bit within 50 ms). Bit 3: CRC error: The checksum in the protocol from the encoder does not match the data. Bit 4: Encoder acknowledgement error: The encoder incorrectly understood the task (request) or cannot execute it. Bit 5: Internal error in the serial driver: An illegal mode command was requested. Bit 6: Timeout with cyclically reading. Bit 8: Protocol is too long (e.g. > 64 bits). Bit 9: Receive buffer overflow. Bit 10: Frame error when reading twice. Bit 11: Parity error. Bit 12: Data line signal level error during the monoflop time.
<b>Remedy:</b>	- check that the encoder cables are routed in compliance with EMC. - check the plug connections. - replace the encoder.
Reaction upon F:	A_INFEED: NONE (OFF1, OFF2) SERVO: NONE (DCBRAKE, OFF1, OFF2, OFF3, STOP1, STOP2) VECTOR: NONE (DCBRAKE, OFF1, OFF2, OFF3, STOP1, STOP2)
Acknowledge upon F:	IMMEDIATELY
Reaction upon N:	NONE
Acknowledge upon N:	NONE

<b>A33411 (F, N)</b>	<b>Encoder 3: EnDat encoder signals alarms</b>
<b>Reaction:</b>	NONE
<b>Acknowledge:</b>	NONE
<b>Cause:</b>	The error word of the EnDat encoder has alarm bits that have been set. Alarm value (r2124, interpret binary): Bit 0: Frequency exceeded (speed too high). Bit 1: Temperature exceeded. Bit 2: Control reserve, lighting system exceeded. Bit 3: Battery discharged. Bit 4: Reference point passed.
<b>Remedy:</b>	Replace encoder.
Reaction upon F:	A_INFEED: NONE (OFF1, OFF2) SERVO: NONE (DCBRAKE, OFF1, OFF2, OFF3, STOP1, STOP2) VECTOR: NONE (DCBRAKE, OFF1, OFF2, OFF3, STOP1, STOP2)
Acknowledge upon F:	IMMEDIATELY
Reaction upon N:	NONE
Acknowledge upon N:	NONE

**A33414 (F, N) Encoder 3: Amplitude error track C or D (C<sup>2</sup> + D<sup>2</sup>)**

**Reaction:** NONE  
**Acknowledge:** NONE  
**Cause:** The amplitude (C<sup>2</sup> + D<sup>2</sup>) of track C or D of the encoder or from the Hall signals, is not within the tolerance bandwidth.  
 The nominal signal must be in the range 375 mV to 600 mV (500 mV -25 % / +20 %).  
 On the other hand, the response thresholds are < 230 mV and > 750 mV (frequency characteristic).  
 This fault also occurs if the A/D converter is overcontrolled.  
 If the amplitude is not within the tolerance bandwidth, then it cannot be used to initialize the start position.  
 Alarm value (r2124, decimal):  
 Low word: Signal level, track C (16 bits with sign).  
 High word: Signal level, track D (16 bits with sign).  
 A signal level of 500 mV corresponds to the numerical value 5333 hex = 21299 dec.

**Remedy:**

- check that the encoder cables are routed in compliance with EMC.
- check the plug connections.
- replace the encoder or encoder cable.
- check the encoder module (e.g. contacts).
- check the Hall sensor box

Reaction upon F: A\_INFEED: NONE (OFF1, OFF2)  
 SERVO: NONE (DCBRAKE, OFF1, OFF2, OFF3, STOP1, STOP2)  
 VECTOR: NONE (DCBRAKE, OFF1, OFF2, OFF3, STOP1, STOP2)

Acknowledge upon F: IMMEDIATELY

Reaction upon N: NONE  
 Acknowledge upon N: NONE

**N33415 (F, A) Encoder 3: Amplitude alarm track A or B (A<sup>2</sup> + B<sup>2</sup>)**

**Reaction:** NONE  
**Acknowledge:** NONE  
**Cause:** The amplitude (A<sup>2</sup> + B<sup>2</sup>) of track A or B is not within the tolerance bandwidth.  
 SMC20:  
 The nominal signal level is at 500 mV (500 mV -25 % / +20 %). The response threshold is < 300 mV.  
 SMC10:  
 The nominal signal level is at 2900 mV (2.0 Vrms). The response threshold is < 1414 mV (1.0 Vrms).  
 Alarm value (r2124, decimal):  
 Low word: Amplitude square root(A\*A + B\*B).  
 SMC20: A signal level of 500 mV peak value corresponds to the numerical value 299A hex = 10650 dec.  
 SMC10:  
 A signal level of 2900 mV peak value corresponds to the numerical value 3333 hex = 13107 dec.  
 High word:  
 Angle 0 to 65535 corresponds to 0 to 360 degrees of the fine position. Zero degrees is at the negative zero crossover of track B.

**Remedy:**

- check the speed range, frequency characteristic (amplitude characteristic) of the measuring equipment is not sufficient for the speed range.
- check that the encoder cables are routed in compliance with EMC.
- check the plug connections.
- replace the encoder or encoder cable.
- check the encoder module (e.g. contacts).
- dirty code disk
- aged lighting system.

Reaction upon F: A\_INFEED: NONE (OFF1, OFF2)  
 SERVO: NONE (DCBRAKE, OFF1, OFF2, OFF3, STOP1, STOP2)  
 VECTOR: NONE (DCBRAKE, OFF1, OFF2, OFF3, STOP1, STOP2)

Acknowledge upon F: IMMEDIATELY

Reaction upon A: NONE  
 Acknowledge upon A: NONE

<b>A33418 (F, N)</b>	<b>Encoder 3: Speed difference per sampling rate exceeded</b>
<b>Reaction:</b>	NONE
<b>Acknowledge:</b>	NONE
<b>Cause:</b>	For an HTL/TTL encoder, the speed difference between two sampling cycles has exceeded the value in p0492. Alarm value (r2124, decimal): Only for internal Siemens troubleshooting.
<b>Remedy:</b>	- check the tachometer feeder cable for interruptions. - check the grounding of the tachometer shielding. - if required, increase the setting of p0492.
Reaction upon F:	A_INFEED: NONE (OFF1, OFF2) SERVO: NONE (DCBRAKE, OFF1, OFF2, OFF3, STOP1, STOP2) VECTOR: NONE (DCBRAKE, OFF1, OFF2, OFF3, STOP1, STOP2)
Acknowledge upon F:	IMMEDIATELY
Reaction upon N:	NONE
Acknowledge upon N:	NONE
<b>A33419 (F, N)</b>	<b>Encoder 3: Track A or B outside the tolerance range</b>
<b>Reaction:</b>	NONE
<b>Acknowledge:</b>	NONE
<b>Cause:</b>	The amplitude, phase or offset correction for track A or B is at the limit. Amplitude error correction: Amplitude B / Amplitude A = 0.78 ... 1.27 Phase: <84 degrees or >96 degrees SMC20: Offset correction: +/-140 mV SMC10: Offset correction: +/-650 mV Alarm value (r2124, interpret hexadecimal): xxx1: Minimum of the offset correction, track B xxx2: Maximum of the offset correction, track B xx1x: Minimum of the offset correction, track A xx2x: Maximum of the offset correction, track A x1xx: Minimum of the amplitude correction, track B/A x2xx: Maximum of the amplitude correction, track B/A 1xxx: Minimum of the phase error correction 2xxx: Maximum of the phase error correction
<b>Remedy:</b>	- check mechanical mounting tolerances for encoders without their own bearings (e.g. toothed-wheel encoders). - check the plug connections (also the transition resistance). - check the encoder signals. - replace the encoder or encoder cable.
Reaction upon F:	A_INFEED: NONE (OFF1, OFF2) SERVO: NONE (DCBRAKE, OFF1, OFF2, OFF3, STOP1, STOP2) VECTOR: NONE (DCBRAKE, OFF1, OFF2, OFF3, STOP1, STOP2)
Acknowledge upon F:	IMMEDIATELY
Reaction upon N:	NONE
Acknowledge upon N:	NONE
<b>A33429 (F, N)</b>	<b>Encoder 3: Position difference, hall sensor/track C/D and A/B too large</b>
<b>Reaction:</b>	NONE
<b>Acknowledge:</b>	NONE
<b>Cause:</b>	The error of track C/D is greater than +/-15 ° mechanical or +/-60 ° electrical. One period of track C/D corresponds to 360 ° mechanical. One period of the Hall signal corresponds to 360 ° electrical. The monitoring responds if, for example, Hall sensors are connected as equivalent for the C/D tracks with the incorrect rotational sense or supply values that are not accurate enough. Alarm value (r2124, decimal): Measured deviation as mechanical angle (16 bits with sign, 182 dec corresponds to 1 °).

**Remedy:**

- track C or D not connected.
- correct the direction of rotation of the Hall sensor possibly connected as equivalent for track C/D.
- check that the encoder cables are routed in compliance with EMC.
- check the adjustment of the Hall sensor.

Reaction upon F: A\_INFEED: NONE (OFF1, OFF2)  
 SERVO: NONE (DCBRAKE, OFF1, OFF2, OFF3, STOP1, STOP2)  
 VECTOR: NONE (DCBRAKE, OFF1, OFF2, OFF3, STOP1, STOP2)

Acknowledge upon F: IMMEDIATELY

Reaction upon N: NONE

Acknowledge upon N: NONE

**A33431 (F, N) Encoder 3: Deviation, position incremental/absolute too large**

**Reaction:** NONE

**Acknowledge:** NONE

**Cause:** Absolute encoder: When cyclically reading the absolute position, an excessively high difference to the incremental position was detected.  
 Alarm value (r2124, decimal):  
 Deviation in quadrants (1 pulse = 4 quadrants).  
 Incremental encoder: When the zero pulse is passed, a deviation in the incremental position was detected.

**Remedy:**

- check that the encoder cables are routed in compliance with EMC.
- check the plug connections.
- replace the encoder or encoder cable.
- coding disk dirty or strong magnetic fields.

Reaction upon F: A\_INFEED: NONE (OFF1, OFF2)  
 SERVO: NONE (DCBRAKE, OFF1, OFF2, OFF3, STOP1, STOP2)  
 VECTOR: NONE (DCBRAKE, OFF1, OFF2, OFF3, STOP1, STOP2)

Acknowledge upon F: IMMEDIATELY

Reaction upon N: NONE

Acknowledge upon N: NONE

**F33501 (N, A) Encoder 3: Position tracking encoder position outside tolerance window**

**Reaction:** A\_INFEED: NONE  
 SERVO: OFF1 (NONE, OFF2, OFF3)  
 VECTOR: OFF1 (NONE, OFF2, OFF3)

**Acknowledge:** IMMEDIATELY

**Cause:** When powered-down, the drive/encoder was moved through a distance greater than what was set in the tolerance window.  
 See also: p0413 (Measuring gearbox, position tracking tolerance window)

**Remedy:** Re-adjust the drive.

Reaction upon N: NONE

Acknowledge upon N: NONE

Reaction upon A: NONE

Acknowledge upon A: NONE

---

**F33502 (N, A) Encoder 3: Encoder with measuring gear, without valid signals**

**Reaction:** A\_INFEED: OFF1 (OFF2)  
SERVO: OFF1 (OFF2, OFF3)  
VECTOR: OFF1 (OFF2, OFF3)

**Acknowledge:** IMMEDIATELY

**Cause:** The encoder with measuring gear no longer provides any valid signals.

**Remedy:** It must be ensured that all of the encoders, with mounted measuring gear, provide valid actual values in operation.

Reaction upon N: NONE  
Acknowledge upon N: NONE  
Reaction upon A: NONE  
Acknowledge upon A: NONE

---

**F33801 (N, A) Encoder 3 DRIVE-CLiQ: Sign-of-life missing**

**Reaction:** A\_INFEED: OFF2 (NONE)  
SERVO: OFF1 (DCBRAKE, NONE, OFF2, OFF3)  
VECTOR: OFF1 (DCBRAKE, NONE, OFF2, OFF3)

**Acknowledge:** IMMEDIATELY

**Cause:** DRIVE-CLiQ communications error between the Control Unit and the encoder involved.  
Fault value (r0949, interpret hexadecimal):  
0A: The sign-of-life bit in the receive telegram is not set.

**Remedy:** - check the electrical cabinet design and cable routing for EMC compliance.  
- replace the component involved.  
See also: p9916 (DRIVE-CLiQ data transfer error, shutdown threshold, slave)

Reaction upon N: NONE  
Acknowledge upon N: NONE  
Reaction upon A: NONE  
Acknowledge upon A: NONE

---

**F33802 (N, A) Encoder 3: Time slice overflow**

**Reaction:** A\_INFEED: OFF2 (NONE)  
SERVO: OFF1 (DCBRAKE, NONE, OFF2, OFF3)  
VECTOR: OFF1 (DCBRAKE, NONE, OFF2, OFF3)

**Acknowledge:** IMMEDIATELY

**Cause:** Time slice overflow, encoder 3.  
Fault value (r0949, decimal):  
9: Time slice overflow of the fast (current controller clock cycle) time slice.  
10: Time slice overflow of the average time slice.  
12: Time slice overflow of the slow time slice.  
999: Timeout when waiting for SYNO, e.g. unexpected return to non-cyclic operation.

**Remedy:** Reduce the current controller frequency.

Reaction upon N: NONE  
Acknowledge upon N: NONE  
Reaction upon A: NONE  
Acknowledge upon A: NONE

---



---

**F33804 (N, A) Encoder 3: CRC CODE RAM**

**Reaction:** A\_INFEED: OFF2 (NONE)  
SERVO: OFF1 (DCBRAKE, NONE, OFF2, OFF3)  
VECTOR: OFF1 (DCBRAKE, NONE, OFF2, OFF3)

**Acknowledge:** IMMEDIATELY

**Cause:** The checksum via the CODE-RAM of the Sensor Module has changed in operation.  
Fault value (r0949, interpret hexadecimal):  
Difference between the checksum at POWER ON and the actual checksum.

**Remedy:** Hardware defect: Replace the Sensor Module.  
Firmware error: If required, upgrade the firmware.

Reaction upon N: NONE  
Acknowledge upon N: NONE  
Reaction upon A: NONE  
Acknowledge upon A: NONE

---

**F33805 (N, A) Encoder 3: EPROM checksum error**

**Reaction:** A\_INFEED: OFF2 (NONE)  
SERVO: OFF1 (DCBRAKE, NONE, OFF2, OFF3)  
VECTOR: OFF1 (DCBRAKE, NONE, OFF2, OFF3)

**Acknowledge:** IMMEDIATELY

**Cause:** Internal parameter data is corrupted.  
Fault value (r0949, interpret hexadecimal):  
01: EEPROM access error.  
02: Too many blocks in the EEPROM.

**Remedy:** Replace the module.

Reaction upon N: NONE  
Acknowledge upon N: NONE  
Reaction upon A: NONE  
Acknowledge upon A: NONE

---

**F33806 (N, A) Encoder 3: Initialization error**

**Reaction:** A\_INFEED: OFF2 (NONE)  
SERVO: OFF1 (DCBRAKE, NONE, OFF2, OFF3)  
VECTOR: OFF1 (DCBRAKE, NONE, OFF2, OFF3)

**Acknowledge:** PULSE INHIBIT

**Cause:** The encoder was not successfully initialized.  
Fault value (r0949, interpret hexadecimal):  
1, 2, 3: Encoder initialization with the motor rotating.

**Remedy:** Acknowledge the fault.

Reaction upon N: NONE  
Acknowledge upon N: NONE  
Reaction upon A: NONE  
Acknowledge upon A: NONE

---

**F33812 (N, A) Encoder 3: A cycle requested from the CU or RX/TX timing is not supported**

**Reaction:** OFF2  
**Acknowledge:** IMMEDIATELY  
**Cause:** A cycle requested from the CU or RX/TX timing is not supported  
 Fault value (r0949):  
 0: Application cycle is not supported.  
 1: DQ cycle is not supported.  
 2: Clearance between RX and TX instants in time too low.  
 3: TX instant in time too early.

**Remedy:**  
 Reaction upon N: NONE  
 Acknowledge upon N: NONE  
 Reaction upon A: NONE  
 Acknowledge upon A: NONE

---

**F33820 (N, A) Encoder 3 DRIVE-CLiQ: Telegram error**

**Reaction:** A\_INFEED: OFF2  
 SERVO: OFF1 (DCBRAKE, NONE, OFF2, OFF3)  
 VECTOR: OFF1 (DCBRAKE, NONE, OFF2, OFF3)  
**Acknowledge:** IMMEDIATELY  
**Cause:** DRIVE-CLiQ communications error between the Control Unit and the encoder involved.  
 Fault value (r0949, interpret hexadecimal):  
 01: CRC error.  
 02: Telegram is shorter than specified in the length byte or in the receive list.  
 03: Telegram is longer than specified in the length byte or in the receive list.  
 04: The length of the receive telegram does not match the receive list.  
 05: The type of the receive telegram does not match the receive list.  
 06: The address of the encoder in the telegram and in the receive list do not match.  
 07: The encoder expects a SYNC telegram, but the receive telegram is not a SYNC telegram.  
 08: The encoder does not expect a SYNC telegram, but the receive telegram is a SYNC telegram.  
 09: The error bit in the receive telegram is set.  
 10: The receive telegram is too early.

**Remedy:**  
 - carry-out a POWER ON.  
 - check the electrical cabinet design and cable routing for EMC compliance.  
 - check the DRIVE-CLiQ wiring (interrupted cable, contacts, ...).  
 See also: p9916 (DRIVE-CLiQ data transfer error, shutdown threshold, slave)

Reaction upon N: NONE  
 Acknowledge upon N: NONE  
 Reaction upon A: NONE  
 Acknowledge upon A: NONE

---

**F33835 (N, A) Encoder 3 DRIVE-CLiQ: Cyclic data transfer error**

**Reaction:** A\_INFEED: OFF2  
 SERVO: OFF1 (DCBRAKE, NONE, OFF2, OFF3)  
 VECTOR: OFF1 (DCBRAKE, NONE, OFF2, OFF3)  
**Acknowledge:** IMMEDIATELY  
**Cause:** DRIVE-CLiQ communications error between the Control Unit and the encoder involved. The nodes do not send and receive in synchronism.  
 Fault value (r0949, interpret hexadecimal):  
 21: The cyclic telegram has not been received.  
 22: Timeout in the telegram receive list.  
 40: Timeout in the telegram send list.

**Remedy:**  
 - carry-out a POWER ON.  
 - replace the component involved.  
 See also: p9916 (DRIVE-CLiQ data transfer error, shutdown threshold, slave)

Reaction upon N: NONE  
 Acknowledge upon N: NONE  
 Reaction upon A: NONE  
 Acknowledge upon A: NONE

**F33836 (N, A) Encoder 3 DRIVE-CLiQ: Send error for DRIVE-CLiQ data**

**Reaction:** A\_INFEED: OFF2  
 SERVO: OFF1 (DCBRAKE, NONE, OFF2, OFF3)  
 VECTOR: OFF1 (DCBRAKE, NONE, OFF2, OFF3)

**Acknowledge:** IMMEDIATELY

**Cause:** DRIVE-CLiQ communications error between the Control Unit and the encoder involved. Data were not able to be sent.  
 Fault value (r0949, interpret hexadecimal):  
 41: Telegram type does not match send list.

**Remedy:** Carry-out a POWER ON.

Reaction upon N: NONE  
 Acknowledge upon N: NONE  
 Reaction upon A: NONE  
 Acknowledge upon A: NONE

**F33837 (N, A) Encoder 3 DRIVE-CLiQ: Component fault**

**Reaction:** A\_INFEED: OFF2  
 SERVO: OFF1 (DCBRAKE, NONE, OFF2, OFF3)  
 VECTOR: OFF1 (DCBRAKE, NONE, OFF2, OFF3)

**Acknowledge:** IMMEDIATELY

**Cause:** Fault detected on the DRIVE-CLiQ component involved. Faulty hardware cannot be excluded.  
 Fault value (r0949, interpret hexadecimal):  
 20: Error in the telegram header.  
 23: Receive error: The telegram buffer memory contains an error.  
 42: Send error: The telegram buffer memory contains an error.  
 43: Send error: The telegram buffer memory contains an error.

**Remedy:**

- check the DRIVE-CLiQ wiring (interrupted cable, contacts, ...).
- check the electrical cabinet design and cable routing for EMC compliance.
- if required, use another DRIVE-CLiQ socket (p9904).
- replace the component involved.

Reaction upon N: NONE  
 Acknowledge upon N: NONE  
 Reaction upon A: NONE  
 Acknowledge upon A: NONE

---

**F33845 (N, A) Encoder 3 DRIVE-CLiQ: Cyclic data transfer error**

**Reaction:** A\_INFEED: OFF2  
 SERVO: OFF1 (DCBRAKE, NONE, OFF2, OFF3)  
 VECTOR: OFF1 (DCBRAKE, NONE, OFF2, OFF3)

**Acknowledge:** IMMEDIATELY

**Cause:** DRIVE-CLiQ communications error between the Control Unit and the encoder involved.  
 Fault value (r0949, interpret hexadecimal):  
 0B: Synchronization error during alternating cyclic data transfer.

**Remedy:** Carry-out a POWER ON.  
 See also: p9916 (DRIVE-CLiQ data transfer error, shutdown threshold, slave)

Reaction upon N: NONE  
 Acknowledge upon N: NONE  
 Reaction upon A: NONE  
 Acknowledge upon A: NONE

---

**F33850 (N, A) Encoder 3: Sensor Module, internal software error**

**Reaction:** A\_INFEED: OFF2 (NONE)  
 SERVO: OFF1 (DCBRAKE, NONE, OFF2, OFF3)  
 VECTOR: OFF1 (DCBRAKE, NONE, OFF2, OFF3)

**Acknowledge:** POWER ON

**Cause:** Internal software error in the Sensor Module of encoder 3.  
 Fault value (r0949, decimal):  
 1: Background time slice is blocked.  
 2: Checksum over the code memory is not OK.  
 10000: OEM memory of the EnDat encoder contains data that cannot be interpreted.

**Remedy:** - replace the Sensor Module.  
 - if required, upgrade the firmware in the Sensor Module.  
 - contact the Hotline.

Reaction upon N: NONE  
 Acknowledge upon N: NONE  
 Reaction upon A: NONE  
 Acknowledge upon A: NONE

---

**F33851 (N, A) CU DRIVE-CLiQ: Sign-of-life missing**

**Reaction:** A\_INFEED: NONE (OFF1, OFF2)  
 SERVO: OFF1 (DCBRAKE, NONE, OFF2, OFF3)  
 VECTOR: OFF1 (DCBRAKE, NONE, OFF2, OFF3)

**Acknowledge:** IMMEDIATELY

**Cause:** A DRIVE-CLiQ communications error has occurred between the Control Unit and the Sensor Module (encoder 3) involved. The DRIVE-CLiQ component did not set the sign of life to the Control Unit.  
 Fault value (r0949, interpret hexadecimal):  
 0A: The sign-of-life bit in the receive telegram is not set.

**Remedy:** Upgrade the firmware of the component involved.

Reaction upon N: NONE  
 Acknowledge upon N: NONE  
 Reaction upon A: NONE  
 Acknowledge upon A: NONE

---

**F33860 (N, A) CU DRIVE-CLiQ: Telegram error**

**Reaction:** A\_INFEED: NONE (OFF1, OFF2)  
SERVO: OFF1 (DCBRAKE, NONE, OFF2, OFF3)  
VECTOR: OFF1 (DCBRAKE, NONE, OFF2, OFF3)

**Acknowledge:** IMMEDIATELY

**Cause:** DRIVE-CLiQ communications error between the Control Unit and the encoder involved.  
Fault value (r0949, interpret hexadecimal):  
11: CRC error and the receive telegram is too early.  
01: CRC error.  
12: The telegram is shorter than that specified in the length byte or in the receive list and the receive telegram is too early.  
02: Telegram is shorter than specified in the length byte or in the receive list.  
13: The telegram is longer than that specified in the length byte or in the receive list and the receive telegram is too early.  
03: Telegram is longer than specified in the length byte or in the receive list.  
14: The length of the receive telegram does not match the receive list and the receive telegram is too early.  
04: The length of the receive telegram does not match the receive list.  
15: The type of the receive telegram does not match the receive list and the receive telegram is too early.  
05: The type of the receive telegram does not match the receive list.  
16: The address of the encoder in the telegram and in the receive list does not match and the receive telegram is too early.  
06: The address of the encoder in the telegram and in the receive list do not match.  
19: The error bit in the receive telegram is set and the receive telegram is too early.  
09: The error bit in the receive telegram is set.  
10: The receive telegram is too early.

**Remedy:** - carry-out a POWER ON.  
- check the electrical cabinet design and cable routing for EMC compliance.  
- check the DRIVE-CLiQ wiring (interrupted cable, contacts, ...).  
See also: p9915 (DRIVE-CLiQ data transfer error, shutdown threshold, master)

Reaction upon N: NONE  
Acknowledge upon N: NONE  
Reaction upon A: NONE  
Acknowledge upon A: NONE

---

**F33885 (N, A) CU DRIVE-CLiQ: Cyclic data transfer error**

**Reaction:** A\_INFEED: NONE (OFF1, OFF2)  
SERVO: OFF1 (DCBRAKE, NONE, OFF2, OFF3)  
VECTOR: OFF1 (DCBRAKE, NONE, OFF2, OFF3)

**Acknowledge:** IMMEDIATELY

**Cause:** DRIVE-CLiQ communications error between the Control Unit and the encoder involved. The nodes do not send and receive in synchronism.  
Fault value (r0949, interpret hexadecimal):  
1A: Sign-of-life bit in the receive telegram not set and the receive telegram is too early.  
21: The cyclic telegram has not been received.  
22: Timeout in the telegram receive list.  
40: Timeout in the telegram send list.  
62: Error at the transition to cyclic operation.

**Remedy:** - check the power supply voltage of the component involved.  
- carry-out a POWER ON.  
- replace the component involved.  
See also: p9915 (DRIVE-CLiQ data transfer error, shutdown threshold, master)

Reaction upon N: NONE  
Acknowledge upon N: NONE  
Reaction upon A: NONE  
Acknowledge upon A: NONE

---

**F33886 (N, A) CU DRIVE-CLiQ: Error when sending DRIVE-CLiQ data**

**Reaction:** A\_INFEED: NONE (OFF1, OFF2)  
 SERVO: OFF1 (DCBRAKE, NONE, OFF2, OFF3)  
 VECTOR: OFF1 (DCBRAKE, NONE, OFF2, OFF3)

**Acknowledge:** IMMEDIATELY

**Cause:** DRIVE-CLiQ communications error between the Control Unit and the encoder involved. Data were not able to be sent.  
 Fault value (r0949, interpret hexadecimal):  
 41: Telegram type does not match send list.

**Remedy:** Carry-out a POWER ON.

Reaction upon N: NONE  
 Acknowledge upon N: NONE  
 Reaction upon A: NONE  
 Acknowledge upon A: NONE

---

**F33887 (N, A) CU DRIVE-CLiQ: Component fault**

**Reaction:** A\_INFEED: NONE (OFF1, OFF2)  
 SERVO: OFF1 (DCBRAKE, NONE, OFF2, OFF3)  
 VECTOR: OFF1 (DCBRAKE, NONE, OFF2, OFF3)

**Acknowledge:** IMMEDIATELY

**Cause:** Fault detected on the DRIVE-CLiQ component involved. Faulty hardware cannot be excluded.  
 Fault value (r0949, interpret hexadecimal):  
 20: Error in the telegram header.  
 23: Receive error: The telegram buffer memory contains an error.  
 42: Send error: The telegram buffer memory contains an error.  
 43: Send error: The telegram buffer memory contains an error.  
 60: Response received too late during runtime measurement.  
 61: Time taken to exchange characteristic data too long.

**Remedy:** - check the DRIVE-CLiQ wiring (interrupted cable, contacts, ...).  
 - check the electrical cabinet design and cable routing for EMC compliance.  
 - if required, use another DRIVE-CLiQ socket (p9904).  
 - replace the component involved.

Reaction upon N: NONE  
 Acknowledge upon N: NONE  
 Reaction upon A: NONE  
 Acknowledge upon A: NONE

---

**F33895 (N, A) CU DRIVE-CLiQ: Cyclic data transfer error**

**Reaction:** A\_INFEED: NONE (OFF1, OFF2)  
 SERVO: OFF1 (DCBRAKE, NONE, OFF2, OFF3)  
 VECTOR: OFF1 (DCBRAKE, NONE, OFF2, OFF3)

**Acknowledge:** IMMEDIATELY

**Cause:** DRIVE-CLiQ communications error between the Control Unit and the encoder involved.  
 Fault value (r0949, interpret hexadecimal):  
 0B: Synchronization error during alternating cyclic data transfer.

**Remedy:** Carry-out a POWER ON.  
 See also: p9915 (DRIVE-CLiQ data transfer error, shutdown threshold, master)

Reaction upon N: NONE  
 Acknowledge upon N: NONE  
 Reaction upon A: NONE  
 Acknowledge upon A: NONE

---

**F33896 (N, A) CU DRIVE-CLiQ: Inconsistent component characteristics**

**Reaction:** A\_INFEED: NONE (OFF1, OFF2)  
SERVO: OFF2 (DCBRAKE, NONE, OFF1, OFF3, STOP1, STOP2)  
VECTOR: OFF2 (DCBRAKE, NONE, OFF1, OFF3, STOP1, STOP2)

**Acknowledge:** IMMEDIATELY

**Cause:** The properties of the DRIVE-CLiQ component, specified by the fault value, have changed in an incompatible fashion with respect to the properties when booted. One cause can be, e.g. that a DRIVE-CLiQ cable or DRIVE-CLiQ component has been replaced.  
Fault value (r0949, decimal):  
Component ID.

**Remedy:** - when replacing cables, only use cables with the same length as the original cables.  
- when replacing components, use the same components and firmware releases.  
- carry-out a POWER ON.

Reaction upon N: NONE  
Acknowledge upon N: NONE  
Reaction upon A: NONE  
Acknowledge upon A: NONE

---

**F33897 (N, A) DRIVE-CLiQ: No communication to component**

**Reaction:** A\_INFEED: NONE (OFF1, OFF2)  
SERVO: OFF1 (DCBRAKE, NONE, OFF2, OFF3, STOP1, STOP2)  
VECTOR: OFF1 (DCBRAKE, NONE, OFF2, OFF3, STOP1, STOP2)

**Acknowledge:** IMMEDIATELY (POWER ON)

**Cause:** Communications with the DRIVE-CLiQ component specified by the fault value is not possible.  
One cause can be, e.g. that a DRIVE-CLiQ cable has been withdrawn.  
Fault value (r0949, decimal):  
Component ID.

**Remedy:** - check the DRIVE-CLiQ connections.  
- carry-out a POWER ON.

Reaction upon N: NONE  
Acknowledge upon N: NONE  
Reaction upon A: NONE  
Acknowledge upon A: NONE

---

**F33899 (N, A) Encoder 3: Unknown fault**

**Reaction:** A\_INFEED: OFF2 (NONE, OFF1)  
SERVO: OFF1 (DCBRAKE, NONE, OFF2, OFF3, STOP1, STOP2)  
VECTOR: OFF1 (DCBRAKE, NONE, OFF2, OFF3, STOP1, STOP2)

**Acknowledge:** IMMEDIATELY (POWER ON)

**Cause:** A fault occurred on the Sensor Module for encoder 3 that cannot be interpreted by the Control Unit firmware.  
This can occur if the firmware on the Sensor Module for encoder 3 is more recent than the firmware on the Control Unit.  
Fault value (r0949, decimal):  
Fault number.  
If required, the significance of this new fault can be read about in a more recent description of the Control Unit.

**Remedy:** - replace the firmware on the Sensor Module by an older firmware version (r0148).  
- upgrade the firmware on the Control Unit (r0018).

Reaction upon N: NONE  
Acknowledge upon N: NONE  
Reaction upon A: NONE  
Acknowledge upon A: NONE

**F33905 (N, A) Encoder 3: Parameterization error**

**Reaction:** A\_INFEED: OFF2 (NONE, OFF1)  
 SERVO: OFF1 (DCBRAKE, NONE, OFF2, OFF3, STOP1, STOP2)  
 VECTOR: OFF1 (DCBRAKE, NONE, OFF2, OFF3, STOP1, STOP2)

**Acknowledge:** IMMEDIATELY

**Cause:** A parameter of encoder 3 was detected as being incorrect.  
 It is possible that the parameterized encoder type does not match the connected encoder.  
 The parameter involved can be determined as follows:  
 - determine the parameter number using the fault value (r0949).  
 - determine the parameter index (p0189).  
 Fault value (r0949, decimal):  
 Parameter number.

**Remedy:** - check whether the connected encoder type matches the encoder that has been parameterized.  
 - correct the parameter specified by the fault value (r0949) and p0189.

Reaction upon N: NONE  
 Acknowledge upon N: NONE  
 Reaction upon A: NONE  
 Acknowledge upon A: NONE

**A33920 (F, N) Encoder 3: Temperature sensor fault**

**Reaction:** NONE

**Acknowledge:** NONE

**Cause:** When evaluating the temperature sensor, an error occurred.  
 Alarm value (r2124, decimal):  
 1: Wire breakage or sensor not connected (KTY: R > 1630 Ohm).  
 2: Measured resistance too low (PTC: R < 20 Ohm, KTY: R < 50 Ohm).

**Remedy:** - check that the encoder cable is the correct type and is correctly connected.  
 - check the temperature sensor selection in p0600 to p0603.  
 - replace the Sensor Module (hardware defect or incorrect calibration data).

Reaction upon F: A\_INFEED: NONE (OFF1, OFF2)  
 SERVO: NONE (DCBRAKE, OFF1, OFF2, OFF3, STOP1, STOP2)  
 VECTOR: NONE (DCBRAKE, OFF1, OFF2, OFF3, STOP1, STOP2)

Acknowledge upon F: IMMEDIATELY

Reaction upon N: NONE  
 Acknowledge upon N: NONE

**A33999 (F, N) Encoder 3: Unknown alarm**

**Reaction:** NONE

**Acknowledge:** NONE

**Cause:** A alarm has occurred on the Sensor Module for encoder 3 that cannot be interpreted by the Control Unit firmware.  
 This can occur if the firmware on the Sensor Module for encoder 3 is more recent than the firmware on the Control Unit.  
 Alarm value (r2124, decimal):  
 Alarm number.  
 If required, the significance of this new alarm can be read about in a more recent description of the Control Unit.

**Remedy:** - replace the firmware on the Sensor Module by an older firmware version (r0148).  
 - upgrade the firmware on the Control Unit (r0018).

Reaction upon F: A\_INFEED: NONE (OFF1, OFF2)  
 SERVO: NONE (DCBRAKE, OFF1, OFF2, OFF3, STOP1, STOP2)  
 VECTOR: NONE (DCBRAKE, OFF1, OFF2, OFF3, STOP1, STOP2)

Acknowledge upon F: IMMEDIATELY (POWER ON)



Reaction upon N: NONE  
Acknowledge upon N: NONE

---

**F34207 (N, A) VSM: Temperature fault threshold exceeded**

**Reaction:** A\_INFEED: OFF2 (NONE, OFF1)  
SERVO: NONE  
VECTOR: NONE

**Acknowledge:** IMMEDIATELY (POWER ON)

**Cause:** The temperature (r3666) measured using the Voltage Sensing Module (VSM) has exceeded the threshold value (p3668).  
This fault can only be initiated if the temperature evaluation was activated (p3665 = 2 for a KTY sensor or p3665 = 1 for a PTC sensor).  
Fault value (r0949, decimal):  
The hundred thousands and ten thousands position specifies the component number of the VSM where the fault occurred.

**Remedy:** - check the fan.  
- reduce the power.

Reaction upon N: NONE  
Acknowledge upon N: NONE  
Reaction upon A: NONE  
Acknowledge upon A: NONE

---

**A34211 (F, N) VSM: Temperature alarm threshold exceeded**

**Reaction:** NONE

**Acknowledge:** NONE

**Cause:** The temperature (r3666) measured using the Voltage Sensing Module (VSM) has exceeded the threshold value (p3667).  
Alarm value (r2124, decimal):  
The hundred thousands and ten thousands position specifies the component number of the VSM where the fault occurred.

**Remedy:** - check the fan.  
- reduce the power.

Reaction upon F: A\_INFEED: NONE (OFF1, OFF2)  
SERVO: NONE  
VECTOR: NONE  
Acknowledge upon F: IMMEDIATELY (POWER ON)  
Reaction upon N: NONE  
Acknowledge upon N: NONE

---

**F34801 VSM DRIVE-CLiQ: Sign-of-life missing**

**Reaction:** A\_INFEED: OFF2 (NONE, OFF1)  
SERVO: NONE (OFF1, OFF2, OFF3)  
VECTOR: NONE (OFF1, OFF2, OFF3)

**Acknowledge:** IMMEDIATELY

**Cause:** A DRIVE-CLiQ communications error has occurred between the Control Unit and the Voltage Sensing Module (VSM).  
Fault value (r0949, interpret hexadecimal):  
0A: The sign-of-life bit in the receive telegram is not set.

**Remedy:** - check the DRIVE-CLiQ connection.  
- replace the Terminal Module.

<b>F34802</b>	<b>VSM: Time slice overflow</b>
<b>Reaction:</b>	A_INFEED: OFF2 (NONE, OFF1) SERVO: NONE (OFF1, OFF2, OFF3) VECTOR: NONE (OFF1, OFF2, OFF3)
<b>Acknowledge:</b>	IMMEDIATELY
<b>Cause:</b>	Time slice overflow on the Voltage Sensing Module.
<b>Remedy:</b>	Replace the Voltage Sensing Module.
<b>F34803</b>	<b>VSM: Memory test</b>
<b>Reaction:</b>	A_INFEED: OFF2 (NONE, OFF1) SERVO: NONE (OFF1, OFF2, OFF3) VECTOR: NONE (OFF1, OFF2, OFF3)
<b>Acknowledge:</b>	IMMEDIATELY
<b>Cause:</b>	An error has occurred during the memory test on the Voltage Sensing Module.
<b>Remedy:</b>	- check whether the permissible ambient temperature for the Voltage Sensing Module is being maintained. - replace the Voltage Sensing Module.
<b>F34804</b>	<b>VSM: CRC</b>
<b>Reaction:</b>	A_INFEED: OFF2 (NONE, OFF1) SERVO: NONE (OFF1, OFF2, OFF3) VECTOR: NONE (OFF1, OFF2, OFF3)
<b>Acknowledge:</b>	IMMEDIATELY
<b>Cause:</b>	A checksum error has occurred when reading-out the program memory on the Voltage Sensing Module (VSM).
<b>Remedy:</b>	- check whether the permissible ambient temperature for the component is maintained. - replace the Voltage Sensing Module.
<b>F34805</b>	<b>VSM: EPROM checksum error</b>
<b>Reaction:</b>	A_INFEED: OFF2 (NONE, OFF1) SERVO: NONE (OFF1, OFF2, OFF3) VECTOR: NONE (OFF1, OFF2, OFF3)
<b>Acknowledge:</b>	IMMEDIATELY
<b>Cause:</b>	Internal parameter data is corrupted. Fault value (r0949, interpret hexadecimal): 01: EEPROM access error. 02: Too many blocks in the EEPROM.
<b>Remedy:</b>	- check whether the permissible ambient temperature for the component is maintained. - replace the Voltage Sensing Module (VSM).
<b>F34806</b>	<b>VSM: Initialization</b>
<b>Reaction:</b>	A_INFEED: OFF2 (NONE, OFF1) SERVO: NONE (OFF1, OFF2, OFF3) VECTOR: NONE (OFF1, OFF2, OFF3)
<b>Acknowledge:</b>	IMMEDIATELY
<b>Cause:</b>	For the Voltage Sensing Module (VSM), a fault has occurred while initializing.
<b>Remedy:</b>	Replace the Voltage Sensing Module.
<b>A34807 (F, N)</b>	<b>VSM: Sequence control, time monitoring</b>
<b>Reaction:</b>	NONE
<b>Acknowledge:</b>	NONE
<b>Cause:</b>	Error, timeout in the sequence control on the Voltage Sensing Module (VSM).
<b>Remedy:</b>	Replace the Voltage Sensing Module.
Reaction upon F:	NONE
Acknowledge upon F:	IMMEDIATELY (POWER ON)

Reaction upon N: NONE  
Acknowledge upon N: NONE

---

**F34820 VSM DRIVE-CLiQ: Telegram error**

**Reaction:** A\_INFEED: OFF2 (NONE, OFF1)  
SERVO: NONE (OFF1, OFF2)  
VECTOR: NONE (OFF1, OFF2)

**Acknowledge:** IMMEDIATELY

**Cause:** A DRIVE-CLiQ communications error has occurred between the Control Unit and the Voltage Sensing Module.  
Fault value (r0949, interpret hexadecimal):  
01: CRC error.  
02: Telegram is shorter than specified in the length byte or in the receive list.  
03: Telegram is longer than specified in the length byte or in the receive list.  
04: The length of the receive telegram does not match the receive list.  
05: The type of the receive telegram does not match the receive list.  
06: The address of the encoder in the telegram and in the receive list do not match.  
07: The encoder expects a SYNC telegram, but the receive telegram is not a SYNC telegram.  
08: The encoder does not expect a SYNC telegram, but the receive telegram is a SYNC telegram.  
09: The error bit in the receive telegram is set.  
10: The receive telegram is too early.

**Remedy:** - carry-out a POWER ON.  
- check the electrical cabinet design and cable routing for EMC compliance.  
- check the DRIVE-CLiQ wiring (interrupted cable, contacts, ...).  
See also: p9916 (DRIVE-CLiQ data transfer error, shutdown threshold, slave)

---

**F34835 VSM DRIVE-CLiQ: Cyclic data transfer error**

**Reaction:** A\_INFEED: OFF2 (NONE, OFF1)  
SERVO: NONE (OFF1, OFF2)  
VECTOR: NONE (OFF1, OFF2)

**Acknowledge:** IMMEDIATELY

**Cause:** A DRIVE-CLiQ communications error has occurred between the Control Unit and the Voltage Sensing Module. The nodes do not send and receive in synchronism.  
Fault value (r0949, interpret hexadecimal):  
21: The cyclic telegram has not been received.  
22: Timeout in the telegram receive list.  
40: Timeout in the telegram send list.

**Remedy:** - carry-out a POWER ON.  
- replace the component involved.

---

**F34836 VSM DRIVE-CLiQ: Send error for DRIVE-CLiQ data**

**Reaction:** A\_INFEED: OFF2 (NONE, OFF1)  
SERVO: NONE (OFF1, OFF2)  
VECTOR: NONE (OFF1, OFF2)

**Acknowledge:** IMMEDIATELY

**Cause:** A DRIVE-CLiQ communications error has occurred between the Control Unit and the Voltage Sensing Module. Data were not able to be sent.  
Fault value (r0949, interpret hexadecimal):  
41: Telegram type does not match send list.

**Remedy:** Carry-out a POWER ON.

---

**F34837 VSM DRIVE-CLiQ: Component fault**

**Reaction:** A\_INFEED: OFF2 (NONE, OFF1)  
SERVO: NONE (OFF1, OFF2)  
VECTOR: NONE (OFF1, OFF2)

**Acknowledge:** IMMEDIATELY

**Cause:** Fault detected on the DRIVE-CLiQ component involved. Faulty hardware cannot be excluded.  
 Fault value (r0949, interpret hexadecimal):  
 20: Error in the telegram header.  
 23: Receive error: The telegram buffer memory contains an error.  
 42: Send error: The telegram buffer memory contains an error.  
 43: Send error: The telegram buffer memory contains an error.

**Remedy:**

- check the DRIVE-CLiQ wiring (interrupted cable, contacts, ...).
- check the electrical cabinet design and cable routing for EMC compliance.
- if required, use another DRIVE-CLiQ socket (p9904).
- replace the component involved.

---

**F34845 VSM DRIVE-CLiQ: Cyclic data transfer error**

**Reaction:** A\_INFEED: OFF2 (NONE, OFF1)  
 SERVO: NONE (OFF1, OFF2)  
 VECTOR: NONE (OFF1, OFF2)

**Acknowledge:** IMMEDIATELY

**Cause:** A DRIVE-CLiQ communications error has occurred between the Control Unit and the Voltage Sensing Module (VSM).  
 Fault value (r0949, interpret hexadecimal):  
 0B: Synchronization error during alternating cyclic data transfer.

**Remedy:** Carry-out a POWER ON.  
 See also: p9916 (DRIVE-CLiQ data transfer error, shutdown threshold, slave)

---

**F34850 VSM: Internal software error**

**Reaction:** A\_INFEED: OFF1 (NONE, OFF2)  
 SERVO: OFF1 (NONE, OFF2, OFF3)  
 VECTOR: OFF1 (NONE, OFF2, OFF3)

**Acknowledge:** POWER ON

**Cause:** An internal software error in the Voltage Sensing Module (VSM) has occurred.  
 Fault value (r0949, decimal):  
 1: Background time slice is blocked.  
 2: Checksum over the code memory is not OK.

**Remedy:**

- replace the Voltage Sensing Module (VSM).
- if required, upgrade the firmware in the Voltage Sensing Module.
- contact the Hotline.

---

**F34851 CU DRIVE-CLiQ: Sign-of-life missing**

**Reaction:** A\_INFEED: OFF2 (NONE, OFF1)  
 SERVO: NONE (OFF1, OFF2)  
 VECTOR: NONE (OFF1, OFF2)

**Acknowledge:** IMMEDIATELY

**Cause:** A DRIVE-CLiQ communications error has occurred between the Control Unit and the Voltage Sensing Module (VSM). The DRIVE-CLiQ component did not set the sign of life to the Control Unit.  
 Fault value (r0949, interpret hexadecimal):  
 0A: The sign-of-life bit in the receive telegram is not set.

**Remedy:** Upgrade the firmware of the component involved.

---

**F34860 CU DRIVE-CLiQ: Telegram error**

**Reaction:** A\_INFEED: OFF2 (NONE, OFF1)  
 SERVO: NONE (OFF1, OFF2)  
 VECTOR: NONE (OFF1, OFF2)

**Acknowledge:** IMMEDIATELY

**Cause:** A DRIVE-CLiQ communications error has occurred between the Control Unit and the Voltage Sensing Module.  
 Fault value (r0949, interpret hexadecimal):  
 11: CRC error and the receive telegram is too early.  
 01: CRC error.  
 12: The telegram is shorter than that specified in the length byte or in the receive list and the receive telegram is too early.

- 02: Telegram is shorter than specified in the length byte or in the receive list.
- 13: The telegram is longer than that specified in the length byte or in the receive list and the receive telegram is too early.
- 03: Telegram is longer than specified in the length byte or in the receive list.
- 14: The length of the receive telegram does not match the receive list and the receive telegram is too early.
- 04: The length of the receive telegram does not match the receive list.
- 15: The type of the receive telegram does not match the receive list and the receive telegram is too early.
- 05: The type of the receive telegram does not match the receive list.
- 16: The address of the Voltage Sensing Module in the telegram and in the receive list does not match and the receive telegram is too early.
- 06: The address of the Voltage Sensing Module in the telegram and in the receive list do not match.
- 19: The error bit in the receive telegram is set and the receive telegram is too early.
- 09: The error bit in the receive telegram is set.
- 10: The receive telegram is too early.

**Remedy:**

- carry-out a POWER ON.
- check the electrical cabinet design and cable routing for EMC compliance.
- check the DRIVE-CLiQ wiring (interrupted cable, contacts, ...).

See also: p9915 (DRIVE-CLiQ data transfer error, shutdown threshold, master)

**F34885 CU DRIVE-CLiQ: Cyclic data transfer error**

**Reaction:** A\_INFEED: OFF2 (NONE, OFF1)  
 SERVO: NONE (OFF1, OFF2)  
 VECTOR: NONE (OFF1, OFF2)

**Acknowledge:** IMMEDIATELY

**Cause:** A DRIVE-CLiQ communications error has occurred between the Control Unit and the Voltage Sensing Module. The nodes do not send and receive in synchronism.  
 Fault value (r0949, interpret hexadecimal):  
 1A: Sign-of-life bit in the receive telegram not set and the receive telegram is too early.  
 21: The cyclic telegram has not been received.  
 22: Timeout in the telegram receive list.  
 40: Timeout in the telegram send list.  
 62: Error at the transition to cyclic operation.

**Remedy:**

- check the power supply voltage of the component involved.
- carry-out a POWER ON.
- replace the component involved.

See also: p9915 (DRIVE-CLiQ data transfer error, shutdown threshold, master)

**F34886 CU DRIVE-CLiQ: Error when sending DRIVE-CLiQ data**

**Reaction:** A\_INFEED: OFF2 (NONE, OFF1)  
 SERVO: NONE (OFF1, OFF2)  
 VECTOR: NONE (OFF1, OFF2)

**Acknowledge:** IMMEDIATELY

**Cause:** A DRIVE-CLiQ communications error has occurred between the Control Unit and the VSM involved. Data were not able to be sent.  
 Fault value (r0949, interpret hexadecimal):  
 41: Telegram type does not match send list.

**Remedy:** Carry-out a POWER ON.

**F34887 CU DRIVE-CLiQ: Component fault**

**Reaction:** A\_INFEED: OFF2 (NONE, OFF1)  
 SERVO: NONE (OFF1, OFF2)  
 VECTOR: NONE (OFF1, OFF2)

**Acknowledge:** IMMEDIATELY

**Cause:** Fault detected on the DRIVE-CLiQ component involved. Faulty hardware cannot be excluded.  
 Fault value (r0949, interpret hexadecimal):  
 20: Error in the telegram header.  
 23: Receive error: The telegram buffer memory contains an error.  
 42: Send error: The telegram buffer memory contains an error.  
 43: Send error: The telegram buffer memory contains an error.  
 60: Response received too late during runtime measurement.  
 61: Time taken to exchange characteristic data too long.

- Remedy:**
- check the DRIVE-CLiQ wiring (interrupted cable, contacts, ...).
  - check the electrical cabinet design and cable routing for EMC compliance.
  - if required, use another DRIVE-CLiQ socket (p9904).
  - replace the component involved.

---

**F34895 CU DRIVE-CLiQ: Cyclic data transfer error**

- Reaction:** A\_INFEED: OFF2 (NONE, OFF1)  
SERVO: NONE (OFF1, OFF2), VECTOR: NONE (OFF1, OFF2)
- Acknowledge:** IMMEDIATELY
- Cause:** A DRIVE-CLiQ communications error has occurred between the Control Unit and the Voltage Sensing Module.  
Fault value (r0949, interpret hexadecimal):  
0B: Synchronization error during alternating cyclic data transfer.
- Remedy:** Carry-out a POWER ON.  
See also: p9915 (DRIVE-CLiQ data transfer error, shutdown threshold, master)

---

**F34896 CU DRIVE-CLiQ: Inconsistent component characteristics**

- Reaction:** A\_INFEED: OFF2 (NONE, OFF1)  
SERVO: OFF2 (DCBRAKE, NONE, OFF1, OFF3, STOP1, STOP2)  
VECTOR: OFF2 (DCBRAKE, NONE, OFF1, OFF3, STOP1, STOP2)
- Acknowledge:** IMMEDIATELY
- Cause:** The properties of the DRIVE-CLiQ component, specified by the fault value, have changed in an incompatible fashion with respect to the properties when booted. One cause can be, e.g. that a DRIVE-CLiQ cable or DRIVE-CLiQ component has been replaced.  
Fault value (r0949, decimal):  
Component ID.
- Remedy:**
- when replacing cables, only use cables with the same length as the original cables.
  - when replacing components, use the same components and firmware releases.
  - carry-out a POWER ON.

---

**F34897 DRIVE-CLiQ: No communication to component**

- Reaction:** A\_INFEED: OFF2 (NONE, OFF1)  
SERVO: OFF2 (DCBRAKE, ENCODER, NONE, OFF1, OFF3, STOP1, STOP2)  
VECTOR: OFF2 (DCBRAKE, ENCODER, NONE, OFF1, OFF3, STOP1, STOP2)
- Acknowledge:** IMMEDIATELY (POWER ON)
- Cause:** Communications with the DRIVE-CLiQ component specified by the fault value is not possible.  
One cause can be, e.g. that a DRIVE-CLiQ cable has been withdrawn.  
Fault value (r0949, decimal):  
Component ID.
- Remedy:**
- check the DRIVE-CLiQ connections.
  - carry-out a POWER ON.

---

**F34899 (N, A) VSM: Unknown fault**

- Reaction:** A\_INFEED: NONE (OFF1, OFF2)  
SERVO: NONE (OFF1, OFF2, OFF3)  
VECTOR: NONE (OFF1, OFF2, OFF3)
- Acknowledge:** IMMEDIATELY (POWER ON)
- Cause:** A fault occurred on the Voltage Sensing Module that cannot be interpreted by the Control Unit firmware. This can occur if the firmware on the Voltage Sensing Module is more recent than the firmware on the Control Unit.  
Fault value (r0949, decimal):  
Fault number.  
If required, the significance of this new fault can be read about in a more recent description of the Control Unit.
- Remedy:**
- replace the firmware on the Voltage Sensing Module by an older firmware version (r0xyz).
  - upgrade the firmware on the Control Unit (r0018).
- Reaction upon N: NONE  
Acknowledge upon N: NONE  
Reaction upon A: NONE  
Acknowledge upon A: NONE

---

**A34903 (F, N) VSM: Error I2C bus**

**Reaction:** NONE  
**Acknowledge:** NONE  
**Cause:** An error has occurred in while accessing via the internal TM I2C bus.  
**Remedy:** Replace the Terminal Module.  
Reaction upon F: A\_INFEED: NONE (OFF1, OFF2)  
SERVO: NONE  
VECTOR: NONE  
Acknowledge upon F: IMMEDIATELY (POWER ON)  
Reaction upon N: NONE  
Acknowledge upon N: NONE

---

**A34904 (F, N) VSM: EEPROM**

**Reaction:** NONE  
**Acknowledge:** NONE  
**Cause:** An error has occurred accessing the non-volatile memory on the Terminal Module.  
**Remedy:** Replace the Terminal Module.  
Reaction upon F: A\_INFEED: NONE (OFF1, OFF2)  
SERVO: NONE  
VECTOR: NONE  
Acknowledge upon F: IMMEDIATELY (POWER ON)  
Reaction upon N: NONE  
Acknowledge upon N: NONE

---

**A34905 (F, N) VSM: Parameter access**

**Reaction:** NONE  
**Acknowledge:** NONE  
**Cause:** The Control Unit attempted to write an illegal parameter value into the Voltage Sensing Module (VSM).  
**Remedy:** - check whether the firmware version of the VSM (r0158) matches the firmware version of Control Unit (r0018).  
- if required, replace the Voltage Sensing Module.  
Note:  
The firmware versions that match each other are in the readme.txt file on the CompactFlash card.  
Reaction upon F: A\_INFEED: NONE (OFF1, OFF2)  
SERVO: NONE  
VECTOR: NONE  
Acknowledge upon F: IMMEDIATELY (POWER ON)  
Reaction upon N: NONE  
Acknowledge upon N: NONE

---

**A34920 (F, N) VSM: Temperature sensor fault**

**Reaction:** NONE  
**Acknowledge:** NONE  
**Cause:** When evaluating the temperature sensor, an error occurred.  
Alarm value (r2124, decimal):  
1: Wire breakage or sensor not connected (KTY: R > 1630 Ohm).  
2: Measured resistance too low (PTC: R < 20 Ohm, KTY: R < 50 Ohm).  
**Remedy:** - check that the sensor is connected correctly.  
- replace sensor.

Reaction upon F: A\_INFEED: NONE (OFF1, OFF2)  
 SERVO: NONE  
 VECTOR: NONE

Acknowledge upon F: IMMEDIATELY (POWER ON)

Reaction upon N: NONE

Acknowledge upon N: NONE

---

**A34999 (F, N) VSM: Unknown alarm**

**Reaction:** NONE

**Acknowledge:** NONE

**Cause:** A fault occurred on the Voltage Sensing Module (VSM) an alarm has occurred that cannot be interpreted by the Control Unit firmware.  
 This can occur if the firmware on the module is more recent than the firmware on the Control Unit.  
 Alarm value (r2124, decimal):  
 Alarm number.  
 If required, the significance of this new alarm can be read about in a more recent description of the Control Unit.

**Remedy:**  
 - replace the firmware on the Voltage Sensing Module by an older firmware version (r0148).  
 - upgrade the firmware on the Control Unit (r0018).

Reaction upon F: A\_INFEED: NONE (OFF1, OFF2)  
 SERVO: NONE (OFF1, OFF2, OFF3)  
 VECTOR: NONE (OFF1, OFF2, OFF3)

Acknowledge upon F: IMMEDIATELY (POWER ON)

Reaction upon N: NONE

Acknowledge upon N: NONE

---

**A35200 (F, N) TM: Calibration data**

**Reaction:** NONE

**Acknowledge:** NONE

**Cause:** An error was detected in the calibration data of the Terminal Module.  
 Alarm value (r2124, decimal):  
 The hundred thousands and ten thousands location specifies the component Id of the Terminal Module where the fault occurred.  
 The thousands location specifies whether the analog input 0 (=0) or analog output 1 (= 1) is involved.  
 The hundreds location specifies the fault type:  
 0: No calibration data available.  
 1: Offset too high (> 100 mV).  
 The tens and ones location specifies the number of the input involved.

**Remedy:** Power-down the unit and power-up again.  
 If the fault is still present, replace the module/board.

Reaction upon F: NONE

Acknowledge upon F: IMMEDIATELY (POWER ON)

Reaction upon N: NONE

Acknowledge upon N: NONE



**F35207 (N, A) TM: Temperature fault threshold exceeded**

**Reaction:** A\_INFEED: OFF2 (NONE, OFF1)  
SERVO: OFF2 (NONE, OFF1, OFF3)  
VECTOR: OFF2 (NONE, OFF1, OFF3)

**Acknowledge:** IMMEDIATELY (POWER ON)

**Cause:** The temperature measured using the temperature sensing of the Terminal Module (TM) (r4105) has exceeded the threshold value to initiate this fault (p4102[1]).  
Please note that this fault can only be initiated if the temperature evaluation was activated (p4100 = 2 for KTY sensor or p4100 = 1 for PTC sensor).  
Fault value (r0949, decimal):  
The hundred thousands and ten thousands location specifies the component number of the TMxx where the fault occurred.  
Alarm:  
Please note that Fault F35207 only causes the drive to be shut down if there is at least one BICO interconnection between the drive and TM31.

**Remedy:** - allow the temperature sensor to cool down.  
- if required, set the fault response to NONE (p2100, p2101).

Reaction upon N: NONE  
Acknowledge upon N: NONE  
Reaction upon A: NONE  
Acknowledge upon A: NONE

**A35211 (F, N) TM: Temperature alarm threshold exceeded**

**Reaction:** NONE

**Acknowledge:** NONE

**Cause:** The temperature measured using the temperature sensing of the Terminal Module (TM) (r4105) has exceeded the threshold value to initiate this alarm (p4102[0]).  
Alarm value (r2124, decimal):  
The hundred thousands and ten thousands location specifies the component number of the TMxx where the fault occurred.

**Remedy:** Allow the temperature sensor to cool down.

Reaction upon F: NONE  
Acknowledge upon F: IMMEDIATELY (POWER ON)  
Reaction upon N: NONE  
Acknowledge upon N: NONE

**F35220 (N, A) TM: Frequency limit reached for signal output**

**Reaction:** A\_INFEED: OFF1 (NONE, OFF2)  
SERVO: OFF1 (NONE, OFF2, OFF3)  
VECTOR: OFF1 (NONE, OFF2, OFF3)

**Acknowledge:** IMMEDIATELY (POWER ON)

**Cause:** The signals output from the Terminal Module 41 (TM41) for tracks A/B have reached the limit frequency. The output signals are no longer in synchronism with the specified setpoint.

**Remedy:** - enter a lower speed setpoint (p1155).  
- reduce the encoder pulse number (p0408).

Reaction upon N: NONE  
Acknowledge upon N: NONE  
Reaction upon A: NONE  
Acknowledge upon A: NONE

**F35221 (N, A) TM: Setpoint - actual value deviation, outside the tolerance range**

**Reaction:** A\_INFEED: OFF1 (NONE, OFF2)  
 SERVO: OFF1 (NONE, OFF2, OFF3)  
 VECTOR: OFF1 (NONE, OFF2, OFF3)

**Acknowledge:** IMMEDIATELY (POWER ON)

**Cause:** The deviation between the setpoint and the output signals (track A/B) exceeds the tolerance of +/-3 %.

**Remedy:** - reduce the basic clock cycle (p0110, p0111).  
 - replace the module.

Reaction upon N: NONE  
 Acknowledge upon N: NONE

Reaction upon A: NONE  
 Acknowledge upon A: NONE

**A35222 (F, N) TM: Encoder pulse number not permissible**

**Reaction:** NONE

**Acknowledge:** NONE

**Cause:** The encoder pulse number entered does not match the permissible pulse number from a hardware perspective.  
 Fault value (r0949, decimal):  
 1: Encoder pulse number is too high.  
 2: Encoder pulse number is too low.  
 4: Encoder pulse number is less than the zero mark offset (p4426)

**Remedy:** Enter the encoder pulse number in the permissible range (p0408).

Reaction upon F: A\_INFEED: OFF1 (NONE, OFF2)  
 SERVO: OFF1 (NONE, OFF2, OFF3)  
 VECTOR: OFF1 (NONE, OFF2, OFF3)

Acknowledge upon F: IMMEDIATELY (POWER ON)

Reaction upon N: NONE  
 Acknowledge upon N: NONE

**A35223 (F, N) TM: ZM offset not permissible**

**Reaction:** NONE

**Acknowledge:** NONE

**Cause:** The entered zero mark offset is not permissible.  
 Fault value (r0949, decimal):  
 1: Zero mark offset is too high.  
 See also: p4426 (Incremental encoder emulation, pulses for zero mark)

**Remedy:** Enter the zero mark offset in the permissible range (p4426).

Reaction upon F: A\_INFEED: OFF1 (NONE, OFF2)  
 SERVO: OFF1 (NONE, OFF2, OFF3)  
 VECTOR: OFF1 (NONE, OFF2, OFF3)

Acknowledge upon F: IMMEDIATELY (POWER ON)

Reaction upon N: NONE  
 Acknowledge upon N: NONE

---

<b>A35224 (N)</b>	<b>TM: Zero mark synchronization interrupted</b>
<b>Reaction:</b>	NONE
<b>Acknowledge:</b>	NONE
<b>Cause:</b>	The zero mark synchronization with the encoder to be emulated was interrupted. Alarm value (r2124, decimal): 0: The encoder is not in the ready state (e.g. encoder parked) 1: An absolute encoder was connected. 2: The encoder r0479[0...2] interconnected with CI: p4420 is already communicating with another TM41 (precisely one TM41 can be interconnected with a specific r0479[0...2]). 3: The BICO interconnection to TM41 was removed (CI: p4420 = 0 signal). 4: The encoder connected with CI: p4420 has carried-out an EDS changeover (this operation is not supported, set p4420 to 0 and interconnect again). 5: The maximum number of revolutions of the encoder was exceeded. 6: Encoder in an invalid state. 7: Encoder in an invalid state.
<b>Remedy:</b>	None necessary. - if the encoder changes into the ready state, then a synchronization operation that was previously interrupted is carried-out again. - if the synchronization was interrupted due to the maximum permissible synchronization duration, then a new synchronization is not carried-out. - for an absolute encoder, no synchronization is carried-out, the zero mark is always output at the zero revolution of the TM41.
Reaction upon N:	NONE
Acknowledge upon N:	NONE

---

<b>A35225</b>	<b>TM: Zero mark synchronization held - encoder not in the ready state</b>
<b>Reaction:</b>	NONE
<b>Acknowledge:</b>	NONE
<b>Cause:</b>	The zero mark synchronization with the encoder to be emulated was held. The encoder is not in the "ready" state.
<b>Remedy:</b>	Bring the encoder into the "ready" state.

---

<b>A35226</b>	<b>TM: Tracks A/B are de-activated</b>
<b>Reaction:</b>	NONE
<b>Acknowledge:</b>	NONE
<b>Cause:</b>	The output of tracks A/B of the TM41 has been held (frozen). - there was no interconnection established from CI: p4420. - the encoder is not in the "ready" state. - TM41 has a fault condition.
<b>Remedy:</b>	- establish an interconnection from CI: p4420. - bring the encoder into the "ready" state. - remove any TM41 faults.

---

<b>A35227</b>	<b>TM: Zero mark synchronization interrupted - EDS changeover not supported</b>
<b>Reaction:</b>	NONE
<b>Acknowledge:</b>	NONE
<b>Cause:</b>	The interconnected encoder has carried-out an EDS changeover. TM41 does not support this particular application case.
<b>Remedy:</b>	The BICO interconnection must be re-established (CI: p4420).

---

**A35801 (F, N) TM DRIVE-CLiQ: Sign-of-life missing**

**Reaction:** NONE  
**Acknowledge:** NONE  
**Cause:** A DRIVE-CLiQ communications error has occurred between the Control Unit and the Terminal Module involved.  
 Alarm value (r2124, interpret hexadecimal):  
 0A: The sign-of-life bit in the receive telegram is not set.  
**Remedy:** - check the DRIVE-CLiQ connection.  
 - replace the component involved.  
 See also: p9916 (DRIVE-CLiQ data transfer error, shutdown threshold, slave)  
 Reaction upon F: NONE  
 Acknowledge upon F: IMMEDIATELY  
 Reaction upon N: NONE  
 Acknowledge upon N: NONE

---

**A35802 (F, N) TM: Time slice overflow**

**Reaction:** NONE  
**Acknowledge:** NONE  
**Cause:** Time slice overflow on Terminal Module.  
**Remedy:** Replace the Terminal Module.  
 Reaction upon F: NONE  
 Acknowledge upon F: IMMEDIATELY (POWER ON)  
 Reaction upon N: NONE  
 Acknowledge upon N: NONE

---

**A35803 (F, N) TM: Memory test**

**Reaction:** NONE  
**Acknowledge:** NONE  
**Cause:** An error has occurred during the memory test on the Terminal Module.  
**Remedy:** - check whether the permissible ambient temperature for the Terminal Module is being maintained.  
 - replace the Terminal Module.  
 Reaction upon F: NONE  
 Acknowledge upon F: IMMEDIATELY (POWER ON)  
 Reaction upon N: NONE  
 Acknowledge upon N: NONE

---

**A35804 (F, N) TM: CRC**

**Reaction:** NONE  
**Acknowledge:** NONE  
**Cause:** A checksum error has occurred when reading-out the program memory on the Terminal Module.  
 Fault value (r0949, interpret hexadecimal):  
 Difference between the checksum at POWER ON and the actual checksum.  
**Remedy:** - check whether the permissible ambient temperature for the component is maintained.  
 - replace the Terminal Module.  
 Reaction upon F: NONE  
 Acknowledge upon F: IMMEDIATELY (POWER ON)  
 Reaction upon N: NONE  
 Acknowledge upon N: NONE

---

<b>A35805 (F, N)</b>	<b>TM: EPROM checksum error</b>
<b>Reaction:</b>	NONE
<b>Acknowledge:</b>	NONE
<b>Cause:</b>	Internal parameter data is corrupted. Alarm value (r2124, interpret hexadecimal): 01: EEPROM access error. 02: Too many blocks in the EEPROM.
<b>Remedy:</b>	- check whether the permissible ambient temperature for the component is maintained. - replace the Terminal Module 31 (TM31).
Reaction upon F:	NONE
Acknowledge upon F:	IMMEDIATELY (POWER ON)
Reaction upon N:	NONE
Acknowledge upon N:	NONE

---

<b>A35807 (F, N)</b>	<b>TM: Sequence control, time monitoring</b>
<b>Reaction:</b>	NONE
<b>Acknowledge:</b>	NONE
<b>Cause:</b>	Error, timeout, sequence control on the Terminal Module.
<b>Remedy:</b>	Replace the Terminal Module.
Reaction upon F:	NONE
Acknowledge upon F:	IMMEDIATELY (POWER ON)
Reaction upon N:	NONE
Acknowledge upon N:	NONE

---

<b>F35820</b>	<b>TM DRIVE-CLiQ: Telegram error</b>
<b>Reaction:</b>	OFF1 (OFF2)
<b>Acknowledge:</b>	IMMEDIATELY
<b>Cause:</b>	A DRIVE-CLiQ communications error has occurred between the Control Unit and the Terminal Module involved. Fault value (r0949, interpret hexadecimal): 01: CRC error. 02: Telegram is shorter than specified in the length byte or in the receive list. 03: Telegram is longer than specified in the length byte or in the receive list. 04: The length of the receive telegram does not match the receive list. 05: The type of the receive telegram does not match the receive list. 06: The address of the Terminal Module in the telegram and in the receive list do not match. 07: Terminal Module expects a SYNC telegram, but the receive telegram is not a SYNC telegram. 08: Terminal Module does not expect a SYNC telegram, but the receive telegram is a SYNC telegram. 09: The error bit in the receive telegram is set. 10: The receive telegram is too early.
<b>Remedy:</b>	- carry-out a POWER ON. - check the electrical cabinet design and cable routing for EMC compliance. - check the DRIVE-CLiQ wiring (interrupted cable, contacts, ...). See also: p9916 (DRIVE-CLiQ data transfer error, shutdown threshold, slave)

---

<b>F35835</b>	<b>TM DRIVE-CLiQ: Cyclic data transfer error</b>
<b>Reaction:</b>	OFF1 (OFF2)
<b>Acknowledge:</b>	IMMEDIATELY
<b>Cause:</b>	A DRIVE-CLiQ communications error has occurred between the Control Unit and the Terminal Module involved. The nodes do not send and receive in synchronism. Fault value (r0949, interpret hexadecimal): 21: The cyclic telegram has not been received. 22: Timeout in the telegram receive list. 40: Timeout in the telegram send list.

**Remedy:**

- carry-out a POWER ON.
- replace the component involved.

See also: p9916 (DRIVE-CLiQ data transfer error, shutdown threshold, slave)

---

**F35836      TM DRIVE-CLiQ: Send error for DRIVE-CLiQ data**

**Reaction:**      OFF1 (OFF2)  
**Acknowledge:**    IMMEDIATELY  
**Cause:**          A DRIVE-CLiQ communications error has occurred between the Control Unit and the Terminal Module involved. Data were not able to be sent.  
 Fault value (r0949, interpret hexadecimal):  
 41: Telegram type does not match send list.  
**Remedy:**          Carry-out a POWER ON.

---

**F35837      PTM DRIVE-CLiQ: Component fault**

**Reaction:**      OFF1 (OFF2)  
**Acknowledge:**    IMMEDIATELY  
**Cause:**          Fault detected on the DRIVE-CLiQ component involved. Faulty hardware cannot be excluded.  
 Fault value (r0949, interpret hexadecimal):  
 20: Error in the telegram header.  
 23: Receive error: The telegram buffer memory contains an error.  
 42: Send error: The telegram buffer memory contains an error.  
 43: Send error: The telegram buffer memory contains an error.  
**Remedy:**          - check the DRIVE-CLiQ wiring (interrupted cable, contacts, ...).  
 - check the electrical cabinet design and cable routing for EMC compliance.  
 - if required, use another DRIVE-CLiQ socket (p9904).  
 - replace the component involved.

---

**F35845      TM DRIVE-CLiQ: Cyclic data transfer error**

**Reaction:**      OFF1 (OFF2)  
**Acknowledge:**    IMMEDIATELY  
**Cause:**          A DRIVE-CLiQ communications error has occurred between the Control Unit and the Terminal Module (TM) involved.  
 Fault value (r0949, interpret hexadecimal):  
 0B: Synchronization error during alternating cyclic data transfer.  
**Remedy:**          Carry-out a POWER ON.  
 See also: p9916 (DRIVE-CLiQ data transfer error, shutdown threshold, slave)

---

**F35850      TM: Internal software error**

**Reaction:**      A\_INFEED: OFF1 (NONE, OFF2)  
                   SERVO: OFF1 (NONE, OFF2, OFF3)  
                   VECTOR: OFF1 (NONE, OFF2, OFF3)  
**Acknowledge:**    POWER ON  
**Cause:**          An internal software error in the Terminal Module (TM) has occurred.  
 Fault value (r0949, decimal):  
 1: Background time slice is blocked.  
 2: Checksum over the code memory is not OK.  
**Remedy:**          - replace the Terminal Module (TM).  
 - if required, upgrade the firmware in the Terminal Module.  
 - contact the Hotline.

---

**F35851      CU DRIVE-CLiQ: Sign-of-life missing**

**Reaction:**      OFF1 (OFF2)  
**Acknowledge:**    IMMEDIATELY  
**Cause:**          A DRIVE-CLiQ communications error has occurred between the Control Unit and the Terminal Module (TM) involved. The DRIVE-CLiQ component did not set the sign of life to the Control Unit.  
 Fault value (r0949, interpret hexadecimal):  
 0A: The sign-of-life bit in the receive telegram is not set.  
**Remedy:**          Upgrade the firmware of the component involved.

---

<b>F35860</b>	<b>CU DRIVE-CLiQ: Telegram error</b>
<b>Reaction:</b>	OFF1 (OFF2)
<b>Acknowledge:</b>	IMMEDIATELY
<b>Cause:</b>	<p>A DRIVE-CLiQ communications error has occurred between the Control Unit and the Terminal Module involved.</p> <p>Fault value (r0949, interpret hexadecimal):</p> <p>11: CRC error and the receive telegram is too early.</p> <p>01: CRC error.</p> <p>12: The telegram is shorter than that specified in the length byte or in the receive list and the receive telegram is too early.</p> <p>02: Telegram is shorter than specified in the length byte or in the receive list.</p> <p>13: The telegram is longer than that specified in the length byte or in the receive list and the receive telegram is too early.</p> <p>03: Telegram is longer than specified in the length byte or in the receive list.</p> <p>14: The length of the receive telegram does not match the receive list and the receive telegram is too early.</p> <p>04: The length of the receive telegram does not match the receive list.</p> <p>15: The type of the receive telegram does not match the receive list and the receive telegram is too early.</p> <p>05: The type of the receive telegram does not match the receive list.</p> <p>16: The address of the Terminal Module in the telegram and in the receive list does not match and the receive telegram is too early.</p> <p>06: The address of the Terminal Module in the telegram and in the receive list do not match.</p> <p>19: The error bit in the receive telegram is set and the receive telegram is too early.</p> <p>09: The error bit in the receive telegram is set.</p> <p>10: The receive telegram is too early.</p>
<b>Remedy:</b>	<ul style="list-style-type: none"> <li>- carry-out a POWER ON.</li> <li>- check the electrical cabinet design and cable routing for EMC compliance.</li> <li>- check the DRIVE-CLiQ wiring (interrupted cable, contacts, ...).</li> </ul> <p>See also: p9915 (DRIVE-CLiQ data transfer error, shutdown threshold, master)</p>

---

<b>F35885</b>	<b>CU DRIVE-CLiQ: Cyclic data transfer error</b>
<b>Reaction:</b>	OFF1 (OFF2)
<b>Acknowledge:</b>	IMMEDIATELY
<b>Cause:</b>	<p>A DRIVE-CLiQ communications error has occurred between the Control Unit and the Terminal Module involved. The nodes do not send and receive in synchronism.</p> <p>Fault value (r0949, interpret hexadecimal):</p> <p>1A: Sign-of-life bit in the receive telegram not set and the receive telegram is too early.</p> <p>21: The cyclic telegram has not been received.</p> <p>22: Timeout in the telegram receive list.</p> <p>40: Timeout in the telegram send list.</p> <p>62: Error at the transition to cyclic operation.</p>
<b>Remedy:</b>	<ul style="list-style-type: none"> <li>- check the power supply voltage of the component involved.</li> <li>- carry-out a POWER ON.</li> <li>- replace the component involved.</li> </ul> <p>See also: p9915 (DRIVE-CLiQ data transfer error, shutdown threshold, master)</p>

---

<b>F35886</b>	<b>CU DRIVE-CLiQ: Error when sending DRIVE-CLiQ data</b>
<b>Reaction:</b>	OFF1 (OFF2)
<b>Acknowledge:</b>	IMMEDIATELY
<b>Cause:</b>	<p>A DRIVE-CLiQ communications error has occurred between the Control Unit and the Terminal Module involved.</p> <p>Data were not able to be sent.</p> <p>Fault value (r0949, interpret hexadecimal):</p> <p>41: Telegram type does not match send list.</p>
<b>Remedy:</b>	Carry-out a POWER ON.

<b>F35887</b>	<b>CU DRIVE-CLiQ: Component fault</b>
<b>Reaction:</b>	OFF1 (OFF2)
<b>Acknowledge:</b>	IMMEDIATELY
<b>Cause:</b>	Fault detected on the DRIVE-CLiQ component involved. Faulty hardware cannot be excluded. Fault value (r0949, interpret hexadecimal): 20: Error in the telegram header. 23: Receive error: The telegram buffer memory contains an error. 42: Send error: The telegram buffer memory contains an error. 43: Send error: The telegram buffer memory contains an error. 60: Response received too late during runtime measurement. 61: Time taken to exchange characteristic data too long.
<b>Remedy:</b>	- check the DRIVE-CLiQ wiring (interrupted cable, contacts, ...). - check the electrical cabinet design and cable routing for EMC compliance. - if required, use another DRIVE-CLiQ socket (p9904). - replace the component involved.
<b>F35895</b>	<b>CU DRIVE-CLiQ: Cyclic data transfer error</b>
<b>Reaction:</b>	OFF1 (OFF2)
<b>Acknowledge:</b>	IMMEDIATELY
<b>Cause:</b>	A DRIVE-CLiQ communications error has occurred between the Control Unit and the Terminal Module involved. Fault value (r0949, interpret hexadecimal): 0B: Synchronization error during alternating cyclic data transfer.
<b>Remedy:</b>	Carry-out a POWER ON. See also: p9915 (DRIVE-CLiQ data transfer error, shutdown threshold, master)
<b>F35896</b>	<b>CU DRIVE-CLiQ: Inconsistent component characteristics</b>
<b>Reaction:</b>	A_INFEED: OFF2 (NONE, OFF1) SERVO: OFF2 (DCBRAKE, NONE, OFF1, OFF3, STOP1, STOP2) VECTOR: OFF2 (DCBRAKE, NONE, OFF1, OFF3, STOP1, STOP2)
<b>Acknowledge:</b>	IMMEDIATELY
<b>Cause:</b>	The properties of the DRIVE-CLiQ component, specified by the fault value, have changed in an incompatible fashion with respect to the properties when booted. One cause can be, e.g. that a DRIVE-CLiQ cable or DRIVE-CLiQ component has been replaced. Fault value (r0949, decimal): Component ID.
<b>Remedy:</b>	- when replacing cables, only use cables with the same length as the original cables. - when replacing components, use the same components and firmware releases. - carry-out a POWER ON.
<b>F35897</b>	<b>DRIVE-CLiQ: No communication to component</b>
<b>Reaction:</b>	A_INFEED: OFF2 (NONE, OFF1) SERVO: OFF2 (DCBRAKE, ENCODER, NONE, OFF1, OFF3, STOP1, STOP2) VECTOR: OFF2 (DCBRAKE, ENCODER, NONE, OFF1, OFF3, STOP1, STOP2)
<b>Acknowledge:</b>	IMMEDIATELY (POWER ON)
<b>Cause:</b>	Communications with the DRIVE-CLiQ component specified by the fault value is not possible. One cause can be, e.g. that a DRIVE-CLiQ cable has been withdrawn. Fault value (r0949, decimal): Component ID.
<b>Remedy:</b>	- check the DRIVE-CLiQ connections. - carry-out a POWER ON.
<b>F35899 (N, A)</b>	<b>TM: Unknown fault</b>
<b>Reaction:</b>	A_INFEED: NONE (OFF1, OFF2) SERVO: NONE (DCBRAKE, OFF1, OFF2, OFF3, STOP1, STOP2) VECTOR: NONE (DCBRAKE, OFF1, OFF2, OFF3, STOP1, STOP2)
<b>Acknowledge:</b>	IMMEDIATELY (POWER ON)



**Cause:** A fault has occurred on the Terminal Module that cannot be interpreted by the Control Unit firmware. This can occur if the firmware on the Terminal Module is more recent than the firmware on the Control Unit. Fault value (r0949, decimal): Fault number. If required, the significance of this new fault can be read about in a more recent description of the Control Unit.

**Remedy:** - replace the firmware on the Terminal Module by an older firmware version (r0158).  
- upgrade the firmware on the Control Unit (r0018).

Reaction upon N: NONE

Acknowledge upon N: NONE

Reaction upon A: NONE

Acknowledge upon A: NONE

**A35903 (F, N) TM: Error I2C bus**

**Reaction:** NONE

**Acknowledge:** NONE

**Cause:** An error has occurred while accessing the internal I2C bus of the Terminal Module.

**Remedy:** Replace the Terminal Module.

Reaction upon F: NONE

Acknowledge upon F: IMMEDIATELY (POWER ON)

Reaction upon N: NONE

Acknowledge upon N: NONE

**A35904 (F, N) TM: EEPROM**

**Reaction:** NONE

**Acknowledge:** NONE

**Cause:** An error has occurred accessing the non-volatile memory on the Terminal Module.

**Remedy:** Replace the Terminal Module.

Reaction upon F: NONE

Acknowledge upon F: IMMEDIATELY (POWER ON)

Reaction upon N: NONE

Acknowledge upon N: NONE

**A35905 (F, N) TM: Parameter access**

**Reaction:** NONE

**Acknowledge:** NONE

**Cause:** The Control Unit attempted to write an illegal parameter value into the Terminal Module.

**Remedy:** - check whether the firmware version of the TM (r0158) matches the firmware version of Control Unit (r0018).  
- if required, replace the Terminal Module.

Note:

The firmware versions that match each other are in the readme.txt file on the CompactFlash card.

Reaction upon F: NONE

Acknowledge upon F: IMMEDIATELY (POWER ON)

Reaction upon N: NONE

Acknowledge upon N: NONE

---

**A35906 (F, N)    TM: 24 V power supply missing**

**Reaction:** NONE

**Acknowledge:** NONE

**Cause:** The 24 V power supply for the digital outputs is missing.  
Alarm value (r2124, interpret hexadecimal):  
01: TM17 24 V power supply for DI/DO 0 ... 7 missing.  
02: TM17 24 V power supply for DI/DO 8 ... 15 missing.  
04: TM15 24 V power supply for DI/DO 0 ... 7 (X520) missing.  
08: TM15 24 V power supply for DI/DO 8 ... 15 (X521) missing.  
10: TM15 24 V power supply for DI/DO 16 ... 23 (X522) missing.  
20: TM41 24 V power supply for DI/DO 0 ... 3 missing.

**Remedy:** Check the terminals for the power supply voltage (L1+, L2+, L3+, M).

Reaction upon F: NONE

Acknowledge upon F: IMMEDIATELY (POWER ON)

Reaction upon N: NONE

Acknowledge upon N: NONE

---

**A35907 (F, N)    TM: Hardware initialization error**

**Reaction:** NONE

**Acknowledge:** NONE

**Cause:** The Terminal Module was not successfully initialized.  
Alarm value (r2124, interpret hexadecimal):  
01: TM17 or TM41 - incorrect configuration request.  
02: TM17 or TM41 - programming not successful.  
04: TM17 or TM41 - invalid time stamp

**Remedy:** Carry-out a POWER ON.

Reaction upon F: NONE

Acknowledge upon F: IMMEDIATELY (POWER ON)

Reaction upon N: NONE

Acknowledge upon N: NONE

---

**A35910 (F, N)    TM: Module overtemperature**

**Reaction:** NONE

**Acknowledge:** NONE

**Cause:** The temperature in the module has exceeded the highest permissible limit.

**Remedy:** - reduce the ambient temperature.  
- replace the Terminal Module.

Reaction upon F: NONE

Acknowledge upon F: IMMEDIATELY (POWER ON)

Reaction upon N: NONE

Acknowledge upon N: NONE

---

---

<b>A35911 (F, N)</b>	<b>TM: PROFIBUS clock synchronous operation sign-of-life missing</b>
<b>Reaction:</b>	NONE
<b>Acknowledge:</b>	NONE
<b>Cause:</b>	The maximum permissible number of errors in the master sign-of-life (clock synchronous PROFIBUS) has been exceeded in cyclic operation. When the alarm is output, the module outputs are reset up to the next synchronization.
<b>Remedy:</b>	- check the physical bus configuration (terminating resistor, shielding, etc.). - check the interconnection of the master sign-of-life (r4201 via p0915). - check whether the master correctly sends the sign-of-life (e.g. set-up a trace with r4201.12 ... r4201.15 and trigger signal r4301.9). - check the bus and master for utilization level (e.g. bus cycle time Tdp was set too short).
Reaction upon F:	NONE
Acknowledge upon F:	IMMEDIATELY (POWER ON)
Reaction upon N:	NONE
Acknowledge upon N:	NONE

---

<b>A35920 (F, N)</b>	<b>TM: Temperature sensor fault</b>
<b>Reaction:</b>	NONE
<b>Acknowledge:</b>	NONE
<b>Cause:</b>	When evaluating the temperature sensor, an error occurred. Alarm value (r2124, decimal): 1: Wire breakage or sensor not connected (KTY: R > 1630 Ohm). 2: Measured resistance too low (PTC: R < 20 Ohm, KTY: R < 50 Ohm).
<b>Remedy:</b>	- check that the sensor is connected correctly. - replace sensor.
Reaction upon F:	NONE
Acknowledge upon F:	IMMEDIATELY (POWER ON)
Reaction upon N:	NONE
Acknowledge upon N:	NONE

---

<b>A35999 (F, N)</b>	<b>TM: Unknown alarm</b>
<b>Reaction:</b>	NONE
<b>Acknowledge:</b>	NONE
<b>Cause:</b>	An alarm has occurred on the Terminal Module that cannot be interpreted by the Control Unit firmware. This can occur if the firmware on the Terminal Module is more recent than the firmware on the Control Unit. Alarm value (r2124, decimal): Alarm number. If required, the significance of this new alarm can be read about in a more recent description of the Control Unit.
<b>Remedy:</b>	- replace the firmware on the Terminal Module by an older firmware version (r0158). - upgrade the firmware on the Control Unit (r0018).
Reaction upon F:	A_INFEED: NONE (OFF1, OFF2) SERVO: NONE (DCBRAKE, OFF1, OFF2, OFF3, STOP1, STOP2) VECTOR: NONE (DCBRAKE, OFF1, OFF2, OFF3, STOP1, STOP2)
Acknowledge upon F:	IMMEDIATELY (POWER ON)
Reaction upon N:	NONE
Acknowledge upon N:	NONE

<b>A36801 (F, N)</b>	<b>DMC DRIVE-CLiQ: Sign-of-life missing</b>
<b>Reaction:</b>	NONE
<b>Acknowledge:</b>	NONE
<b>Cause:</b>	A DRIVE-CLiQ communications error has occurred between the Control Unit and the DRIVE-CLiQ Hub Module Cabinet (DMC) involved. Alarm value (r2124, interpret hexadecimal): 0A: The sign-of-life bit in the receive telegram is not set.
<b>Remedy:</b>	- check the DRIVE-CLiQ connection. - replace the component involved. See also: p9916 (DRIVE-CLiQ data transfer error, shutdown threshold, slave)
Reaction upon F:	NONE
Acknowledge upon F:	IMMEDIATELY
Reaction upon N:	NONE
Acknowledge upon N:	NONE
<b>A36804 (F, N)</b>	<b>DMC: CRC</b>
<b>Reaction:</b>	NONE
<b>Acknowledge:</b>	NONE
<b>Cause:</b>	A checksum error has occurred when reading-out the program memory on the DRIVE-CLiQ Hub Module Cabinet (DMC). Fault value (r0949, interpret hexadecimal): Difference between the checksum at POWER ON and the actual checksum.
<b>Remedy:</b>	- check whether the permissible ambient temperature for the component is maintained. - replace the DRIVE-CLiQ Hub Module Cabinet (DMC).
Reaction upon F:	NONE
Acknowledge upon F:	IMMEDIATELY (POWER ON)
Reaction upon N:	NONE
Acknowledge upon N:	NONE
<b>A36805 (F, N)</b>	<b>DMC: EPROM checksum error</b>
<b>Reaction:</b>	NONE
<b>Acknowledge:</b>	NONE
<b>Cause:</b>	Internal parameter data is corrupted. Alarm value (r2124, interpret hexadecimal): 01: EEPROM access error. 02: Too many blocks in the EEPROM.
<b>Remedy:</b>	- check whether the permissible ambient temperature for the component is maintained. - replace the DRIVE-CLiQ Hub Module Cabinet (DMC).
Reaction upon F:	NONE
Acknowledge upon F:	IMMEDIATELY (POWER ON)
Reaction upon N:	NONE
Acknowledge upon N:	NONE

<b>F36820</b>	<b>DMC DRIVE-CLiQ: Telegram error</b>
<b>Reaction:</b>	NONE
<b>Acknowledge:</b>	IMMEDIATELY
<b>Cause:</b>	A DRIVE-CLiQ communications error has occurred between the Control Unit and the DRIVE-CLiQ Hub Module Cabinet (DMC) involved. Fault value (r0949, interpret hexadecimal): 01: CRC error. 02: Telegram is shorter than specified in the length byte or in the receive list. 03: Telegram is longer than specified in the length byte or in the receive list. 04: The length of the receive telegram does not match the receive list. 05: The type of the receive telegram does not match the receive list. 06: The address of the Terminal Module in the telegram and in the receive list do not match. 07: Terminal Module expects a SYNC telegram, but the receive telegram is not a SYNC telegram. 08: Terminal Module does not expect a SYNC telegram, but the receive telegram is a SYNC telegram. 09: The error bit in the receive telegram is set. 10: The receive telegram is too early.
<b>Remedy:</b>	- carry-out a POWER ON. - check the electrical cabinet design and cable routing for EMC compliance. - check the DRIVE-CLiQ wiring (interrupted cable, contacts, ...). See also: p9916 (DRIVE-CLiQ data transfer error, shutdown threshold, slave)
<b>F36835</b>	<b>DMC DRIVE-CLiQ: Cyclic data transfer error</b>
<b>Reaction:</b>	NONE
<b>Acknowledge:</b>	IMMEDIATELY
<b>Cause:</b>	A DRIVE-CLiQ communications error has occurred between the Control Unit and the DRIVE-CLiQ Hub Module Cabinet (DMC) involved. The nodes do not send and receive in synchronism. Fault value (r0949, interpret hexadecimal): 21: The cyclic telegram has not been received. 22: Timeout in the telegram receive list. 40: Timeout in the telegram send list.
<b>Remedy:</b>	- carry-out a POWER ON. - replace the component involved. See also: p9916 (DRIVE-CLiQ data transfer error, shutdown threshold, slave)
<b>F36836</b>	<b>DMC DRIVE-CLiQ: Send error for DRIVE-CLiQ data</b>
<b>Reaction:</b>	NONE
<b>Acknowledge:</b>	IMMEDIATELY
<b>Cause:</b>	A DRIVE-CLiQ communications error has occurred between the Control Unit and the DRIVE-CLiQ Hub Module Cabinet (DMC) involved. Data were not able to be sent. Fault value (r0949, interpret hexadecimal): 41: Telegram type does not match send list.
<b>Remedy:</b>	Carry-out a POWER ON.
<b>F36837</b>	<b>DMC DRIVE-CLiQ: Component fault</b>
<b>Reaction:</b>	NONE
<b>Acknowledge:</b>	IMMEDIATELY
<b>Cause:</b>	Fault detected on the DRIVE-CLiQ component involved. Faulty hardware cannot be excluded. Fault value (r0949, interpret hexadecimal): 20: Error in the telegram header. 23: Receive error: The telegram buffer memory contains an error. 42: Send error: The telegram buffer memory contains an error. 43: Send error: The telegram buffer memory contains an error.
<b>Remedy:</b>	- check the DRIVE-CLiQ wiring (interrupted cable, contacts, ...). - check the electrical cabinet design and cable routing for EMC compliance. - if required, use another DRIVE-CLiQ socket (p9904). - replace the component involved.

<b>F36845</b>	<b>DMC DRIVE-CLiQ: Cyclic data transfer error</b>
<b>Reaction:</b>	NONE
<b>Acknowledge:</b>	IMMEDIATELY
<b>Cause:</b>	A DRIVE-CLiQ communications error has occurred between the Control Unit and the DRIVE-CLiQ Hub Module Cabinet (DMC) involved. Fault value (r0949, interpret hexadecimal): 0B: Synchronization error during alternating cyclic data transfer.
<b>Remedy:</b>	Carry-out a POWER ON. See also: p9916 (DRIVE-CLiQ data transfer error, shutdown threshold, slave)
<b>F36851</b>	<b>CU DRIVE-CLiQ: Sign-of-life missing</b>
<b>Reaction:</b>	NONE
<b>Acknowledge:</b>	IMMEDIATELY
<b>Cause:</b>	A DRIVE-CLiQ communications error has occurred between the Control Unit and the DRIVE-CLiQ Hub Module Cabinet (DMC) involved. The DRIVE-CLiQ component did not set the sign of life to the Control Unit. Fault value (r0949, interpret hexadecimal): 0A: The sign-of-life bit in the receive telegram is not set.
<b>Remedy:</b>	Upgrade the firmware of the component involved.
<b>F36860</b>	<b>CU DRIVE-CLiQ: Telegram error</b>
<b>Reaction:</b>	NONE
<b>Acknowledge:</b>	IMMEDIATELY
<b>Cause:</b>	A DRIVE-CLiQ communications error has occurred between the Control Unit and the DRIVE-CLiQ Hub Module Cabinet (DMC) involved. Fault value (r0949, interpret hexadecimal): 11: CRC error and the receive telegram is too early. 01: CRC error. 12: The telegram is shorter than that specified in the length byte or in the receive list and the receive telegram is too early. 02: Telegram is shorter than specified in the length byte or in the receive list. 13: The telegram is longer than that specified in the length byte or in the receive list and the receive telegram is too early. 03: Telegram is longer than specified in the length byte or in the receive list. 14: The length of the receive telegram does not match the receive list and the receive telegram is too early. 04: The length of the receive telegram does not match the receive list. 15: The type of the receive telegram does not match the receive list and the receive telegram is too early. 05: The type of the receive telegram does not match the receive list. 16: The address of the Terminal Module in the telegram and in the receive list does not match and the receive telegram is too early. 06: The address of the Terminal Module in the telegram and in the receive list do not match. 19: The error bit in the receive telegram is set and the receive telegram is too early. 09: The error bit in the receive telegram is set. 10: The receive telegram is too early.
<b>Remedy:</b>	- carry-out a POWER ON. - check the electrical cabinet design and cable routing for EMC compliance. - check the DRIVE-CLiQ wiring (interrupted cable, contacts, ...).
<b>F36885</b>	<b>CU DRIVE-CLiQ: Cyclic data transfer error</b>
<b>Reaction:</b>	NONE
<b>Acknowledge:</b>	IMMEDIATELY
<b>Cause:</b>	A DRIVE-CLiQ communications error has occurred between the Control Unit and the DRIVE-CLiQ Hub Module Cabinet (DMC) involved. The nodes do not send and receive in synchronism. Fault value (r0949, interpret hexadecimal): 1A: Sign-of-life bit in the receive telegram not set and the receive telegram is too early. 21: The cyclic telegram has not been received. 22: Timeout in the telegram receive list. 40: Timeout in the telegram send list. 62: Error at the transition to cyclic operation.

**Remedy:**

- check the power supply voltage of the component involved.
- carry-out a POWER ON.
- replace the component involved.

**F36886 CU DRIVE-CLiQ: Error when sending DRIVE-CLiQ data**

**Reaction:** NONE  
**Acknowledge:** IMMEDIATELY  
**Cause:** A DRIVE-CLiQ communications error has occurred between the Control Unit and the DRIVE-CLiQ Hub Module Cabinet (DMC) involved. Data were not able to be sent.  
 Fault value (r0949, interpret hexadecimal):  
 41: Telegram type does not match send list.  
**Remedy:** Carry-out a POWER ON.

**F36887 CU DRIVE-CLiQ: Component fault**

**Reaction:** NONE  
**Acknowledge:** IMMEDIATELY  
**Cause:** Fault detected on the DRIVE-CLiQ component involved. Faulty hardware cannot be excluded.  
 Fault value (r0949, interpret hexadecimal):  
 20: Error in the telegram header.  
 23: Receive error: The telegram buffer memory contains an error.  
 42: Send error: The telegram buffer memory contains an error.  
 43: Send error: The telegram buffer memory contains an error.  
 60: Response received too late during runtime measurement.  
 61: Time taken to exchange characteristic data too long.  
**Remedy:**

- check the DRIVE-CLiQ wiring (interrupted cable, contacts, ...).
- check the electrical cabinet design and cable routing for EMC compliance.
- if required, use another DRIVE-CLiQ socket (p9904).
- replace the component involved.

**F36895 CU DRIVE-CLiQ: Cyclic data transfer error**

**Reaction:** NONE  
**Acknowledge:** IMMEDIATELY  
**Cause:** A DRIVE-CLiQ communications error has occurred between the Control Unit and the DRIVE-CLiQ Hub Module Cabinet (DMC) involved.  
 Fault value (r0949, interpret hexadecimal):  
 0B: Synchronization error during alternating cyclic data transfer.  
**Remedy:** Carry-out a POWER ON.  
 See also: p9915 (DRIVE-CLiQ data transfer error, shutdown threshold, master)

**F36896 CU DRIVE-CLiQ: Inconsistent component characteristics**

**Reaction:** NONE  
**Acknowledge:** IMMEDIATELY  
**Cause:** The properties of the DRIVE-CLiQ component, specified by the fault value, have changed in an incompatible fashion with respect to the properties when booted. One cause can be, e.g. that a DRIVE-CLiQ cable or DRIVE-CLiQ component has been replaced.  
 Fault value (r0949, decimal):  
 Component ID.  
**Remedy:**

- when replacing cables, only use cables with the same length as the original cables.
- when replacing components, use the same components and firmware releases.
- carry-out a POWER ON.

**F40000 Fault on the drive object at the DRIVE-CLiQ socket X100**

**Reaction:** NONE  
**Acknowledge:** IMMEDIATELY  
**Cause:** A fault has occurred at the drive object at the DRIVE-CLiQ socket X100.  
 Fault value (r0949, decimal):  
 First fault that has occurred for this drive object.  
**Remedy:** Evaluate the fault buffer of the specified object.

---

**F40001      Fault on the drive object at the DRIVE-CLiQ socket X101**

**Reaction:** NONE  
**Acknowledge:** IMMEDIATELY  
**Cause:** A fault has occurred at the drive object at the DRIVE-CLiQ socket X101.  
 Fault value (r0949, decimal):  
 First fault that has occurred for this drive object.  
**Remedy:** Evaluate the fault buffer of the specified object.

---

**F40002      Fault on the drive object at the DRIVE-CLiQ socket X102**

**Reaction:** NONE  
**Acknowledge:** IMMEDIATELY  
**Cause:** A fault has occurred at the drive object at the DRIVE-CLiQ socket X102.  
 Fault value (r0949, decimal):  
 First fault that has occurred for this drive object.  
**Remedy:** Evaluate the fault buffer of the specified object.

---

**F40003      Fault on the drive object at the DRIVE-CLiQ socket X103**

**Reaction:** NONE  
**Acknowledge:** IMMEDIATELY  
**Cause:** A fault has occurred at the drive object at the DRIVE-CLiQ socket X103.  
 Fault value (r0949, decimal):  
 First fault that has occurred for this drive object.  
**Remedy:** Evaluate the fault buffer of the specified object.

---

**F40004      Fault on the drive object at the DRIVE-CLiQ socket X104**

**Reaction:** NONE  
**Acknowledge:** IMMEDIATELY  
**Cause:** A fault has occurred at the drive object at the DRIVE-CLiQ socket X104.  
 Fault value (r0949, decimal):  
 First fault that has occurred for this drive object.  
**Remedy:** Evaluate the fault buffer of the specified object.

---

**F40005      Fault on the drive object at the DRIVE-CLiQ socket X105**

**Reaction:** NONE  
**Acknowledge:** IMMEDIATELY  
**Cause:** A fault has occurred at the drive object at the DRIVE-CLiQ socket X105.  
 Fault value (r0949, decimal):  
 First fault that has occurred for this drive object.  
**Remedy:** Evaluate the fault buffer of the specified object.

---

**A40100      Alarm on the drive object at the DRIVE-CLiQ socket X100**

**Reaction:** NONE  
**Acknowledge:** NONE  
**Cause:** An alarm has occurred at the drive object at the DRIVE-CLiQ socket X100.  
 Alarm value (r2124, decimal):  
 First alarm that has occurred for this drive object.  
**Remedy:** Evaluate the alarm buffer of the specified object.

---

**A40101      Alarm on the drive object at the DRIVE-CLiQ socket X101**

**Reaction:** NONE  
**Acknowledge:** NONE  
**Cause:** An alarm has occurred at the drive object at the DRIVE-CLiQ socket X101.  
 Alarm value (r2124, decimal):  
 First alarm that has occurred for this drive object.  
**Remedy:** Evaluate the alarm buffer of the specified object.



<b>A40102</b>	<b>Alarm on the drive object at the DRIVE-CLiQ socket X102</b>
<b>Reaction:</b>	NONE
<b>Acknowledge:</b>	NONE
<b>Cause:</b>	An alarm has occurred at the drive object at the DRIVE-CLiQ socket X102. Alarm value (r2124, decimal): First alarm that has occurred for this drive object.
<b>Remedy:</b>	Evaluate the alarm buffer of the specified object.
<b>A40103</b>	<b>Alarm on the drive object at the DRIVE-CLiQ socket X103</b>
<b>Reaction:</b>	NONE
<b>Acknowledge:</b>	NONE
<b>Cause:</b>	An alarm has occurred at the drive object at the DRIVE-CLiQ socket X103. Alarm value (r2124, decimal): First alarm that has occurred for this drive object.
<b>Remedy:</b>	Evaluate the alarm buffer of the specified object.
<b>A40104</b>	<b>Alarm on the drive object at the DRIVE-CLiQ socket X104</b>
<b>Reaction:</b>	NONE
<b>Acknowledge:</b>	NONE
<b>Cause:</b>	An alarm has occurred at the drive object at the DRIVE-CLiQ socket X104. Alarm value (r2124, decimal): First alarm that has occurred for this drive object.
<b>Remedy:</b>	Evaluate the alarm buffer of the specified object.
<b>A40105</b>	<b>Alarm on the drive object at the DRIVE-CLiQ socket X105</b>
<b>Reaction:</b>	NONE
<b>Acknowledge:</b>	NONE
<b>Cause:</b>	An alarm has occurred at the drive object at the DRIVE-CLiQ socket X105. Alarm value (r2124, decimal): First alarm that has occurred for this drive object.
<b>Remedy:</b>	Evaluate the alarm buffer of the specified object.
<b>F40799</b>	<b>CU-Link: Configured transfer end time exceeded</b>
<b>Reaction:</b>	NONE
<b>Acknowledge:</b>	IMMEDIATELY
<b>Cause:</b>	The configured transfer end time when transferring the cyclic actual values was exceeded.
<b>Remedy:</b>	- carry-out a POWER ON (power off/on) for all components. - contact the Hotline.
<b>F40801</b>	<b>CX32 DRIVE-CLiQ: Sign-of-life missing</b>
<b>Reaction:</b>	OFF2
<b>Acknowledge:</b>	IMMEDIATELY
<b>Cause:</b>	A DRIVE-CLiQ communications error has occurred between the Control Unit and the controller extension involved. The nodes do not send and receive in synchronism. Fault value (r0949, interpret hexadecimal): 0A: The sign-of-life bit in the receive telegram is not set.
<b>Remedy:</b>	- carry-out a POWER ON. - replace the component involved. See also: p9916 (DRIVE-CLiQ data transfer error, shutdown threshold, slave)

<b>F40820</b>	<b>CX32 DRIVE-CLiQ: Telegram error</b>
<b>Reaction:</b>	OFF2
<b>Acknowledge:</b>	IMMEDIATELY
<b>Cause:</b>	A DRIVE-CLiQ communications error has occurred between the Control Unit and the controller extension involved. Fault value (r0949, interpret hexadecimal): 01: CRC error. 02: Telegram is shorter than specified in the length byte or in the receive list. 03: Telegram is longer than specified in the length byte or in the receive list. 04: The length of the receive telegram does not match the receive list. 05: The type of the receive telegram does not match the receive list. 06: The address of the controller extension in the telegram and in the receive list do not match. 07: Controller extension expects a SYNC telegram, but the receive telegram is not a SYNC telegram. 08: Controller extension does not expect a SYNC telegram, but the receive telegram is a SYNC telegram. 09: The error bit in the receive telegram is set. 10: The receive telegram is too early.
<b>Remedy:</b>	- carry-out a POWER ON. - check the electrical cabinet design and cable routing for EMC compliance. - check the DRIVE-CLiQ wiring (interrupted cable, contacts, ...). See also: p9916 (DRIVE-CLiQ data transfer error, shutdown threshold, slave)
<b>F40835</b>	<b>CX32 DRIVE-CLiQ: Cyclic data transfer error</b>
<b>Reaction:</b>	OFF2
<b>Acknowledge:</b>	IMMEDIATELY
<b>Cause:</b>	A DRIVE-CLiQ communications error has occurred between the Control Unit and the controller extension involved. The nodes do not send and receive in synchronism. Fault value (r0949, interpret hexadecimal): 21: The cyclic telegram has not been received. 22: Timeout in the telegram receive list. 40: Timeout in the telegram send list.
<b>Remedy:</b>	- carry-out a POWER ON. - replace the component involved. See also: p9916 (DRIVE-CLiQ data transfer error, shutdown threshold, slave)
<b>F40836</b>	<b>CX32 DRIVE-CLiQ: Send error for DRIVE-CLiQ data</b>
<b>Reaction:</b>	OFF2
<b>Acknowledge:</b>	IMMEDIATELY
<b>Cause:</b>	A DRIVE-CLiQ communications error has occurred between the Control Unit and the controller extension involved. Data were not able to be sent. Fault value (r0949, interpret hexadecimal): 41: Telegram type does not match send list.
<b>Remedy:</b>	Carry-out a POWER ON.
<b>F40837</b>	<b>CX32 DRIVE-CLiQ: Component fault</b>
<b>Reaction:</b>	OFF2
<b>Acknowledge:</b>	IMMEDIATELY
<b>Cause:</b>	Fault detected on the DRIVE-CLiQ component involved. Faulty hardware cannot be excluded. Fault value (r0949, interpret hexadecimal): 20: Error in the telegram header. 23: Receive error: The telegram buffer memory contains an error. 42: Send error: The telegram buffer memory contains an error. 43: Send error: The telegram buffer memory contains an error.
<b>Remedy:</b>	- check the DRIVE-CLiQ wiring (interrupted cable, contacts, ...). - check the electrical cabinet design and cable routing for EMC compliance. - if required, use another DRIVE-CLiQ socket (p9904). - replace the component involved.

<b>F40845</b>	<b>CX32 DRIVE-CLiQ: Cyclic data transfer error</b>
<b>Reaction:</b>	OFF2
<b>Acknowledge:</b>	IMMEDIATELY
<b>Cause:</b>	A DRIVE-CLiQ communications error has occurred between the Control Unit and the controller extension involved. Fault value (r0949, interpret hexadecimal): 0B: Synchronization error during alternating cyclic data transfer.
<b>Remedy:</b>	Carry-out a POWER ON. See also: p9916 (DRIVE-CLiQ data transfer error, shutdown threshold, slave)
<b>F40851</b>	<b>CU DRIVE-CLiQ: Sign-of-life missing</b>
<b>Reaction:</b>	OFF2
<b>Acknowledge:</b>	IMMEDIATELY
<b>Cause:</b>	A DRIVE-CLiQ communications error has occurred between the Control Unit and the controller extension involved. The DRIVE-CLiQ component did not set the sign of life to the Control Unit. Fault value (r0949, interpret hexadecimal): 0A: The sign-of-life bit in the receive telegram is not set.
<b>Remedy:</b>	Upgrade the firmware of the component involved.
<b>F40860</b>	<b>CU DRIVE-CLiQ: Telegram error</b>
<b>Reaction:</b>	OFF2
<b>Acknowledge:</b>	IMMEDIATELY
<b>Cause:</b>	A DRIVE-CLiQ communications error has occurred between the Control Unit and the controller extension involved. Fault value (r0949, interpret hexadecimal): 11: CRC error and the receive telegram is too early. 01: CRC error. 12: The telegram is shorter than that specified in the length byte or in the receive list and the receive telegram is too early. 02: Telegram is shorter than specified in the length byte or in the receive list. 13: The telegram is longer than that specified in the length byte or in the receive list and the receive telegram is too early. 03: Telegram is longer than specified in the length byte or in the receive list. 14: The length of the receive telegram does not match the receive list and the receive telegram is too early. 04: The length of the receive telegram does not match the receive list. 15: The type of the receive telegram does not match the receive list and the receive telegram is too early. 05: The type of the receive telegram does not match the receive list. 16: The address of the controller extension in the telegram and in the receive list does not match and the receive telegram is too early. 06: The address of the controller extension in the telegram and in the receive list do not match. 19: The error bit in the receive telegram is set and the receive telegram is too early. 09: The error bit in the receive telegram is set. 10: The receive telegram is too early.
<b>Remedy:</b>	- carry-out a POWER ON. - check the electrical cabinet design and cable routing for EMC compliance. - check the DRIVE-CLiQ wiring (interrupted cable, contacts, ...). See also: p9915 (DRIVE-CLiQ data transfer error, shutdown threshold, master)
<b>F40885</b>	<b>CU DRIVE-CLiQ: Cyclic data transfer error</b>
<b>Reaction:</b>	OFF2
<b>Acknowledge:</b>	IMMEDIATELY
<b>Cause:</b>	A DRIVE-CLiQ communications error has occurred between the Control Unit and the controller extension involved. The nodes do not send and receive in synchronism. Fault value (r0949, interpret hexadecimal): 0A: The sign-of-life bit in the receive telegram is not set. 1A: Sign-of-life bit in the receive telegram not set and the receive telegram is too early. 21: The cyclic telegram has not been received. 22: Timeout in the telegram receive list. 40: Timeout in the telegram send list. 62: Error at the transition to cyclic operation.

**Remedy:**

- check the power supply voltage of the component involved.
- carry-out a POWER ON.
- replace the component involved.

See also: p9915 (DRIVE-CLiQ data transfer error, shutdown threshold, master)

---

**F40886 CU DRIVE-CLiQ: Error when sending DRIVE-CLiQ data**

**Reaction:** OFF2  
**Acknowledge:** IMMEDIATELY  
**Cause:** A DRIVE-CLiQ communications error has occurred between the Control Unit and the controller extension involved.  
 Data were not able to be sent.  
 Fault value (r0949, interpret hexadecimal):  
 41: Telegram type does not match send list.  
**Remedy:** Carry-out a POWER ON.

---

**F40887 CU DRIVE-CLiQ: Component fault**

**Reaction:** OFF2  
**Acknowledge:** IMMEDIATELY  
**Cause:** Fault detected on the DRIVE-CLiQ component involved. Faulty hardware cannot be excluded.  
 Fault value (r0949, interpret hexadecimal):  
 20: Error in the telegram header.  
 23: Receive error: The telegram buffer memory contains an error.  
 42: Send error: The telegram buffer memory contains an error.  
 43: Send error: The telegram buffer memory contains an error.  
 60: Response received too late during runtime measurement.  
 61: Time taken to exchange characteristic data too long.  
**Remedy:**

- check the DRIVE-CLiQ wiring (interrupted cable, contacts, ...).
- check the electrical cabinet design and cable routing for EMC compliance.
- if required, use another DRIVE-CLiQ socket (p9904).
- replace the component involved.

---

**F40895 CU DRIVE-CLiQ: Cyclic data transfer error**

**Reaction:** OFF2  
**Acknowledge:** IMMEDIATELY  
**Cause:** A DRIVE-CLiQ communications error has occurred between the Control Unit and the controller extension involved.  
 Fault value (r0949, interpret hexadecimal):  
 0B: Synchronization error during alternating cyclic data transfer.  
**Remedy:** Carry-out a POWER ON.  
 See also: p9915 (DRIVE-CLiQ data transfer error, shutdown threshold, master)

---

**F49150 Cooling system: Fault occurred**

**Reaction:** OFF2  
**Acknowledge:** IMMEDIATELY  
**Cause:** The cooling system signals a general fault.  
**Remedy:**

- check the wiring between the cooling system and the input terminal (Terminal Module).
- check the external Control Unit for the cooling system.

See also: p0266 (Cooling system, signal source feedback signals)

---

**F49151 Cooling system: Conductivity has exceeded the fault threshold**

**Reaction:** OFF2  
**Acknowledge:** IMMEDIATELY  
**Cause:** The conductivity of the cooling water has exceeded the selected fault threshold (p0269[2]).  
 See also: p0261 (Cooling system, starting time 2), p0262 (Cooling system, fault conductivity delay time), p0266 (Cooling system, signal source feedback signals)  
**Remedy:** Check the device to de-ionize the cooling water.

<b>F49152</b>	<b>Cooling system: ON command, feedback signal missing</b>
<b>Reaction:</b>	OFF2
<b>Acknowledge:</b>	IMMEDIATELY
<b>Cause:</b>	The feedback signal of the ON command of the cooling system is missing. - after the ON command, the feedback signal has not been received within the selected starting time (p0260). - the feedback signal has failed in operation. See also: p0260 (Cooling system, starting time 1), r0267 (Cooling system status word display)
<b>Remedy:</b>	- check the wiring between the cooling system and the input terminal (Terminal Module). - check the external Control Unit for the cooling system.
<b>F49153</b>	<b>Cooling system: Water flow too low</b>
<b>Reaction:</b>	OFF2
<b>Acknowledge:</b>	IMMEDIATELY
<b>Cause:</b>	The drive converter cooling system signals that the water flow is too low. - after the ON command, the feedback signal has not been received within the selected starting time (p0260). - in operation, the feedback signal has failed for longer than the permitted failure time (p0263). See also: p0260 (Cooling system, starting time 1), p0263 (Cooling system fault water flow, delay time), r0267 (Cooling system status word display)
<b>Remedy:</b>	- check the wiring between the cooling system and the input terminal (Terminal Module). - check the external Control Unit for the cooling system.
<b>F49154</b>	<b>Cooling system: Water has leaked</b>
<b>Reaction:</b>	OFF2
<b>Acknowledge:</b>	IMMEDIATELY
<b>Cause:</b>	The leakage water monitoring function has responded. See also: r0267 (Cooling system status word display)
<b>Remedy:</b>	- check the cooling system for leaks in the cooling circuit. - check the wiring of the input terminal (Terminal Module) used to monitor the leakage water.
<b>F49155</b>	<b>Cooling system: Power Stack Adapter, firmware version too old</b>
<b>Reaction:</b>	OFF2
<b>Acknowledge:</b>	POWER ON
<b>Cause:</b>	The firmware version in the Power Stack Adapter (PSA) is too old and does not support the water cooling.
<b>Remedy:</b>	Upgrade the firmware version.
<b>F49156</b>	<b>Cooling system: Cooling water temperature has exceeded the fault threshold</b>
<b>Reaction:</b>	OFF2
<b>Acknowledge:</b>	IMMEDIATELY
<b>Cause:</b>	The cooling water intake temperature has exceeded the permanently set fault threshold.
<b>Remedy:</b>	Check the cooling system and the ambient conditions.
<b>A49170</b>	<b>Cooling system: Alarm has occurred</b>
<b>Reaction:</b>	NONE
<b>Acknowledge:</b>	NONE
<b>Cause:</b>	The cooling system signals a general alarm.
<b>Remedy:</b>	- check the wiring between the cooling system and the input terminal (Terminal Module). - check the external Control Unit for the cooling system.
<b>A49171</b>	<b>Cooling system: Conductivity has exceeded the alarm threshold</b>
<b>Reaction:</b>	NONE
<b>Acknowledge:</b>	NONE
<b>Cause:</b>	The conductivity of the cooling water has exceeded the selected alarm threshold (p0269[1]). See also: p0261 (Cooling system, starting time 2), p0262 (Cooling system, fault conductivity delay time), p0266 (Cooling system, signal source feedback signals)
<b>Remedy:</b>	Check the device to de-ionize the cooling water.

<b>A49172</b>	<b>Cooling system: Conductivity actual value is not valid</b>
<b>Reaction:</b>	NONE
<b>Acknowledge:</b>	NONE
<b>Cause:</b>	When monitoring the conductivity of the cooling water, there is a fault in the wiring or in the sensor.
<b>Remedy:</b>	- check the wiring between the cooling system and the Power Stack Adapter (PSA). - check the function of the sensor to measure the conductivity.
<b>A49173</b>	<b>Cooling system: Cooling water temperature has exceeded the alarm threshold</b>
<b>Reaction:</b>	NONE
<b>Acknowledge:</b>	NONE
<b>Cause:</b>	The cooling water intake temperature has exceeded the permanently set alarm threshold.
<b>Remedy:</b>	Check the cooling system and the ambient conditions.
<b>F49200</b>	<b>Excitation group signal fault</b>
<b>Reaction:</b>	OFF2
<b>Acknowledge:</b>	IMMEDIATELY
<b>Cause:</b>	The excitation sequence control signals a fault. Fault value (r0949, hexadecimal): Bit 0: When powered-down or when powering-down the excitation, the signal "excitation ready to power-up feedback signal" was not received within the monitoring time. Bit 1: After an ON command, the signal "excitation ready feedback signal" was not received within the monitoring time. Bit 2: After the pulses were enabled, the signal "excitation operational feedback signal" was not received within the monitoring time. Bit 3: The "excitation group signal fault" signal is present.
<b>Remedy:</b>	- check the excitation. - check commands, feedback signals and BICO interconnections.
<b>A49201 (F)</b>	<b>Excitation, group signal alarm</b>
<b>Reaction:</b>	NONE
<b>Acknowledge:</b>	NONE
<b>Cause:</b>	The "excitation group signal alarm" signal is present.
<b>Remedy:</b>	Check the excitation equipment.
<b>Reaction upon F:</b>	NONE
<b>Acknowledge upon F:</b>	IMMEDIATELY